

# Sommario - Summary

Moduli LED professionali  
Professional LED modules Pag. 615

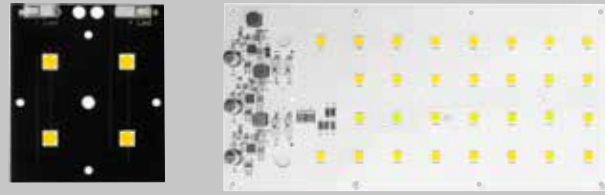

Lampade a LED - Lampade incandescenti  
LED Lamps - Incandescent lamps Pag. 616



Lampade professionali a LED  
Professional LED Lamps Pag. 623



Trafo per Halo-LED TBT 12Vac - Trafo Varialuce Halo-LED TBT 12Vac  
Halo-LED Trafo TBT 12 Vac - Dimmer touch Halo-LED Trafo TBT 12 Vac Pag. 626



Alimentatori LED  
LED drivers DALI 2 PUSH 1-10Vdc TRIAC Pag. 628



Kit di emergenza per LED (Inverter)  
LED emergency kit (Inverter) Pag. 638



Alimentatori LED e dimmer per progetti speciali  
LED driver and dimmer for special projects Pag. 656



# Sommario - Summary

LED driver - Controller RGB per Strisce LED 12V - 24V - 48V - Dimmer DALI Pag. 663



Varialuce per lampade LED  
Dimmer for LED bulbs HALO OK LED OK UL LISTED ENEC Pag. 673



Varialuce serie componibile lampade LED dimmerabili moduli LED Acrich  
Built in dimmer for dimmable LED bulbs and LED modules Acrich Pag. 689



Rilevatori di presenza e movimento  
Sensor solution provider DALI 1-10Vdc Pag. 692



Sistemi per edifici civili  
System for civil buildings Pag. 703



Condensatori e reattori per lampade a scarica  
Capacitors and ballast for discharge lamps Pag. 707



Trasformatori elettronici per bassissima tensione  
Electronic transformers for low voltage 12V Pag. 709



Portalampana in Bachelite, interruttori e cablaggi  
Bakelite lampholders, switches and cordset Pag. 710



# Moduli LED professionali - *Professional LED Modules*

## Dissipazione e assemblaggio

Per garantire i dati di luminosità e durata indicati può essere necessaria una dissipazione del modulo LED.

Verificare che la Tc del modulo LED non superi i valori massimi indicati nella tabella.

Si consiglia l'utilizzo di tutti i fori previsti per il fissaggio del modulo LED o l'utilizzo di pasta o adesivi termococonduttivi. Per non danneggiare i moduli LED utilizzare soltanto viti a testa arrotondata e rondelle plastiche piatte.

Se i moduli LED sono collegati in parallelo e un modulo si danneggia, tutta la corrente che passa nell'altro modulo LED aumenta. Questo potrebbe ridurre l'aspettativa di vita (life time) del modulo LED.

## Uso e pulizia

Non procurare shock ai moduli LED e conservarli in luogo non polveroso. Evitare il contatto con qualsiasi tipo di fluido, come olio e solventi organici. Si raccomanda l'uso di IPA (alcool isopropilico) quale solvente per la pulizia dei moduli LED. Prima di procedere con la pulizia, dovrebbe essere effettuato un pre-test per accertare potenziali danni al modulo LED.

## Lifetime

Il valore di luminosità di un modulo LED in base a 60.000/80.000 ore di funzionamento è indicato dalla lettera "L". La lettera "B" indica invece il numero dei LED che rispetteranno il valore L dopo 60.000 ore di funzionamento. I moduli LED RELCO sono garantiti L80B20, che significa che l'80% dei LED avrà una resa pari o superiore all'80% dopo 60.000 ore di utilizzo.

## Dissipation, assembly

*A dissipation of the LED module might be required to guarantee the stated datas of brightness and lifetime. Please verify that the modules Tc does not exceed the maximum values as indicated in the table. It is recommended the use of all the holes for the fixing of the LED module or the use of thermoconductive pastes or adhesives. To avoid any damages to the LED module please use only rounded head screws and an additional plastic flat washer. If the LED modules are wired in parallel and a module fails, all the current flowing through the other LED module increases. This may reduce the lifetime of the LED module.*

## Handling and Cleaning

*Don't give any shock to the LED modules nor store them in a dusty place. Avoid any contacts with any kind of fluid such as oil or organic solvents. It is recommended the use of IPA (isopropyl alcohol) as solvent to clean the LED modules. Before cleaning, a pre-test should be done to verify any possible damages to the LED module.*

## Lifetime

*The brightness value of a LED module according to 60.000/80.000 working hours is indicated by letter L. Letter B indicates the number of LEDs that keep the L value also after 60.000 working hours. TCI LED modules are guaranteed L80B20. In other words the 80% of the LEDs will have 80% or higher rendering after 60.000 working hours.*

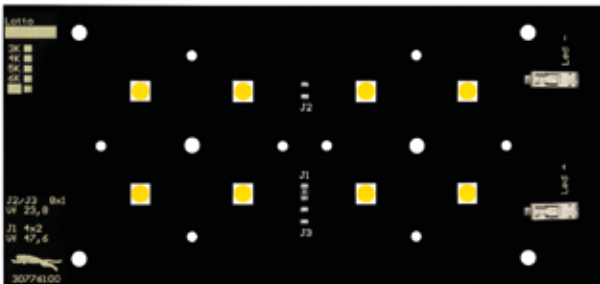
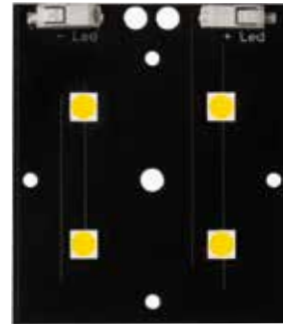

**A richiesta per quantità modulo LED custom - *On demand for quantity custom LED module***

## LAMPADE LED - LED LAMPS

### CONFORMI A:

- **Direttiva 2009/125/CE**  
(Direttiva Ecodesign)
- **Regolamento (UE) 2021/341**  
che garantiscono la corretta  
efficienza energetica  
e la durata

### COMPLY WITH:

- **Directive 2009/125 / EC**  
(Ecodesign Directive)
- **Regulation (EU) 2021/341**  
which guarantee the correct  
energy efficiency and durability

## REGOLAZIONE LAMPADE - LAMP DIMMING



Per una regolazione più sicura di lampade LED dimmerabili si consiglia l'uso dei dimmer Relco specifici per lampade LED  
For a better regulation of the LED bulbs we recommend the use of the dimmer Relco for LED bulbs



LT 2 UN  
Pag. 639

Regolatori da incasso per lampade LED dimmerabili  
Built in dimmer for dimmable LED bulbs  
Pag. 642

## Promo espositore - Expositor promotion

### LED

Codice espositore  
Expositor code  
**R00012.01**

Codice crowner luminoso  
Light crowner code  
**R00005.01**

Dimensioni - Dimensions  
**40x46x190cm**

Contiene **max 200** lampade  
Contains **max 200** lamps



## Sfera - Ball lamp

E14 - E27



- 1 -



- 2 -



- 3 -

Vetro - Glass

Plastica - Plastic



Astuccio con asola  
Pack with slot

Fig.	W	V			K	lm	Ra ≥	DIM			H mm	Ø mm	PCS		CBM m³		EAN 8009935	Code
- 1 -	4≈(40)	220-240	E14	360°	3000	500	80	SI	15.000	25.000	75	45	10	0,0035	ASA	101624	555242	
- 1 -	4≈(40)	220-240	E27	360°	3000	500	80	SI	15.000	25.000	75	45	10	0,0035	ASA	101693	555244	
- 1 -	4≈(40)	220-240	E14	360°	6500	500	80	SI	15.000	25.000	75	45	10	0,0035	ASA	101761	555243	
- 1 -	5≈(40)	220-240	E27	360°	6500	500	80	SI	15.000	25.000	75	45	10	0,0035	ASA	101839	555245	
- 2 -	4≈(40)	220-240	E14	360°	3000	500	80	NO	15.000	25.000	75	45	10	0,0035	ASA	007414	555277.0101	
- 2 -	4≈(40)	220-240	E14	360°	4000	470	80	NO	15.000	25.000	82	45	10	0,0017	ASA	0074201	555277.4K	
- 2 -	5≈(40)	220-240	E27	360°	3000	550	80	NO	15.000	25.000	75	45	10	0,0035	ASA	101174	555281.0101	
- 3 -	4≈(60)	220-240	E27	360°	6500	600	80	NO	15.000	25.000	75	45	10	0,0035	ASA	021434	555245.0101	

## Oliva - Candle

E14



- 1 -



- 2 -

Vetro / Glass



Astuccio con asola  
Pack with slot

Fig.	W	V			K	lm	Ra ≥	DIM			H mm	Ø mm	PCS		CBM m³		EAN 8009935	Code
- 1 -	4≈(40)	220-240	E14	360°	3000	470	80	SI	15.000	25.000	98	35	10	0,0012	ASA	101907	555280	
- 1 -	4≈(40)	220-240	E14	360°	4000	470	80	SI	15.000	25.000	98	35	10	0,0012	ASA	010124	555280.4K	
- 2 -	5≈(40)	220-240	E14	360°	3000	500	80	NO	15.000	25.000	98	35	10	0,0056	ASA	007483	555278.0101	

## Colpo di Vento - Bent-tip Candle / Tortiglione - Twisted Lamp

E14



Astuccio con asola  
Pack with slot

- 1 -

- 2 -

- 3 -

- 4 -

- 5 -

Vetro - Glass

Plastica - Plastic

Vetro - Glass

### Colpo di Vento - Bent-tip Candle

Fig.	W	V			K	lm	Ra ≥	DIM			H mm	Ø mm	PCS		CBM m³		EAN 8009935	Code
- 1 -	4≈(30)	220-240	E14	360°	3000	600	80	SI	15.000	25.000	131	37	10	0,0032	ASA	102041	555201	
- 1 -	6≈(40)	220-240	E14	360°	6000	600	80	SI	15.000	25.000	131	37	10	0,0032	ASA	102119	555202	
- 2 -	4≈(30)	220-240	E14	360°	3000	500	80	NO	15.000	25.000	125	35	10	0,0056	ASA	101310	555283.0101	
- 3 -	6≈(40)	220-240	E14	200°	6500	600	80	NO	15.000	25.000	131	37	10	0,0032	ASA	019745	555202.0101	

### Tortiglione - Twisted Lamp

Fig.	W	V			K	lm	Ra ≥	DIM			H mm	Ø mm	PCS		CBM m³		EAN 8009935	Code
- 4 -	5≈(40)	220-240	E14	360°	3000	500	80	NO	15.000	25.000	100	35	10	0,0056	ASA	101242	555282.0101	
- 5 -	5≈(40)	220-240	E14	360°	3000	500	80	NO	15.000	25.000	100	35	10	0,0056	ASA	008183	555351.0101	

## GU10

3CCT



- 1 -

Cod. RP0710

Emergenza per lampade LED a 230V. Batteria da ordinare separatamente (Cod. 00PB0800)  
Emergency for LED 230V LED lamps.  
Battery to be ordered separately (Cod. 00PB0800)



Fig.	W	V			K	lm	Ra ≥	DIM			H mm	Ø mm	PCS		CBM m³		Code
- 1 -	7≈(50)	220-240	GU10	36°	3000 / 4000 / 6000	700	80	-	15.000	25.000	56	50	10	0,0027	ASN	555304.3CCT	

# Goccia - GLS glass E27



- 1 -



- 2 -



- 3 -



Astuccio con asola  
Pack with slot

Vetro - Glass

Plastica - Plastic

Fig.	W	V			K	lm	Ra ≥	DIM			H mm	Ø mm	PCS	CBM m <sup>3</sup>	EAN 8009935	Code
- 1 -	8≈(75)	220-240	E27	360°	3000	1055	80	SI	15.000	25.000	106	55	10	0,0071	ASA 102188	555284
- 1 -	8≈(75)	220-240	E27	360°	6500	1055	80	SI	15.000	25.000	106	55	10	0,0071	ASA 102256	555285
- 1 -	8≈(75)	220-240	E27	360°	4000	1055	80	SI	15.000	25.000	106	55	10	0,0071	ASA 102324	555370
- 2 -	6≈(60)	220-240	E27	360°	3000	600	80	NO	15.000	25.000	105	60	10	0,0071	ASA 007346	555276.0101
- 2 -	6,5≈(60)	220-240	E27	360°	4000	806	80	NO	15.000	25.000	106	60	10	0,0038	ASA 007353	555276.4K
- 2 -	8≈(60)	220-240	E27	360°	3000	800	80	SI	15.000	25.000	105	60	10	0,0071	ASA 101129	555286.0101
- 2 -	8≈(75)	220-240	E27	360°	4000	1055	80	NO	15.000	25.000	106	60	10	0,0038	ASA 101143	555286.4K
- 2 -	6,5≈(75)	220-240	E27	360°	3000	608	80	SI	15.000	25.000	105	60	10	0,0071	ASA 009289	555383.0101
- 3 -	8,5≈(60)	220-240	E27	230°	3000	850	80	NO	15.000	25.000	111	60	10	0,0071	ASA 020659	555215.0101
- 3 -	11≈(75)	220-240	E27	230°	3000	1055	80	NO	15.000	25.000	108	60	10	0,0040	ASA 020871	555218.3K
- 3 -	15≈(150)	220-240	E27	230°	3000	1500	80	NO	15.000	25.000	127	67	10	0,0095	ASA 101396	555306.0101
- 3 -	15≈(150)	220-240	E27	230°	6500	1500	80	NO	15.000	25.000	127	67	10	0,0095	ASA 101532	555307.0101
- 3 -	17,5≈(115)	220-240	E27	230°	3000	1800	80	NO	15.000	25.000	140	70	10	0,0069	ASA 101549	555307.3K
- 3 -	17,5≈(115)	220-240	E27	230°	4000	1800	80	NO	15.000	25.000	140	70	10	0,0069	ASA 101556	555307.4K

## Goccia - GLS glass E27



- 1 -



- 2 -



- 3 -

### Vetro - Glass

Fig.	W	V			K	lm	Ra $\geq$	DIM			H mm	$\emptyset$ mm	PCS	CBM m <sup>3</sup>		EAN 8009935	Code
- 1 -	8≈(60)	220-240	E27	-	3000	800	80	SI	15.000	25.000	105	60	10	0,0071	ASA	008435	555359.0101
- 2 -	10≈(75)	220-240	E27	360°	2200	1000	80	SI	15.000	25.000	105	60	10	0,0071	ASA	008503	555362.0101
- 3 -	4≈(40)	220-240	E27	360°	2200	400	80	NO	15.000	25.000	140	60	10	0,00816	ASA	008534	555363.0101

## Crystal E14



- 1 -

### Cristallo - Crystal

Fig.	W	V			K	lm	Ra $\geq$	DIM			H mm	$\emptyset$ mm	PCS	CBM m <sup>3</sup>		EAN 8009935	Code	QTY	PROMO Euro Netto
- 1 -	3≈(25)	220-240	E14	360°	3000	300	80	NO	15.000	25.000	66	41	10	0,0035	ASN	020802	555235.0101	846	10,00

# MR16

12V



- 1 -

Fig.	W	V			K	lm	Ra ≥	DIM			H mm	Ø mm	PCS		CBM m³		EAN 8009935	Code
- 1 -	4≈(30)	12 AC/DC	GU5,3	36°	3000	400	80	NO	15.000	25.000	49	50	10		0,0027	ASN	128584	555064.0101
- 1 -	4≈(30)	12 AC/DC	GU5,3	36°	4000	400	80	NO	15.000	25.000	49	50	10		0,0027	ASN	004307	555065.0101

\* Fino ad esaurimento - Offer valid while supplies last



Per lampade dimmerabili vedi Pag. 625  
For dimmable lamps see Pag. 625

HL111

# G4

12V



- 2 -



- 2 -

Plastica - Plastic

Fig.	W	V			K	lm	Ra ≥	DIM			H mm	Ø mm	PCS		CBM m³		EAN 8009935	Code		
- 1 -	2,5≈(20)	12DC/AC	G4	250°	3000	250	80	NO	15.000	25.000	45	17	10		0,0058	ASN	102225	555296.0101		
- 1 -	2,5≈(25)	12DC/AC	G4	250°	4000	250	80	NO	15.000	25.000	45	17	10		0,0058	ASN	102294	555297.0101		
- 2 -	2,5≈(25)	12DC/AC	G4	250°	3000	230	80	NO	15.000	25.000	36	22	10		0,0058	ASN	102362	555298.0101	Netto 1,00	QTY* 1.180
- 2 -	2,5≈(25)	12DC/AC	G4	250°	4000	230	80	NO	15.000	25.000	36	22	10		0,0058	ASN	102430	555299.0101	Netto 1,00	QTY* 910

\* Fino ad esaurimento - Offer valid while supplies last

**MICRO LED TRAFI**  
Cod. RN9140



Trasformatore elettronico indipendente dimmerabile, per lampade alogene (20÷55W) e lampade a LED (3÷55W), 12Vac (\* max 3 lampade)  
Transformateur électronique indépendant dimmable, pour lampes halogènes (20÷55W) et lampes LED (3÷55W), 12Vac (\* max 3 lampes)

	Vac IN		Carico Load	W	Hz	ta °C	tc °C	Vout Vac
120x39x28	220-240	C	HALO	20÷55	50/60	-15...50	80	12
			LED *	3÷55				



Lampada alogena  
Halogen lamp  
12Vac - 20÷55W



Lampada LED  
LED lamp  
12Vac - 3÷55W - \* Max 3 Lamps

## R7s



- 1 -

Plastica - Plastic

Fig.	W	V			K	lm	Ra $\geq$	DIM			H mm	$\emptyset$ mm	PCS		CBM m <sup>3</sup>		EAN 8009935	Code
- 1 -	5≈(50)	85-265	R7s	360°	3000	500	83	SI	15.000	30.000	78	22	1		0,0001	ASA	102720	555316.0101
- 1 -	10≈(100)	85-265	R7s	360°	3000	1000	83	SI	15.000	30.000	118	22	1		0,0002	ASA	102508	555300.0101

## G9



- 1 -

Plastica - Plastic

Fig.	W	V			K	lm	Ra $\geq$	DIM			H mm	$\emptyset$ mm	PCS		CBM m <sup>3</sup>		EAN 8009935	Code
- 1 -	2≈(25)	220-240	G9	250°	4000	200	80	NO	15.000	25.000	53	17	10		0,0058	ASN	102010	555293.0101

## Globo - Globe lamp



- 1 -

Vetro - Glass



- 2 -

Plastica - Plastic



- 3 -



- 4 -

Vetro - Glass

Fig.	W	V			K	lm	Ra $\geq$	DIM			H mm	$\emptyset$ mm	PCS		CBM m <sup>3</sup>		EAN 8009935	Code
- 1 -	10≈(75)	220-240	E27	360°	3000	1000	80	SI	15.000	25.000	128	95	4		0,0153	ASA	102393	555209
- 1 -	10≈(75)	220-240	E27	360°	3000	1000	80	SI	15.000	25.000	175	125	4		0,0153	ASA	102461	555210
- 2 -	5≈(40)	220-240	E27	360°	3000	500	80	NO	15.000	25.000	128	95	4		0,0153	ASA	007230	555338.0101
- 2 -	5≈(40)	220-240	E27	360°	3000	500	80	SI	15.000	25.000	128	95	4		0,0153	ASA	007469	555339.0101
- 2 -	5≈(40)	220-240	E27	360°	3000	500	80	SI	15.000	25.000	175	125	4		0,0153	ASA	007162	555337.0101
- 2 -	10≈(75)	220-240	E27	360°	3000	1000	80	NO	15.000	25.000	175	125	4		0,0153	ASA	008695	555368.0101
- 2 -	10≈(75)	220-240	E27	360°	3000	1000	80	SI	15.000	25.000	175	125	4		0,0153	ASA	008718	555369.0101
- 3 -	9≈(60)	220-240	E27	300°	3000	900	80	NO	15.000	25.000	133	95	4		0,0175	ASA	020239	555209.0101
- 3 -	10≈(60)	220-240	E27	300°	3000	1000	80	SI	15.000	25.000	162	125	4		0,0183	ASA	020307	555210.0101
- 3 -	13≈(100)	220-240	E27	300°	3000	1300	80	NO	15.000	25.000	133	95	4		0,0175	ASA	020161	555208.0101
- 3 -	15≈(100)	220-240	E27	300°	3000	1500	80	SI	15.000	25.000	162	125	4		0,0183	ASA	020093	555207.0101
- 4 -	4≈(30)	220-240	E27	300°	2100	320	80	SI	15.000	15.000	190	150	6		-	ASA	508600	558108.0101
- 1 -	10≈(75)	220-240	E27	360°	4000	1000	80	SI	15.000	25.000	128	95	4		0,0153	ASA	8032979 492519	555371
- 1 -	10≈(75)	220-240	E27	360°	4000	1000	80	SI	15.000	25.000	175	125	4		0,0153	ASA	8032979 492601	555339



- 1 -



- 2 -

Vetro - Glass



- 3 -



- 4 -



- 5 -



- 6 -

Vetro - Glass

Fig.	W	V			K	lm	Ra ≥	DIM			H mm	Ø mm	PCS		CBM m³		EAN 8009935	Code	Euro netto	QTY
- 1 -	5≈(40)	220-240	E27	360°	2200	330	80	SI	15.000	25.000	175	125	4	0,0153	ASN	008084	555349.0101	Netto 4,90	QTY* 290	
- 2 -	5≈(30)	220-240	E27	360°	2200	330	80	SI	15.000	25.000	140	95	5	0,0088	ASN	617253	557217.0101	Netto 3,90	QTY* 145	
- 2 -	5≈(30)	220-240	E27	360°	2200	330	80	SI	15.000	25.000	175	125	4	0,0153	ASN	610643	557216.0101	Netto 4,90	QTY* 231	
- 3 -	5≈(40)	220-240	E27	300°	3000	330	80	SI	15.000	25.000	140	95	4	0,0153	ASN	009043	555374.0101			
- 3 -	5≈(40)	220-240	E27	300°	3000	330	80	SI	15.000	25.000	175	125	4	0,0153	ASN	009203	555377.0101			
- 4 -	5≈(40)	220-240	E27	300°	3000	330	80	SI	15.000	25.000	140	95	4	0,0153	ASN	008892	555373.0101	Netto 3,90	QTY* 181	
- 4 -	5≈(40)	220-240	E27	300°	3000	330	80	SI	15.000	25.000	175	125	4	0,0153	ASN	009111	555376.0101	Netto 4,40	QTY* 786	
- 5 -	5≈(40)	220-240	E27	300°	3000	330	80	SI	15.000	25.000	140	95	4	0,0153	ASN	008053	555348.0101	Netto 3,90	QTY* 659	
- 5 -	5≈(40)	220-240	E27	300°	3000	330	80	SI	15.000	25.000	175	125	4	0,0153	ASN	009050	555375.0101	Netto 4,40	QTY* 780	
- 6 -	5≈(30)	220-240	E27	300°	2700	330	80	SI	15.000	15.000	135	95	50	0,0153	ASN	012241	558109.0101			
- 6 -	5≈(30)	220-240	E27	300°	2700	330	80	SI	15.000	15.000	175	125	20	0,0153	ASN	012265	558110.0101			

\* Fino ad esaurimento - Offer valid while supplies last

# Lampade professionali a LED - Professional LED lamp

**5**  
Years  
warranty

**CRI >90**



Dimmerabile con alimentatore a corrente costante  
Dimmable with constant current power supply

LED MEISSA  
HL111 - G53

CDT



Codice Code	mA	W	Beam angle	K	N° LED	DIM	Vdc	ta °C	lm*	h.
R111MC/M/BC	350mA 12W	550mA 19W	25°	3000	1	OK	37	40	1650 2560	50.000
R111MC/W/BN	350mA 12W	550mA 19W	40°	4000	1	OK	37	40	1730 2700	50.000
R111MC/W/BC	350mA 12W	550mA 19W	40°	3000	1	OK	37	40	1650 2560	50.000
R111MC/60/BC	350mA 12W	550mA 19W	60°	3000	1	OK	37	40	1650 2560	50.000

LED Meissa - Dimensioni - Dimensions (mm)

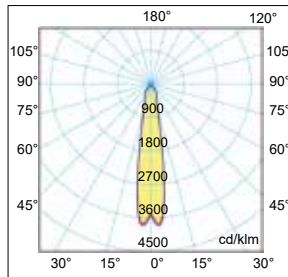
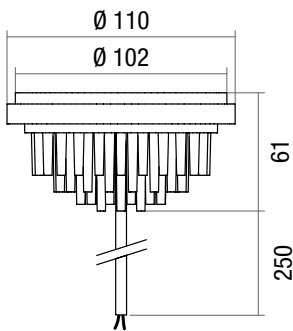

25°

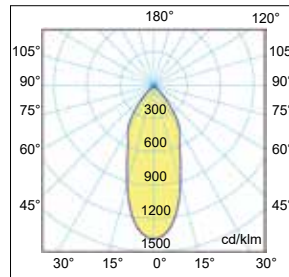

40°

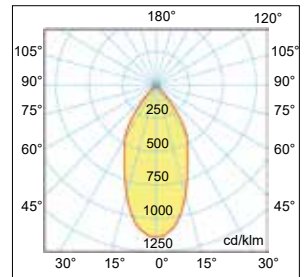

60°



Codice Code	mA MAX	W MAX	Beam angle	K	LED	DIM	Vdc	Nominal Lm (Tc =25°C)	Lm Output	Lm/W	PCS	CCM cm³
558118	700	18	120°	4000	LED SMD	OK	24	Max 3.200	Max 2.700	157	1	0,720

LED R7s / RX7s



Dimensioni (mm) - Dimensions (mm)

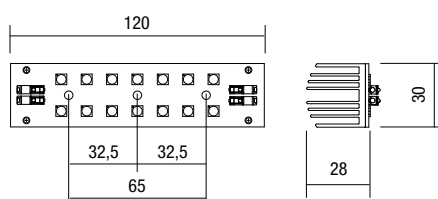

mA	500	600	700
W	11	13	15
Lm	1.812	2.314	2.700

# Lampade professionali a LED - Professional LED lamp

**5**  
Years  
warranty

**CRI >90**



Dimmerabile con alimentatore a corrente costante  
Dimmable with constant current power supply

## LED CHAMELEON NEW 25W

**HL111 - G53**



**CDT**

Codice Code	mA	W MAX	Beam Angle	K	N° LED	DIM	Vdc	Nominal Lm (Tc =25°C)	Lm Output	Lm/W
R111/25/25/BC	700	25	25°	3000	1	OK	37	3.825	3.000	120
R111/25/40/BC	700	25	40°	3000	1	OK	37	3.825	3.000	120
R111/25/60/BC	700	25	60°	3000	1	OK	37	3.825	3.000	120
R111/25/25/BN	700	25	25°	4000	1	OK	37	3.825	3.000	120
R111/25/40/BN	700	25	40°	4000	1	OK	37	3.825	3.000	120
R111/25/60/BN	700	25	60°	4000	1	OK	37	3.825	3.000	120
R111/25/25/27	700	25	25°	2700	1	OK	37	3.825	3.000	120
R111/25/40/27	700	25	40°	2700	1	OK	37	3.825	3.000	120
R111/25/60/27	700	25	60°	2700	1	OK	37	3.825	3.000	120

A richiesta: colorazione 5000K per min. 100 pz - **On request: 5000K coloring for min. 100 pcs**

## LED Chameleon - Dimensions (mm)

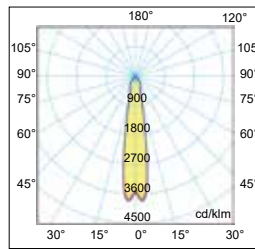
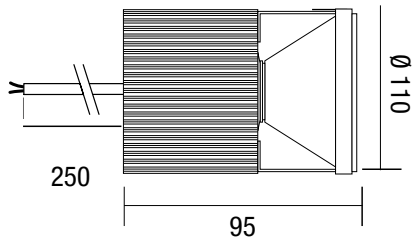

25°

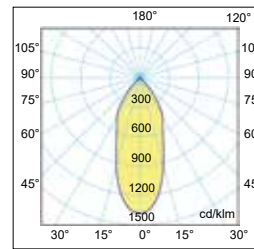

40°

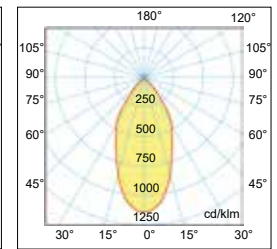

60°

## LED CHAMELEON NEW 50W

**HL111 - G53**



**CDT**

Codice Code	mA	W MAX	Beam Angle	K	N° LED	DIM	Vdc	Nominal Lm (Tc =25°C)	Lm Output	Lm/W
R111/50/25/BC	1400	50	25°	3000	1	OK	37	7.650	6.010	120
R111/50/40/BC	1400	50	40°	3000	1	OK	37	7.650	6.010	120
R111/50/60/BC	1400	50	60°	3000	1	OK	37	7.650	6.010	120
R111/50/25/BN	1400	50	25°	4000	1	OK	37	7.650	6.010	120
R111/50/40/BN	1400	50	40°	4000	1	OK	37	7.650	6.010	120
R111/50/60/BN	1400	50	60°	4000	1	OK	37	7.650	6.010	120
R111/50/25/27	1400	50	25°	2700	1	OK	37	7.650	6.010	120
R111/50/40/27	1400	50	40°	2700	1	OK	37	7.650	6.010	120
R111/50/60/27	1400	50	60°	2700	1	OK	37	7.650	6.010	120

A richiesta: colorazione 5000K per min. 100 pz - **On request: 5000K coloring for min. 100 pcs**

## LED Chameleon - Dimensions (mm)

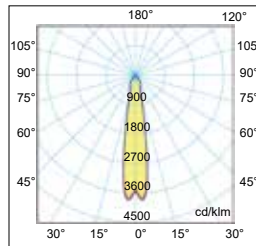
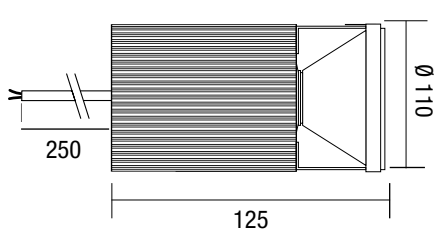

25°

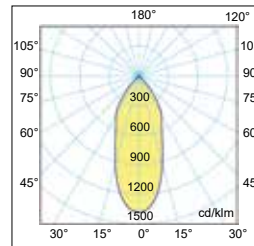

40°

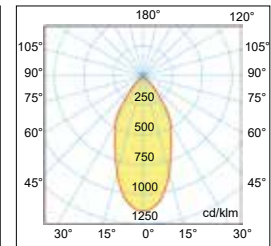

60°

LED CHAMELEON NEW 25W	
mA	W
350	13
500	18
600	22
700	25

LED CHAMELEON NEW 50W	
mA	W
800	29
900	32
1000	36
1100	40
1200	43
1300	47
1400	50



# Lampade professionali a LED - Professional LED lamp

**5**  
Years  
warranty

## LED NAPO - OPTOSPOT PAR16 - MR16



**CRI >90**



Dimmerabile con alimentatore a corrente costante  
Dimmable with constant current power supply

Cod.	W max	mA	Lm/W	Beam	K	N° LED	DIM	Vdc	lm	ta °C	h.
R16/D5/40/BC	8	700	110	Wide	3000	12	OK	9	880	45	50.000
R16/D5/40/BN	8	700	110	Wide	4000	12	OK	9	880	45	50.000
R16/D5/40/27	8	700	110	Wide	2700	12	OK	9	880	45	50.000
R16/D5/25/BC	8	700	110	Medium	3000	12	OK	9	880	45	50.000
R16/D5/25/27	8	700	110	Medium	2700	12	OK	9	880	45	50.000

### Dimensioni (mm) - Dimensions (mm)

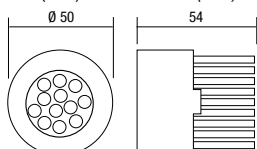

mA	W
200	2
300	3
400	4
500	5
600	6
700	8

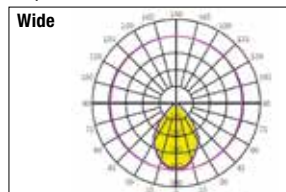
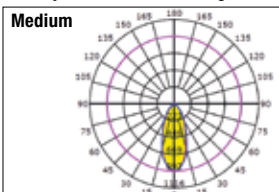

A richiesta: colorazione 5000K per min. 100 pz - **On request: 5000K coloring for min. 100 pcs**

## LED ATLAS - OPTOSPOT PAR16 - MR16



**CRI >90**



Dimmerabile con alimentatore a corrente costante  
Dimmable with constant current power supply

Cod.	W max	mA	Lm/W	Beam	K	N° LED	DIM	Vdc	lm	ta °C	h.
R16/M/BN/10	10	500	110	Medium	4000	7	OK	21	1100	45	50.000
R16/M/BC/10	10	500	110	Medium	3000	7	OK	21	1100	45	50.000
R16/M/27/10	10	500	110	Medium	2700	7	OK	21	1100	45	50.000
R16/W/BN/10	10	500	110	Wide	4000	7	OK	21	1100	45	50.000
R16/W/BC/10	10	500	110	Wide	3000	7	OK	21	1100	45	50.000
R16/W/27/10	10	500	110	Wide	2700	7	OK	21	1100	45	50.000

### Dimensioni (mm) - Dimensions (mm)

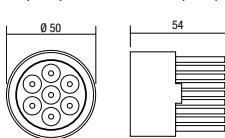

mA	W
250	5
350	7
500	10

A richiesta: colorazione 5000K per min. 100 pz - **On request: 5000K coloring for min. 100 pcs**

## LED VIOLA - OPTOSPOT PAR16 - MR16



**CRI >90**



Dimmerabile con alimentatore a corrente costante  
Dimmable with constant current power supply

Cod.	W max	mA	Beam	K	N° LED	DIM	Vdc	lm	ta °C	h.
R16COB/25/BC	13	350	Medium	3000	1 COB	OK	36	1550	45	50.000
R16COB/40/BC	13	350	Wide	3000	1 COB	OK	36	1550	45	50.000
R16COB/25/BN	13	350	Medium	4000	1 COB	OK	36	1700	45	50.000
R16COB/40/BN	13	350	Wide	4000	1 COB	OK	36	1700	45	50.000
R16COB/25/27	13	350	Medium	2700	1 COB	OK	36	1700	45	50.000
R16COB/40/27	13	350	Wide	2700	1 COB	OK	36	1700	45	50.000

### Dimensioni (mm) - Dimensions (mm)

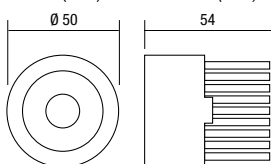

mA	W
200	7
250	9
300	11
350	13

A richiesta: colorazione 5000K per min. 100 pz - **On request: 5000K coloring for min. 100 pcs**



### Medium

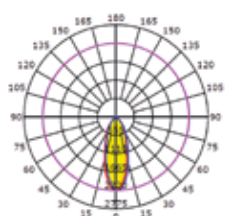

### Wide

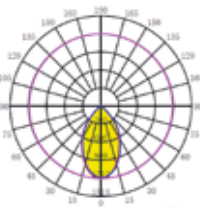

## TRAF0 per HALO-LED TBT 12Vac - HALO-LED TRAF0 TBT 12Vac



**Lampada alogena tradizionale**  
*Traditional halogen lamp*  
12Vac - 20÷55W



R111



G4



MR16

**Lampada LED dimmerabile**  
*Dimmable LED lamp*  
12Vac - 3÷55W  
\* Max 4 / 5 Lamps



RN9140



Dimensioni (mm) - *Dimensions (mm)*

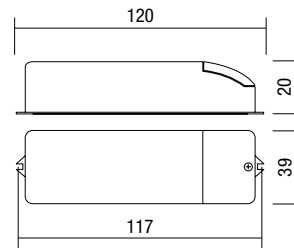

**Norme di riferimento**  
*Reference norms*

EN 55015  
EN 61000-3-2  
EN 61000-3-3  
EN 61347-1  
EN 61347-2-13  
EN 61547  
EN62384

Codice Code	LPH mm	Vac IN	DIM	Carico Load	W	Hz	ta °C	tc °C	Vout Vac	PCS	CCM cm <sup>3</sup>
RN9140	120x39x28	220-240	C	HALO LED	20÷55 3÷55	50/60	-15...50	80	<b>12</b>	25	6.800

### Caratteristiche tecniche

Trasformatore elettronico indipendente dimmerabile, per lampade alogene (20÷55W) e lampade a LED (3÷55W), 12Vac (max 4/5 lampade)

- Protetto in classe II contro le scosse elettriche per contatti diretti e indiretti
- Fornito di coprimersetto e fermacavo
- Morsetti di entrata e di uscita sullo stesso lato
- Fissaggio con asole per viti
- Protezioni: termica, sovraccarico, sovratensione
- Regolazione con dimmer GBT

### Technical features

Dimmable independent electronic transformer halogen lamps (20÷55) and LED lamps (3÷55W), 12Vac (max 4/5 lamps)

- Class II protection against electric shocks by direct and indirect contact
- Supplied with terminal cover and cable clip
- Input and output terminal on the same side
- Fixing for slots for screws
- Protection: thermal, overload, overvoltage
- Regulation with IGBT dimmer

## TRAF0 VARIALUCE HALO-LED TBT 12Vac - MAX 60W TRAF0 DIMMER HALO-LED TBT 12Vac - MAX 60W



Codice Code	Colore Colour	LPH mm	Vac IN	Carico Load	W	Hz	ta °C	Vout Vac	PCS	CCM cm <sup>3</sup>
RL7317HALED	N	109x61x35	220-240	HALO LED	20÷60 3÷60	50/60	-15...35	<b>12</b>	25	6.800
RL7317HALEDT	T	109x61x35	220-240	HALO LED	20÷60 3÷60	50/60	-15...35	<b>12</b>	25	6.800



Dimensioni (mm)  
*Dimensions (mm)*

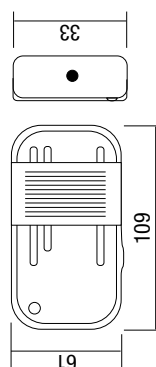

**Norme di riferimento - Reference norms**

EN61347-1	Sicurezza Safety
EN61347-2-2	
EN61047	Prestazioni Performance
EN61000-3-2	Limiti armonici Harmonic limits
EN55015	Emissioni R.F.I. - R.F.I. emission
EN61547	Immunità Immunity
EN61000-3-3	Flickers

# TRAFO VARIALUCE TOUCH HALO-LED TBT 12Vac - MAX 60W

## TRAFO DIMMER TOUCH HALO-LED TBT 12Vac - MAX 60W



Lampada alogena tradizionale  
*Traditional halogen lamp*  
12Vac - 20÷55W



R111



G4



MR16

Lampada LED dimmerabile  
*Dimmable LED lamp*  
12Vac - 3÷55W  
\* Max 4 / 5 Lamps



Codice Code	Colore Colour	LPH ↓mm	Vac IN	Carico Load	W	Hz	ta °C	Vout Vac	PCS	CCM cm <sup>3</sup>
RL7323HALEDS	N	106x57x34	220-240	HALO LED *	20÷60 3÷60	50/60	-15...35	12	25	6.800
RL7323HALEDST	T	106x57x34	220-240	HALO LED *	20÷60 3÷60	50/60	-15...35	12	25	6.800
RL7327HALEDPS	N	106x57x34	220-240	HALO LED *	20÷60 3÷60	50/60	-15...35	12	25	6.800

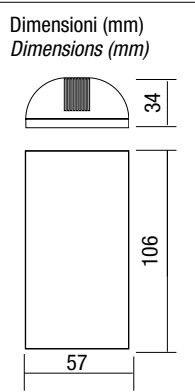
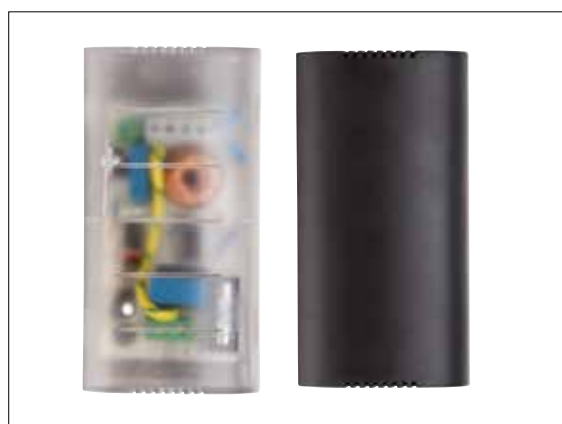

### Caratteristiche tecniche

**Trasformatore elettronico indipendente dimmerabile, per lampade alogene E LED**

- Regolazione sensoriale o a pulsante continua
- Sensore indipendente dalla polarità di rete
- Distanza tra scheda e sensore: MAX 2 m
- Memoria d'intensità luminosa anche in assenza di rete
- Accensione graduale / Spegnimento graduale
- Accensione da presa comandata

### Technical features

**Dimmable independent electronic transformer halogen lamps and LED lamps**

- Continuous sensorial or push button regulation
- No line plug polarity
- Maximum distance between circuit and control point 2 meters
- The light level is memorized unless the mains supply is cut off
- Soft start / Soft stop
- Switch-on from wall socket

**S** = Controllo a sfioramento - *Touch control*

**PS** = Controllo a pulsante  
*Push button control*

### Trasformatore elettronico indipendente dimmerabile, per lampade alogene e LED dimmerabili

- Regolazione sensoriale o a pulsante continua
- Sensore indipendente dalla polarità di rete
- Distanza tra scheda e sensore: MAX 2 m
- Memoria d'intensità luminosa anche in assenza di rete
- Accensione graduale / Spegnimento graduale
- Accensione da presa comandata

### Installazione

L'alimentatore elettronico deve essere impiegato esclusivamente su apparecchi di illuminazione in classe III. Rispettare i dati di targa, posizionare l'alimentatore lontano da fonti di calore. Limitare a 2 metri la lunghezza del cavo di collegamento al carico.

### Dimmable independent electronic transformer halogen and LED lamps dimmable

- Continuous sensorial or push button regulation
- No line plug polarity
- Maximum distance between circuit and control point 2 meters
- The light level is memorized unless the mains supply is cut off
- Soft start / Soft stop
- Switch-on from wall socket

### Installation

Use exclusively with lighting fixtures in Class III. Respect plate values indicated, keep transformer far from direct heat sources. Distance of connecting cable to load should not exceed 2 metres.



# DRIVER CC



POWERLED

CDT



350mA  
700mA

Dimensioni (mm) - Dimensions (mm)

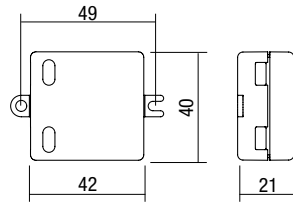

Norme di riferimento  
Reference norms

EN 55015  
EN 61000-3-2  
EN 61000-3-3  
EN 61347-1  
EN 61347-2-13  
EN 61547  
EN62384

Codice Code	LPH $\downarrow$ mm	Vdc IN	Vac IN	Hz	W	n°LED (min-max)	10A?	iC	Vout Vdc	ta °C	tc °C	PFC	Iout mA	PCS	CCM cm³
PTDCC/3/350/N	42x40x21	176-264	95-240	50/60	5	1-5	30	10A 40µS	Max 16	-20..60	80	*	350	50	1.734
PTDCC/3/700/N	42x40x21	-	220-240	50/60	3	1	30	10A 40µS	Max 5	-20..60	80	*	700	50	1.734

\* Per potenze inferiori a 24W non è richiesto dalle normative - For lower powers to 24W is not required by the regulations

- Uscita in corrente costante (CDT)
- Protetto in classe II contro le scosse elettriche per contatti diretti e indiretti
- Apparecchiatura da incorporare
- Dimensioni molto ridotte e compatte
- Morsetti di entrata e uscita sullo stesso lato
- Protezioni: Termica, sovraccarico, sovratensione e cortocircuito
- Non è possibile l'accensione e lo spegnimento sul secondario per LED alimentati in corrente
- CDT connessione moduli LED in SERIE
- Constant current output (CDT)
- Class II protection against electric shock following direct or indirect contact
- Driver for built-in use
- Ultra compact size
- Input and output terminals on the same side
- Protection: thermal, overload, overvoltage and short circuit
- Cannot be switched on and off on secondary circuit for power Led
- CDT connessione LED moduli in SERIE

# DRIVER CC - CV



CDT VDT

Dimensioni (mm) - Dimensions (mm)

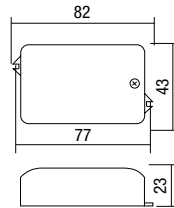

Norme di riferimento  
Reference norms

EN 55015  
EN 61000-3-2  
EN 61000-3-3  
EN 61347-1  
EN 61347-2-13  
EN 61547  
EN62384

Codice Code	LPH $\downarrow$ mm	Vdc IN	Vac IN	Hz	10A?	iC	ta °C	tc °C	PFC	PCS	CCM cm³
RN1393	82x43x23	-	220-240	50/60	30	10A - 40µS	-15..45	70	*	100	10.166
RN1397	82x43x23	-	220-240	50/60	30	10A - 40µS	-15..45	70	*	100	10.166

RN1393				RN1397			
		CDT	VDT			CDT	VDT
Iout	mA	350	330	Iout	mA	700	660
Vout	Vdc	24	24	Vout	Vdc	12	12
Power	W	8	8	Power	W	8	8
N° LED	min-max	1÷7	-	N° LED	min-max	1÷3	-

\* Per potenze inferiori a 24W non è richiesto dalle normative - For lower powers to 24W is not required by the regulations

- Uscita in corrente e tensione costante.
- Protetto in classe II contro le scosse elettriche per contatti diretti e indiretti
- Selezione automatica della corrente o della tensione in uscita
- Apparecchiatura per uso indipendente
- Morsetti di entrata e uscita contrapposti
- Fissaggio con asole per viti
- Protezioni: Termica, sovraccarico, sovratensione e cortocircuito
- Non è possibile l'accensione e lo spegnimento sul secondario per LED alimentati in corrente
- CDT connessione moduli in SERIE
- VDT connessione moduli LED in PARALLELO
- Constant current and voltage output
- Class II protection against electric shock following direct or indirect contact
- Automatic selection of voltage or current output
- Independent driver
- Opposite input and output terminal blocks
- Driver can be secured with slot for screws
- Protection: thermal, overload, overvoltage and short circuit
- Cannot be switched on and off on secondary circuit for power Led
- CDT connessione moduli in SERIE
- VDT connection LED modules in PARALLEL



# ICE LED CC

## Alimentatore elettronico multipotenza - LED Driver multipower

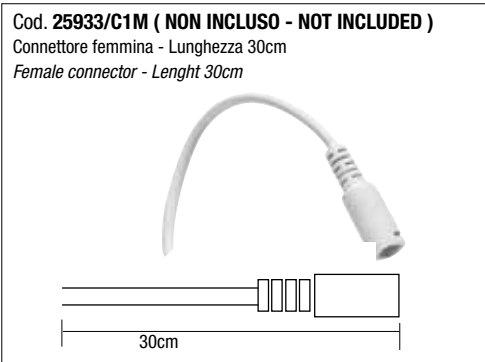
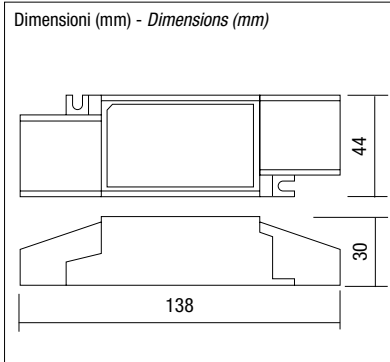

Codice Code	Vdc IN	Vac IN	Hz	SELV	iC	ta °C	tc °C	PFC	PCS	CCM cm³
RN9164/FAST	230-280	220-240	50/60	25	20A 170µS	-20..50	75	OK	15	1.720
<b>Iout</b>	mA	700	750	800	850	900	950	1000	1050	
<b>Vout</b>	Vdc	20-42	20-42	20-42	20-42	20-42	20-42	20-42	20-42	20-42
<b>Power</b>	W	28	30	32	34	36	38	40	42	
<b>N° LED typical VF 3,2V</b>	min-max	7-12	7-12	7-12	7-12	7-12	7-12	7-12	7-12	7-12

Taratura di fabbrica - Factory setting      COB - Typical VF 37V



# DRIVER 1-10V

## Alimentatore elettronico multipotenza - LED Driver multipower



Norme - Reference norms

- EN 55015
- EN 61000-3-2
- EN 61000-3-3
- EN 61347-1
- EN 61347-2-13
- EN 61547
- EN62384
- EN62386-101
- EN62386-102
- EN62386-207



Codice Code	Vdc IN	DIM	Vac IN	DIM	Hz	SELV	iC	ta °C	tc °C	PFC	LxPxH (mm)	PCS	CCM cm³
RN9160	176÷264	S10	110÷240	P - R - S10	50/60	25	20A 170µS	-20..40	75	OK	118x52x22	20	6.800
RN9168	176÷264	S10	110÷240	P - R - S10	50/60	15	25A 200µS	-20..45	80	OK	124x80x34	10	7.546

**RN9160**

	mA	200	250	300	350	400	450	500	550	600	650	700	750	800	850	900	950
<b>Iout</b>																	
<b>Vout</b>	Vdc	42	42	42	42	42	42	40	36	33	31	29	27	25	24	22	21
<b>Power</b>	W	8	10	12 (10)	15 (10)	17 (10)	19 (10)	20 (10)	20 (10)	20 (10)	20 (10)	20 (10)	20 (10)	20 (10)	20 (10)	20 (10)	20 (10)
<b>N° LED typical VF 3,2V</b>	min-max	1÷13	1÷13	1÷13	1÷13	1÷13	1÷13	1÷12	1÷11	1÷10	1÷9	1÷8	1÷8	1÷7	1÷7	1÷6	1÷6

COB - Typical VF 37V

**RN9168**

	mA	600	700	800	900	1000	1100	1200	1300	1400	1500	1600	1700	1800	1900	2000	2100
<b>Iout</b>																	
<b>Vout</b>	Vdc	45	45	45	45	45	45	45	42	39	37	34	32	31	29	28	26
<b>Power</b>	W	25	30	35	40	45	50	55	55	55	55	55	55	55	55	55	55
<b>N° LED typical VF 3,2V</b>	min-max	1÷14	1÷14	1÷14	1÷14	1÷14	1÷14	1÷14	1÷13	1÷12	1÷11	1÷10	1÷10	1÷9	1÷9	1÷8	1÷8

COB - Typical VF 37V

- Uscita in corrente costante (CDT)
- Morsetti di entrata e uscita contrapposti (RN9164/FAST)
- Morsetti di entrata e uscita sullo stesso lato (RN9160 - RN9168)
- Fissaggio con asole per viti
- Protezioni: Termica, sovraccarico, sovratensione e cortocircuito

- Constant current output (CDT)
- Opposite input and output terminals (RN9164/FAST)
- Input and output terminals on the same side (RN9160 - RN9168)
- Driver can be secured with slot for screws
- Protections: against short circuit, against extra network voltage, against overloads.

# FD serie FLEXIBLE DRIVER CC - Alimentatori elettronici in corrente continua con dip-switch

## Direct current electronic driver with dip-switch

### Caratteristiche tecniche

- Alimentatore multipotenza fornito di dip-switch per la selezione della corrente in uscita.
- Alimentatore indipendente IP20, per uso interno
- Protetto in classe II contro le scosse elettriche per contatti diretti e indiretti
- Alimentatore da incorporare.
- Utilizzabile per apparecchi di illuminazione in classe I e II
- PFC attivo
- Corrente regolata  $\pm 5\%$  incluse variazioni di temperatura.
- Morsetti di entrata e di uscita contrapposti (sezione cavo fino a 1,5mm<sup>2</sup> / AWG15)
- Serracavo su primario e secondario per cavi di diametro : min 2mm - max 11mm
- Fissaggio dell'alimentatore tramite asole per viti.
- Protezioni: al cortocircuito, contro le extra-tensioni di rete e contro i sovraccarichi.
- Protezione termica: = C.5.A
- Coprimorsetti **INCLUSI**

### Technical features

- Multi-power supply equipped with dip-switch for selecting the current output.
- Independent IP20 power supply, for internal use
- Protected in class II against electric shock for direct and indirect contact
- Power supply to be incorporated.
- Can be used for class I and II lighting fixtures
- Active PFC
- Regulated current  $\pm 5\%$  including temperature variations.
- Opposing input and output terminals (cable section up to 1.5mm<sup>2</sup> / AWG15)
- Cable clamp on primary and secondary for cables with diameters: min 2mm max 11mm
- Fixing of the power supply via screw slots.
- Protections: against short circuits, against extra mains voltages and against over loads.
- Thermal protection: = C.5.A
- Terminal block **INCLUDED**



Dimensioni (mm) - Dimensions (mm)

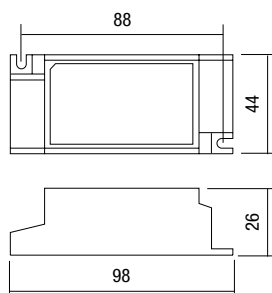

### Norme di riferimento Reference norms

EN 55015  
EN 61000-3-2  
EN 61000-3-3  
EN 61347-1  
EN 61347-2-13  
EN 61547  
EN62384  
VDE 0710-T14



Dimensioni (mm) - Dimensions (mm)

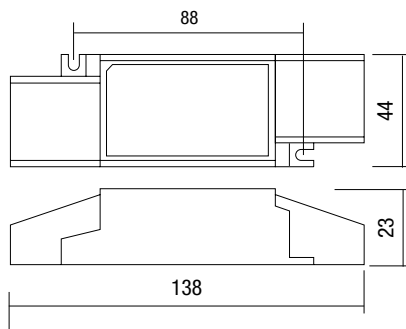

	Codice Code	Vdc IN	Vac IN	DM	Hz	ic	ta °C	tc °C	PFC	PCS
	RN8166	180-280	220-240	DALI 2 PUSH	50/60	20A - 175µS	45	85	OK	50
	RN8167	180-280	220-240	ON - OFF	50/60	20A - 175µS	45	85	OK	50



### RN8166DAPUFAS - RN8167FAST

Completo di cavo per connessione rapida  
Complete with quick connection cable

# FD serie FLEXIBLE DRIVER - Alimentatori elettronici in corrente continua con dip-switch

## Direct current electronic driver with dip-switch

RN8167 - ON/OFF

Pout (W)	Iout (mA)	Vdc	1	2	3	4
13,5	300	9÷45	-	-	-	-
15,8	350		-	-	-	ON
18,0	400		-	-	ON	-
20,3	450		-	-	ON	ON
22,5	500		-	ON	-	-
24,8	550		-	ON	-	ON
27,0	600		-	ON	ON	-
29,3	650		-	ON	ON	ON
31,5	700		ON	-	-	-
33,8	750		ON	-	-	ON
36,0	800		ON	-	ON	-
38,3	850		ON	-	ON	ON
40,5	900		ON	ON	-	-
39,9	950		ON	ON	-	ON
42,0	1000	9÷42	ON	ON	ON	-
44,1	1050		ON	ON	ON	ON

RN8166 - DALI PUSH



1	2	3	4	Pout (W)	Iout (mA)	Vdc
-	-	-	-	14,7	300	9÷49
-	-	-	ON	17,2	350	
-	-	ON	-	19,6	400	
-	-	ON	ON	22,1	450	
-	ON	-	-	24,5	500	
-	ON	-	ON	27,0	550	
-	ON	ON	-	29,4	600	
-	ON	ON	ON	31,9	650	
ON	-	-	-	34,3	700	
ON	-	-	ON	36,0	750	
ON	-	ON	-	36,0	800	
ON	-	ON	ON	38,3	850	
ON	ON	-	-	40,5	900	
ON	ON	-	ON	39,9	950	
ON	ON	ON	-	42,0	1000	
ON	ON	ON	ON	44,1	1050	
						9÷42

**ACCESSORIO:** consente il looping dei cavi di ingresso. Struttura robusta, compatibile con cavi di sezione differente  
**ACCESSORY:** enables looping of the input cables. Sturdy structure, compatible with cables of different section

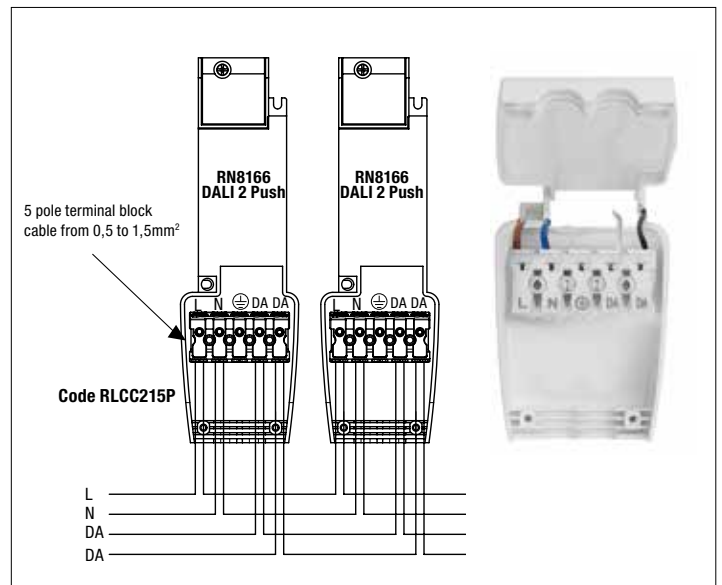
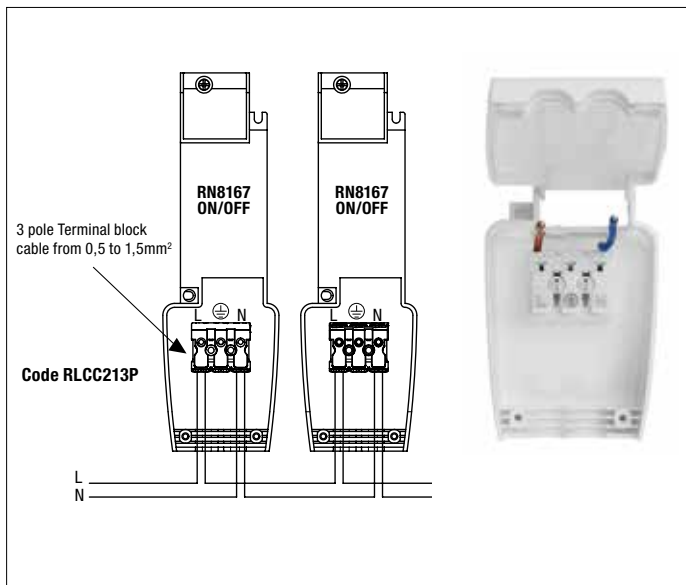

Esempio applicativo - Application example

**CLACK!**



# FD serie FLEXIBLE DRIVER - Alimentatori elettronici in corrente continua con dip-switch

## Direct current electronic driver with dip-switch

### RN8166 DALI PUSH

#### Sistemi di regolazione

**DALI** = sistema DALI 2 (Fig. 1)

**PULSANTE** = controllo a pulsante. **Mantenimento della memoria anche in assenza di rete** (Fig. 2)

**SINCRONIZZAZIONE PULSANTE** = Durante il funzionamento normale, o anche nel caso di sostituzione, per manutenzione di uno dei driver, potrebbe accadere che non risultino sincronizzati tra loro, per sincronizzare nuovamente tutti i driver è sufficiente premere il pulsante di regolazione per 10 secondi, passato questo tempo, tutti i driver si porteranno al 50% della potenza e risulteranno così nuovamente sincronizzati tra loro.

Questa procedura può essere effettuata in qualunque momento durante il normale funzionamento, quando si dovesse notare una differenza di regolazione su uno qualsiasi dei driver collegati.

### RN8166 DALI PUSH

#### Regulation systems

**DALI** = DALI 2 system (Fig. 1)

**PUSH** = push button control. **Memory retention even in the absence of mains voltage.** (Fig. 2)

**PUSH BUTTON SYNCHRONIZATION** = During normal operation, or even in the case of replacement, for maintenance, of one of the drivers, it could happen that they are no longer synchronized with each other, to solve the problem and synchronize all the levels again, simply press and hold the button adjustment for 10 seconds, after this time, all the drivers will reach 50% of the power and will thus be synchronized with each other again.

This procedure can be carried out at any time during normal operation, when a difference in regulation should be noted on any of the connected drivers.

Fig. 1 - Regolazione DALI 2 - DALI 2 control

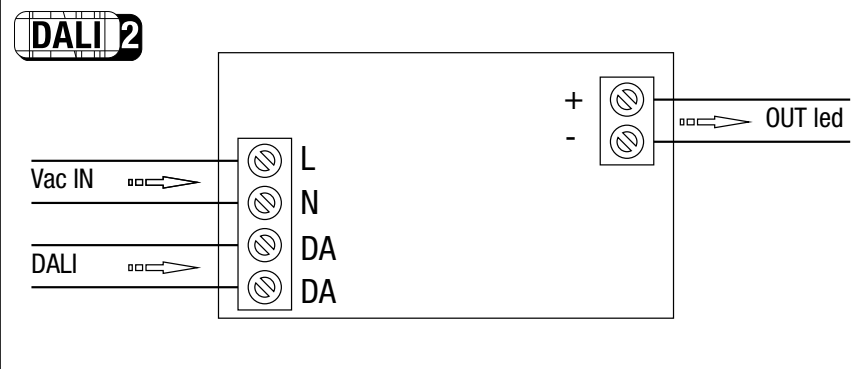

Fig. 2 - Regolazione DALI 2 PUSH - DALI 2 PUSH control

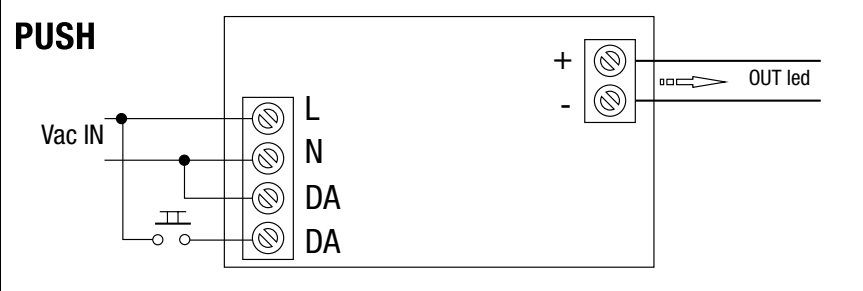
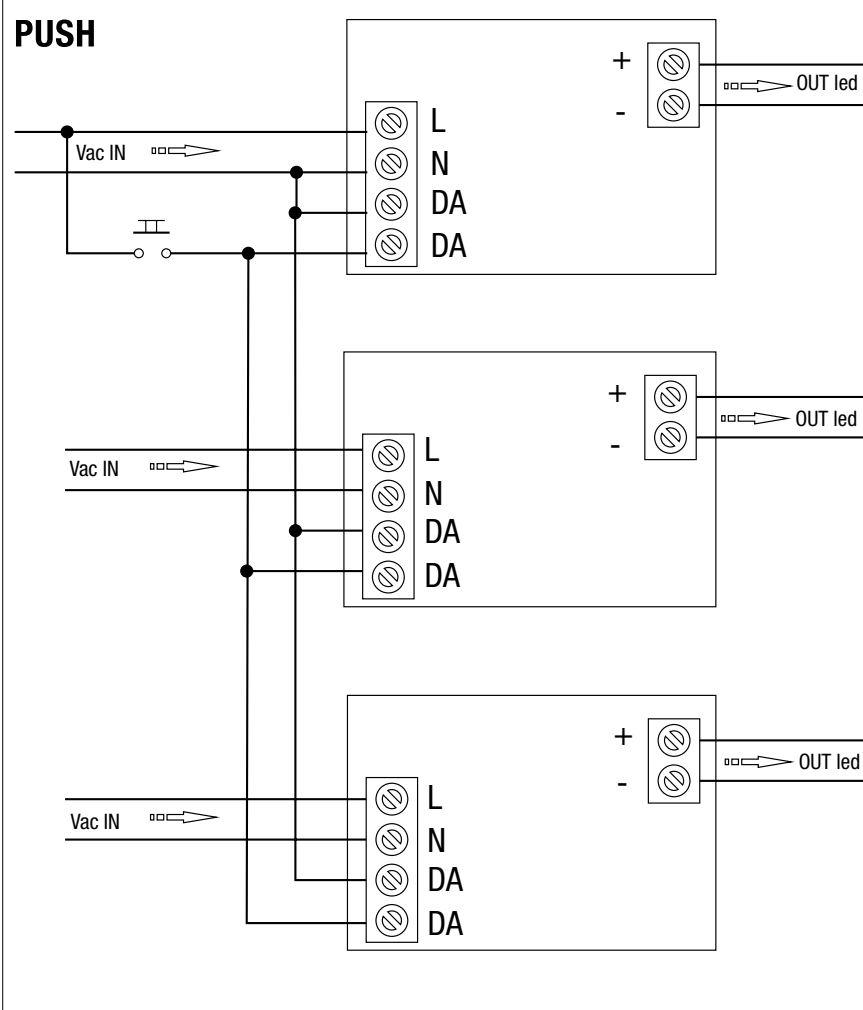

Fig. 3 - Esempio applicativo controllo pulsante - Push button control application example



# TGV 36 CC - TGV 36DA CC - Alimentatore elettronico in corrente continua con dip-switch

## Direct current electronic driver with dip-switch



Coprimorsetti NON INCLUSI (da ordinare a parte RN7136)  
Terminal cover NOT INCLUDED (ordinarily a part RN7136)  
Coprimorsetti INCLUSI (RN7136DA)  
Terminal cover INCLUDED (RN7136DA)  
Cod. 7136TB

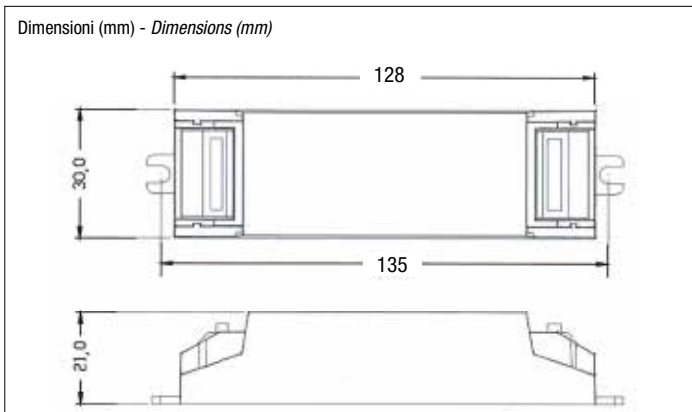
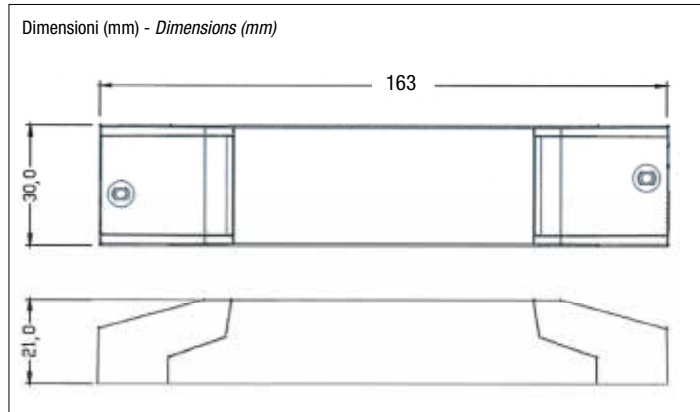

	Codice Code	Vdc IN	Vac IN	DIM	Hz	iC	ta °C	tc °C	PFC	PCS
<b>DALI 2 PUSH</b>	RN7136DA	180-280	220-240	DALI 2 PUSH	50/60	8,5A - 16µS	50	90	OK	10
	RN7136	180-280	220-240	ON - OFF	50/60	8,5A - 16µS	50	90	OK	50

### Dati tecnici

- Alimentatore multipotenza, dotato di DIP switch per la selezione della corrente in uscita
- Alimentatore per uso indipendente IP20
- Classe di protezione II contro le scosse elettriche con contatto diretto e indiretto
- Alimentazione per soluzioni da incasso
- Adatto per luci delle classi I e II
- PFC attivo
- Regolazione corrente  $\pm 5\%$  comprese le fluttuazioni di temperatura.
- Morsetti di entrata e di uscita contrapposti (sezione del cavo fino a 1,5 mm<sup>2</sup>/AWG15)
- Cavo di collegamento alla parte iniziale e secondaria per il diametro del cavo: minimo 2 mm - massimo 11 mm
- Fissaggio dell'alimentatore tramite asole per viti.
- Misure di protezione: cortocircuito, contro le sovratensioni di rete e sovraccarichi.
- Protezione termica: = C.5.A

### Technical data

- Multi-power power supply, equipped with DIP switch for selecting the output current
- IP20 power supply for independent use
- Protection class II against electric shock with direct and indirect contact
- Power supply for built-in solutions
- Suitable for class I and II lights
- Active PFC
- Current regulation  $\pm 5\%$  including temperature fluctuations.
- Opposing input and output terminals (cable section up to 1.5 mm<sup>2</sup>/AWG15)
- Connection cable to the initial and secondary part for the cable diameter: minimum 2 mm - maximum 11 mm
- Fixing of the power supply via screw slots.
- Protection measures: short circuit, against mains overvoltages and overloads.
- Thermal protection: = C.5.A

out	mA	150	200	250	300	350	400	450	500	550	600	650	700	750	800	850	900
Vout	Vdc	2,5-50	2,5-50	2,5-50	2,5-50	2,5-50	2,5-50	2,5-50	2,5-50	2,5-50	2,5-50	2,5-50	2,5-50	2,5-42	2,5-42	2,5-42	2,5-40
Power	W	7,5	10,0	10,0	15,0	17,5	20	22,5	25	27,5	30,0	32,5	35,0	31,5	33,6	35,7	36,0
N° LED typical VF 3,2V	min-max	1-15	1-15	1-15	1-15	1-15	1-15	1-15	1-15	1-15	1-15	1-15	1-15	1-13	1-13	1-13	1-12

COB - Typical VF 37V

# MULTIPOWER "SLIM" LED DRIVER CC NON-ISOLATED



**POWERLED 200 - 250 - 300 - 350**  
Cod. RN9133-200350



Impostazione della corrente  
tramite DIP-SWITCH

Dimensioni (mm) - Dimensions (mm)

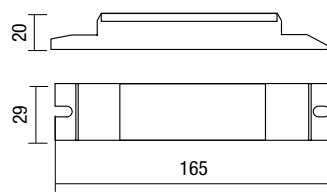

**Norme di riferimento**  
**Reference norms**

EN 55015  
EN 61000-3-2  
EN 61000-3-3  
EN 61347-1  
EN 61347-2-13  
EN 61547  
EN62384  
EN62386-101  
EN62386-102  
EN62386-207

**POWERLED 350 - 400 - 450 - 500**  
Cod. RN9133-350500



Impostazione della corrente  
tramite DIP-SWITCH

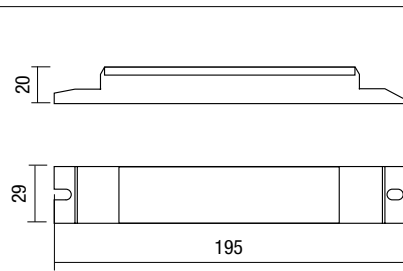

Dip-Switch per la selezione della  
corrente in uscita.

*Equipped with Dip-Switch  
for selection the output current.*



Codice Code	Vdc IN	DM	Vac IN	DM	Hz	THD	iC	ta °C	tC °C	PFC	PCS	CCM cm²
RN9133-200350	200-250	NO	220-240	NO	50/60	30	27A 380 µS	-20...+55	80	OK	50	34.875
RN9133-350500	200-250	NO	220-240	NO	50/60	17	46A 480 µS	-20...+55	75	OK	50	34.875

**RN9133-200350**

lout	mA	200	250	300	350
Vout	Vdc	40÷200	40÷160	40÷135	40÷115
Power	W	8÷40	10÷40	12÷40	14÷40
N° LED	min	13	13	13	13
	max	34	34	34	34

COB - Typical VF 37V

**RN9133-350500**

lout	mA	350	400	450	500
Vout	Vdc	40÷230	40÷200	40÷177	40÷160
Power	W	14÷80	16÷80	18÷80	14÷80
N° LED	min	13	13	13	13
	max	50	55	60	70

COB - Typical VF 37V

**POWERLED 350 - 400 - 450 - 500**  
Cod. RN9133/DALI

**DALI 2 PUSH**

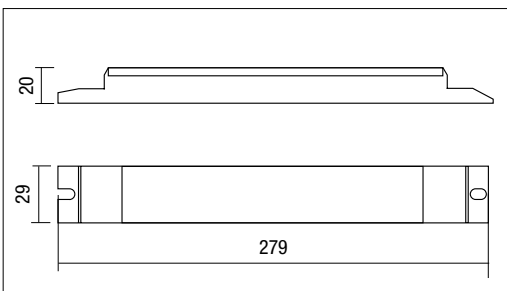

**120-550 DALI NFC (non -isolated)**

**DALI 2 PUSH**

Codice Code	Corrente di uscita Output current	Corrente di entrata Input current	Potenza in ingresso Input power	Potenza in uscita Output power range	PF	Efficienza Efficiency	Tensione di uscita Output voltage	Tensione senza carico No load voltage
RN9133/DALI	120-550 mA	≤ 0.30A	64.4W	6.48 - 60.00W	≥ 0.95	94%	54-240Vdc	-25..50

# U-BOOT - LED Driver CC

LED Driver per i principali binari trifase in commercio

LED Drivers for the most common three-phase track on the market



## U-BOOT



### Dimensioni (mm) - Dimensions (mm)

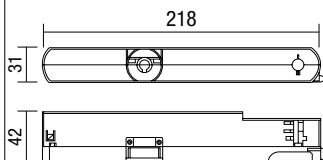

RL4600 - RL4610

### Dimensioni (mm) - Dimensions (mm)

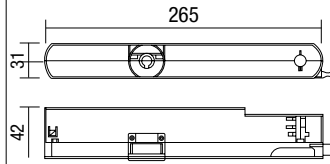

RL4630 - RL4650



Codice Code	Dip Switch	Colore Color	Vdc IN	DM	Vac IN	DM	Hz	GLOBAL	iC	ta °C	tc °C	PFC	PCS	CCM cm³
RL4600	Tab. 2	B	-	NO	220-240	NO	50/60	25	20A 170 µS	-20...35	75	OK	50	34.875
RL4610	Tab. 2	N	-	NO	220-240	NO	50/60	25	20A 170 µS	-20...35	75	OK	50	34.875
RL4630	Tab. 2	B	176-280	DALI 2	220-240	DALI	50/60	25	20A 170 µS	-20...35	75	OK	50	34.875
RL4650	Tab. 2	N	176-280	DALI 2	220-240	DALI	50/60	25	20A 170 µS	-20...35	75	OK	50	34.875

Tabella 2 - Table 2 - Disp switch selection

1	2	3	4	5	Iout mA	W	Vout Vdc	Vin Vac
					300	13	10÷42	220-240
				ON	350	15		
			ON		400	17		
			ON	ON	450	19		
		ON			500	21		
		ON		ON	550	23		
		ON	ON		600	25		
		ON	ON	ON	650	27		
ON	ON				700	29		
ON	ON			ON	750	32		
ON	ON		ON		800	34	10÷40	
ON	ON		ON	ON	850	34		
ON	ON	ON			900	36		
ON	ON	ON		ON	950	38		
ON	ON	ON	ON		1000	40		
ON	ON	ON	ON	ON	1050	42		

RL4600 - RL4610 - RL4630 - RL4650		CDT															
Iout	mA	300	350	400	450	500	550	600	650	700	750	800	850	900	950	1000	1050
Vout	Vdc	10-42	10-42	10-42	10-42	10-42	10-42	10-42	10-42	10-42	10-42	10-42	10-40	10-40	10-40	10-40	10-40
Power	W	13	15	17	19	21	23	25	27	29	32	34	34	36	38	40	42
N° LED typical VF 3,2V	min max	3÷13	3÷13	3÷13	3÷13	3÷13	3÷13	3÷13	3÷13	3÷13	3÷13	3÷13	3÷12	3÷12	3÷12	3÷12	3÷12

COB - Typical VF 37V

U-Boot è il nuovo driver led per binario elettrificato, che annega nel binario stesso lasciando a vista solo la lampada, creando così un'estetica lineare e simmetrica. Fornito di dip-switch per la selezione della corrente in uscita.

U-Boot is the new LED driver for electrified track installation, which is embedded in the track itself, leaving only the lamp visible, resulting in a linear and symmetrical design. Equipped with dip-switch for selecting the output current.

### Norme di riferimento - Reference norms

EN 55015; EN 61000-3-2  
EN 61000-3-3; EN 61347-1  
EN 61347-2-13; EN 61547; EN62384

### Esempio applicativo - Application example





# JOLLY 55 DALI 2 - PUSH - 0-10V CC

Alimentatore elettronico multipotenza DIM - LED Driver multipower DIM

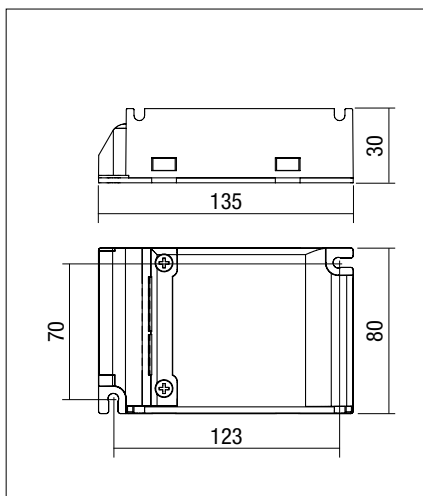

### Norme di riferimento Reference norms

- EN 55015
- EN 61000-3-2
- EN 61000-3-3
- EN 61347-1
- EN 61347-2-13
- EN 61547
- EN62384
- VDE 0710-T14

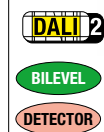

Codice Code	LPH ↓mm	Vdc IN	DIM	Vac IN	DIM	Hz	W	TOTAL?	iC	Vout Vdc	ta °C	tc °C	PFC	PCS	CCM cm³
RN9168DAPU010	135x80x30	176-264	DALI 2 S10	220-240	DALI 2 P S10	50/60	55	15	25A 200µS	65	-20...45	80	OK	10	7.546

I out	mA	400	500	600	700	800	900	1000	1100	1200	1300	1400	1500	1600	1700	1800	1900
Vout	Vdc	45	45	45	45	45	45	45	45	45	42	39	37	34	32	31	29
Max Power	W	18	22	27	31	36	40	45	50	55	55	55	55	55	55	55	55
N° LED typical VF 3,2V	Min - Max	1÷14	1÷14	1÷14	1÷14	1÷14	1÷14	1÷14	1÷14	1÷14	1÷13	1÷12	1÷11	1÷10	1÷10	1÷9	1÷9
<b>COB - Typical VF 37V</b>																	

### Caratteristiche tecniche

- Alimentatore multipotenza fornito di dip-switch per la selezione della corrente in uscita
- Alimentatore indipendente IP20, per uso interno
- Protetto in classe II contro le scosse elettriche per contatti diretti e indiretti
- Uscita in corrente costante (CDT)
- Protezioni: al cortocircuito, contro le extra-tensioni di rete, contro i sovraccarichi.
- Morsetti di entrata e uscita sullo stesso lato
- Non è possibile l'accensione e lo spegnimento sul secondario
- CDT connessione moduli led in serie

### Sistemi di regolazione

**DALI 2** = protocollo DALI 2

**S10** = tramite segnale di controllo 0-10Vdc

**R** = tramite dimmer serie DIM34 (Relco)

**P** = tramite pulsante NA (non fornito)

**BILEVEL**

### Technical features

- Multi-power power supply equipped with dip-switch for selecting the output current
- Independent IP20 power supply, for internal use
- Class II protection against electric shocks for direct and indirect contacts
- Constant current output (CDT)
- Protections: against short circuit, against extra-voltage mains, against overloads.
- Input and output terminals on the same side
- Switching on and off on the secondary is not possible
- CDT connection of LED modules in series

### Regulation systems

**DALI 2** = DALI 2 protocol

**S10** = via 0-10Vdc control signal

**R** = via DIM34 series dimmer (Relco)

**P** = via NA button (not supplied)

**BILEVEL**

# LIMITATORE DI SOVRATENSIONE - SURGE PROTECTOR

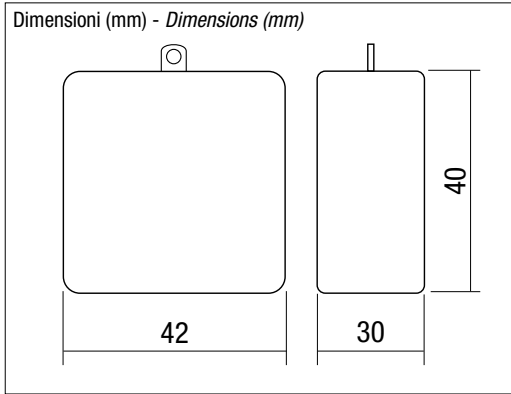

In un impianto elettrico standard un apparecchio a LED può essere sottoposto a sbalzi di tensione e disturbi esterni dovuti a fattori quali carichi discontinui sulla linea, guasti sulle linee a monte o a valle e, soprattutto, scariche atmosferiche (negli impianti esterni). Nei nostri proiettori, dove l'elettronica è fondamentale, la resistenza alle sovratensioni è sinonimo di affidabilità e corretta funzionalità.

In a standard electrical system an LED luminaire can be subjected to voltage fluctuations and external disturbances due to factors such as discontinuous loads on the line, faults on the lines upstream or downstream and, especially, atmospheric discharges (in External Plants). In our projectors, where electronics is very important, the surge resistance is synonymous with reliability and proper functionality.

## IEEE C62.41 - Forme d'onda di corrente / tensione per varie località di esposizione - Current/Voltage waveforms for various exposure locations

Codice Code	Categoria Category	Livello Level	Tensione Voltage (kV)	1,2 x 50 $\mu$ s <sup>S</sup> (V) - 8 x 20 $\mu$ s <sup>S</sup> (A) Combination wave - Current (A)	PCS 	CcM cm <sup>2</sup>
R00640/N	C2	Medio - Medium	10	5	5	6.210

Categoria - Category	Livello - Level	Tensione - Voltage (kV)	0,5 $\mu$ s <sup>S</sup> x 100kHz Ring wave - Current (A)	1,2 x 50 $\mu$ s <sup>S</sup> (V) - 8 x 20 $\mu$ s <sup>S</sup> (A) Combination wave - Current (A)
A1	Basso - Low	2	701	
A2	Medio - Medium	3	130	
A3	Alto - High	6	200	
B1	Basso - Low	2	170	1
B2	Medio - Medium	4	330	2
B3	Alto - High	6	500	3
C1	Basso - Low	6		3
C2 ●	Medio - Medium	10		5
C3	Alto - High	20		10

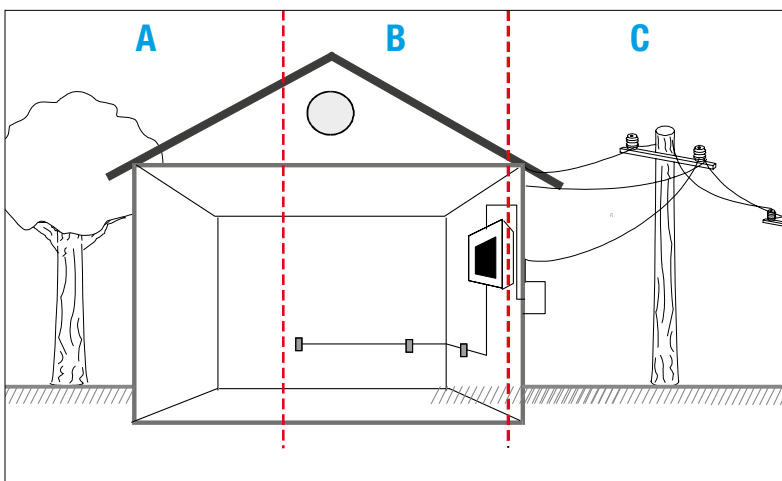

- A**  
**Categoria A - Category A**
- Tutti i punti a più di 10 metri dalla categoria B
  - Tutti i punti a più di 20 metri dalla categoria C
  - All outlets at more than 10m from Category B
  - All outlets at more than 20m from Category C

- B**  
**Categoria B - Category B**
- Dispositivi del pannello di distribuzione
  - Distribuzione Bus e alimentazione
  - Prese per le apparecchiature interne
  - Sistemi di illuminazione in grandi edifici
  - Distribution panel devices
  - Bus and feeder distribution
  - Heavy appliance outlets with "short" connections to service entrance
  - Lighting systems in large buildings

- C**  
**Categoria C - Category C**
- Linea di servizio dalla rete elettrica
  - Collegamento tra centrale e quadro elettrico
  - Linee aeree a edificio indipendente
  - Sistemi di illuminazione in grandi edifici
  - Service drops from pole to building
  - Runs between meter and panel
  - Overhead lines to detached building
  - Lighting systems in large buildings

# LINEAR INVERLED 1 o 3W - 145V - SA-SE

**AUTOTEST**

**NO AUTOTEST**

Inverter di emergenza LED a potenza costante - *Constant power LED inverter*



Batteria separata  
Separate battery



Dimensioni (mm) - Dimensions (mm)

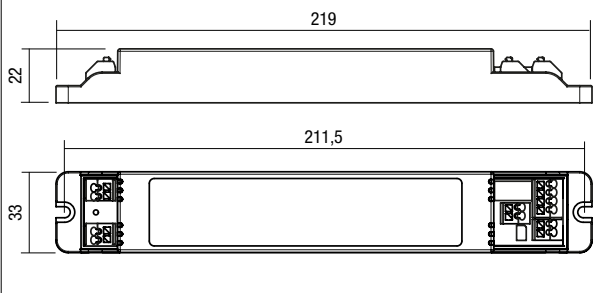

Conforme alle seguenti Norme  
In Compliance with the following Standards

EN61347-2-13	EN55015
EN61347-2-7	EN60598-2-22
EN61547	EN61000-3-2

● (3W : lamp power) x 100 - ● (1W : lamp power) x 100

Article	V Hz	Supply current mA	I out mA	V out min	V out max	W max	Autonomy (h)	Flux %	ta °C	PCS	Codice Code	
LINEAR INVERLED OB 3W - 145V - SA-SE	220-240V - 50/60Hz	50	21-200	15	145	3	3	●	5...45	6	RP0714NOAUT	<b>NO AUTOTEST</b>
LINEAR INVERLED OB 3W - 145V - SA-SE	220-240V - 50/60Hz	50	21-200	15	145	3	3	●	5...45	6	RP0714	<b>AUTOTEST</b>
LINEAR INVERLED OB 1W - 145V - SA-SE	220-240V - 50/60Hz	50	5-46	15	145	1	3	●	5...45	6	RP0718	<b>AUTOTEST</b>

Batterie non incluse - Not included batteries Norme / Standard: IEC62133 - IEC60598-2-22:2014

Cod. 00PB0530-N  
Per RP0714 - RP0714NOAUT  
For RP0714- RP0714NOAUT  
- LiFePO4  
- 3.2V - 6A/h  
- Tempo di ricarica: max 24h  
Charging time: max 24h

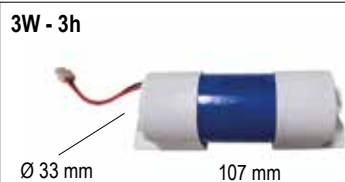

Cod. 00PB1500  
Per RP0718 - For RP0718  
- 4.80Wh/LiFePO4 - 3,2V - 1.5Ah  
- Tempo di ricarica: max 24h  
Charging time: max 24h



Cod. 00PB065050  
Per RP0714 - RP0714NOAUT  
For RP0714- RP0714NOAUT  
- LiFePO4  
- 3.2V - 6A/h  
- Tempo di ricarica: max 24h  
Charging time: max 24h



Sistema di emergenza per faretto LED a potenza costante con batteria LiFePO4

Sono possibili due modalità di funzionamento:

**SA:** Funzionamento permanente. Il faretto LED in questa configurazione funzionerà normalmente con comando ON/OFF dedicato e in caso di blackout entrerà in modalità emergenza (FIG. 3). Batteria non inclusa

**SE:** Funzionamento non permanente. Il faretto LED sarà sempre spento e si accenderà solo in caso di blackout (Fig. 4).

Per il funzionamento in modalità SA, Linear Inverled 3W, oltre alla batteria (non inclusa), dovrà anche essere collegato ad un driver a corrente costante. Il driver a corrente costante non è incluso.

**Principali caratteristiche tecniche:**

- Autotest conforme alla IEC 62034 (stato della batteria, test di funzionamento, test durata batteria)
- Rest mode
- Protezione al sovraccarico
- Flusso costante in emergenza
- Non necessita di selezione della tensione di uscita
- Fornisce sempre una potenza costante (3W - Cod. RP0714NOAUT - RP0714 - RP0718,) qualunque sia la tensione del carico, nel range di tensione di uscita 15-145V.
- Circuito di protezione della batteria contro la scarica prolungata.
- LED Rosso/Verde indicante lo stato dell'Inverter (vedi tabella). Lunghezza standard del cavo 600mm
- Disaccoppiamento tramite relè
- Relè di ingresso (linea di alimentazione del driver)
- Morsetti ad innesto rapido su linea permanente, linea driver, uscita e di inibizione
- Inibizione tramite controllore opzionale (Cod. DALI-PS-DIN)
- Pulsante di test opzionale (Cod. 24500700)
- Sezione cavi di ingresso da 0,5 a 1,5 mm<sup>2</sup>
- Sezione cavi di uscita da 0,5 a 1,5 mm<sup>2</sup>
- Tempo di intervento <= 800msec
- Foro di fissaggio del LED: Ø 9mm

**Emergency system for constant power LED Spotlight with LiFePO4 battery**

There are 2 possible operating modes:

**SA:** Permanent operation. The LED spotlight in this configuration will normally work with a dedicated ON / OFF command and in the event of a blackout it will go into emergency mode (FIG. 3). Battery not included

**SE:** Non-permanent operation. The LED spotlight will always be off and will turn on only in the event of a blackout (Fig. 4).

For permanent operation, the Linear Inverled 3W must be connected to the spotlight's constant current driver and the LiFePO4 battery. The constant current driver is not included.

**Technical characteristics**

- Self-test according to IEC 62034 (battery status, function test, battery life test)
- Rest mode
- Overload protection
- Constant flow in an emergency
- Does not need to select the output voltage
- Always supplies a constant power (3W - Cod. RP0714NOAUT - RP0714 - RP0718,) whatever the load voltage, in the 15-145V output voltage range
- Battery protection circuit against prolonged discharge.
- Red / Green LED indicating the inverter status (see table). Standard cable length 600mm
- Decoupling via relay
- Input Relay (Driver Power Line)
- Inhibition via optional controller (Cod. DALI-PS-DIN)
- Optional test button (Cod. 24500700)
- Cables from 0,75 to 1,5mm<sup>2</sup> (input side)
- Cable from 0,75 to 1mm<sup>2</sup> (output side)
- Intervention time <= 800msec
- LED fixing hole: Ø 9mm

# LINEAR INVERLED 1 o 3W - 145V - SA-SE AUTOTEST

## Inverter di emergenza LED a potenza costante - *Constant power LED inverter*

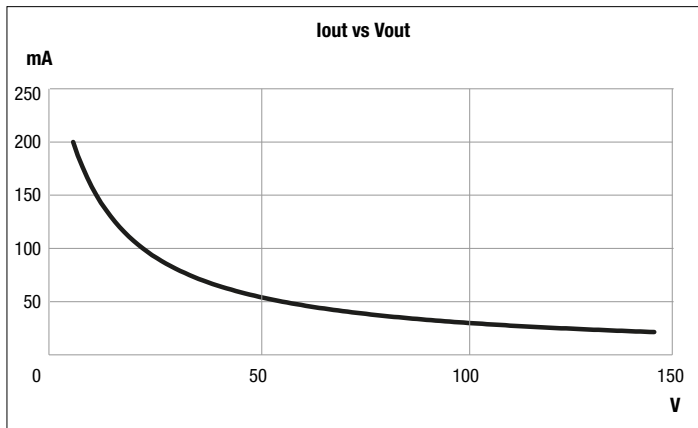

**Fig. 1**  
**RP0714**  
Caratteristica tensione / corrente - *Output characteristic voltage / current*

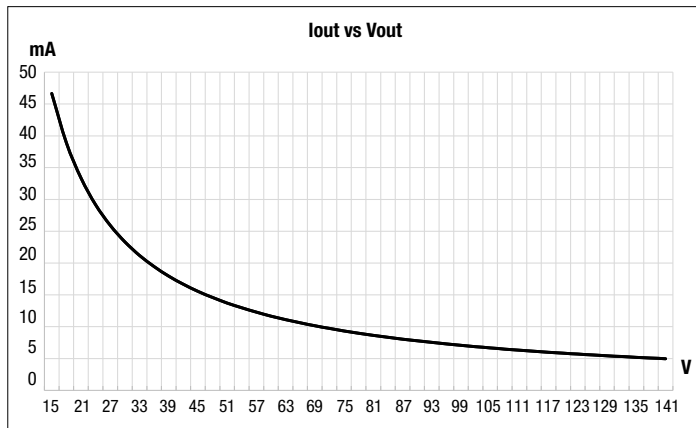

**Fig. 2**  
**RP0718:** Caratteristica tensione / corrente - *Output characteristic voltage / current*

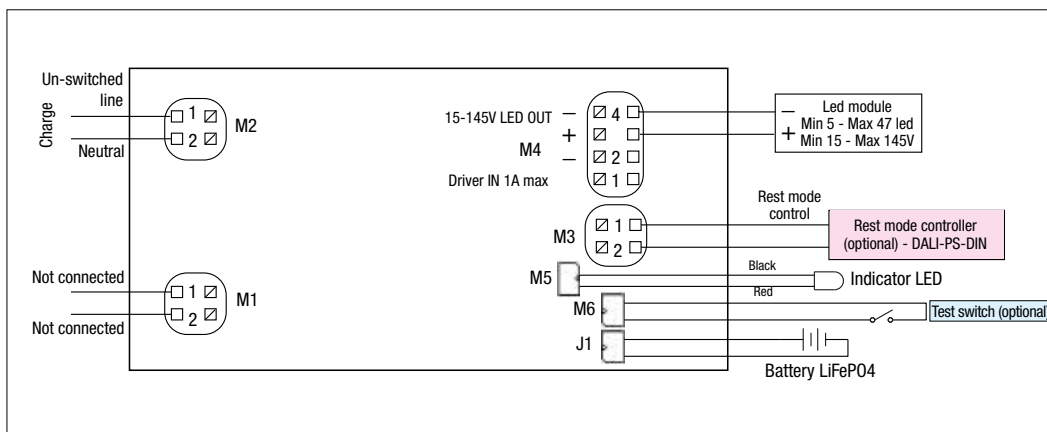
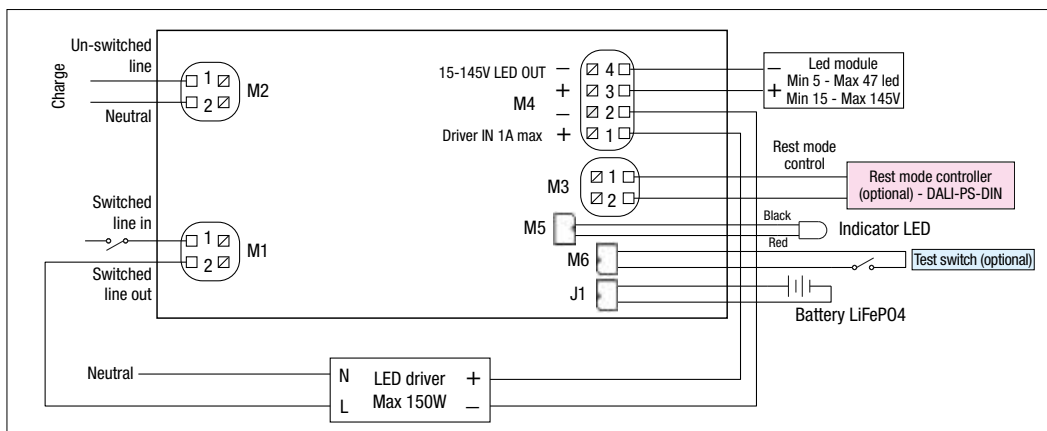

### Accessori non inclusi - *Not included accessories*



Cod. DALI-PS-DIN

N° modul	W	Vac	Hz	V out - Vdc	I out - Vac	Ta °C
2	3	100-240	50/60	15	200mA	-30...55

**Alimentatore (guida DIN)**  
Protezione al cortocircuito e sovratemperatura, con ripristino automatico.  
Raffreddamento ad aria naturale.  
Custodia in plastica.  
Alimentatore di classe 2.  
Conforme allo standard di sicurezza a bassissima tensione  
Adatto ad ambienti interni.

**Power Supply (DIN Rail)**  
*Short circuit / Over-temperature protection, auto recovery.*  
*Natural air cooling.*  
*Full protective plastic housing.*  
*Class 2 power supply.*  
*Compliant with Safety Extra Low Voltage standard*  
*Suitable for indoor environments.*



Cod. 24500700  
Pulsante di test - *Test push button*

# LINEAR INVERLED 1 o 3W - 145V - SA-SE **AUTOTEST**

## Inverter di emergenza LED a potenza costante - *Constant power LED inverter*

Tabella stato di funzionamento - <i>Operating status table</i>		
Colore LED - <i>LED indication</i>	Stato - <i>Status</i>	Descrizione - <i>Description</i>
● VERDE fisso - Permanent GREEN	Sistema OK - System OK	Batteria carica o in carica - <i>Battery charge</i>
● VERDE lampeggiante - <i>Flashing GREEN</i>	Funzione TEST avviata - <i>Function TEST underway</i>	/
● VERDE lampeggiante lento (1s ON - 1s OFF) <i>Slow flashing GREEN (1s ON - 1s OFF)</i>	TEST di durata avviato - <i>Duration TEST underway</i>	/
● VERDE doppio lampeggio <i>Double pulsing GREEN</i>	Modalità di inibizione attivata <i>Inhibit mode is activated</i>	La modalità di inibizione consente di impostare la modalità di emergenza su "inibita", in questa modalità è possibile spegnere l'alimentazione senza passare alla modalità di emergenza. La modalità di inibizione viene attivata inviando il segnale di inibizione, mentre i moduli sono ancora collegati alla rete. Proprio come in modalità di riposo, il dispositivo supporta la funzione di riaccensione. Dopo una pausa di 15 minuti, la modalità di inibizione viene ripristinata automaticamente. <i>The inhibit mode makes it possible to set the emergency mode to "inhibited", in this mode, the power can be turned off without switching to emergency mode. The inhibit mode is activated by sending the inhibit signal, while the modules are still connected to mains. Just as in Rest Mode, the device support the reight function. after a break of 15 minutes, the inhibit mode is automatically reset.</i>
● ROSSO fisso <i>Permanent RED</i>	Lampada guasta <i>Lamp failure</i>	Circuito aperto - Corto circuito - LED guasto. Dopo una sostituzione del modulo LED, il LED di segnalazione rimane ROSSO fisso. L'indicazione di guasto lampada rimarrà impostata fino a quando non sarà stato fatto un test funzionale completato con successo. Il test si potrà eseguire: automaticamente con il test funzionale settimanale, immediatamente interrompendo brevemente l'alimentazione oppure avviando manualmente con un interruttore di test. Il funzionamento da rete del modulo LED non ripristina l'indicatore di guasto della lampada. <i>Open circuit -or- Short circuit -or- LED failure After an exchange of the LED module, the indicator LED remains permanent RED. The lamp failure indication remains set until a function test has been successfully completed (automatically with the weekly function test or immediately by briefly interrupting the power supply or by manually starting the function test with a test switch. The LED module's mains operation does not reset the Imp failure indication.</i>
● ROSSO lampeggio veloce (0,1s ON - 0,1s OFF) <i>Fast flashing RED (0,1s ON - 0,1s OFF)</i>	Errore di ricarica <i>Charging failure</i>	Corrente di ricarica errata. Quando la batteria è in modalità di carica di mantenimento e l'alimentazione di rete è collegata, il microcontrollore interno, monitora i parametri di carica. Se viene rilevato un errore o un parametro è fuori tolleranza, il LED indicatore diventa ROSSO lampeggiante veloce. Se l'errore è stato corretto, il LED di segnalazione torna immediatamente a VERDE e continua l'operazione di carica della batteria. <i>Incorrect charging current. While the battery is in trickle charge mode and mains supply is connected, the micro controller in the emergency unit monitors the charging parameters. If an error is detected or a parameters is out of tolerance, the indicator LED switches to fast flashing RED. If the error has been corrected, the indicator LED immediately switches back to GREEN and continues the charging operation of the battery.</i>
● ROSSO lampeggio lento (1s ON - 1s OFF) <i>Slow flashing RED (1s ON - 1s OFF)</i>	Batteria guasta <i>Battery failure</i>	Test di durata della batteria o test di funzionamento fallito, Batteria difettosa, Tensione della batteria non corretta.  Test di durata della batteria o test di funzionamento fallito: se la batteria non raggiunge la piena durata di funzionamento, il LED ROSSO lampeggia lentamente. Dopo una sostituzione della batteria il LED di segnalazione diventa VERDE. Per garantire un'autonomia di funzionamento soddisfacente, la batteria viene quindi caricata per 20 ore e viene eseguito un secondo test di autonomia.  La batteria è difettosa o la tensione non è corretta: mentre la batteria è in modalità di carica e l'alimentazione di rete è collegata, il microcontrollore monitora le condizioni della batteria. Se viene rilevato un errore, il LED indicatore diventa ROSSO. Se l'errore è stato corretto, il LED di segnalazione torna immediatamente a VERDE e continua l'operazione di carica della batteria.  <i>Battery failed duration test or function test -or- Battery is defect -or- Incorrect battery voltage.</i>  <i>Battery failed duration test or function test: If the battery does not reach full operating time indicator LED is slow flashing RED. After an exchange of the battery the indicator LED switches to GREEN. To a guarantee a satisfactory operating time, the battery is then charged for 20 hours and a second duration test is carried out.</i>  <i>Battery is defect or incorrect voltage: While the battery is in trickle charge mode and the mains supply is connected, the microcontroller in the emergency unit monitors the condition of the battery. If an error is detected, the indicator LED switches to RED. If the error has benn corrected, the indicator LED immediately switches back to GREEN and continues the charging operation of the battery.</i>
● VERDE e ROSSO off GREEN and RED off	Funzionamento batteria <i>Battery operation</i>	Modalità di emergenza: rete scollegata, mancanza di rete <i>Emergency mode: Mains disconnected -or- mains failure</i>

# LINEAR INVERLED OB - 5W/160V - SA-SE

## Inverter di emergenza LED a potenza costante - *Constant power LED inverter*



Batteria separata  
Separate battery



Sistema di emergenza per faretto LED a potenza costante con batteria NiCd a scelta, in funzione dell'autonomia desiderata

Sono possibili due modalità di funzionamento:

**SA:** Funzionamento permanente. Il faretto LED in questa configurazione rimane acceso in caso di interruzione di corrente

**SE:** Funzionamento non permanente. Il faretto LED si accende solo in caso di interruzione della corrente. Il dispositivo adattata automaticamente la tensione al carico collegato entro i limiti stabiliti nella tabella.

Per il funzionamento in modalità permanente Linear Inverled OB deve essere collegato ad un driver a corrente costante e alla batteria NiCd. Il driver a corrente costante non è incluso.

**Principali caratteristiche tecniche:**

- Compatto
- Batteria da ordinare a parte in base all'autonomia
- Flusso costante in emergenza
- Non necessita di selezione della tensione di uscita
- Fornisce sempre una potenza costante (3W) qualunque sia la tensione del carico, nel range di tensione di uscita 12-90V (5W) qualunque sia la tensione del carico, nel range di tensione di uscita 12-160V.
- Circuito di protezione della batteria contro la scarica prolungata.
- LED verde indicante il collegamento alla rete di alimentazione (lunghezza standard del cavo, 600mm)
- Disaccoppiamento in uscita tramite relè
- Morsetti di collegamento alla linea permanente e di inibizione a cablaggio automatico
- Inibizione tramite interruttore
- Sezione cavi di ingresso da 0,75 a 1,5 mm<sup>2</sup>
- Sezione cavi di uscita da 0,75 a 1 mm<sup>2</sup>
- Tempo di intervento <= 800msec
- Tempo di ricarica: 24h per batteria Cod. 00PB0100 (3W).
- Tempo di ricarica: 24h per batteria Cod. 00PB0800 (5W).
- Foro di fissaggio del LED: Ø 9mm

Dimensioni (mm) - Dimensions (mm)

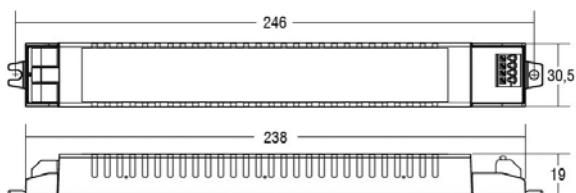

**Emergency system for constant power LED Spotlight with NiCd battery of your choice depending on the autonomy**

**There are 2 possible operating modes:**

**SA:** Permanent operation. The Led Spotlight in this configuration remains on in the event of a power outage. It needs an Led driver (not included) sized according to the power of the spotlight.

**SE:** Non-permanent operation. The Led spotlight comes on only when there is a power outage. It does not require a driver. The device automatically adapt its output within the limits st in the cart.

For permanent operation, the Linear Inverled OB must be connected to the spotlight's constant current driver and the NiCd battery. The constant current driver is not included.

- Compact
- Battery to order separately depending on the necessary autonomy
- Constant flow in an emergency
- Does not need to select the output voltage
- Always supplies a constant power (3W) whatever the load voltage, in the 12-90V output voltage range
- Always supplies a constant power (5W) whatever the load voltage, in the 12-160V output voltage range
- Battery protection circuit against prolonged discharge.
- Green Led indicating the connection to the mains supply (standard cable lenght, 600mA)
- Output decoupling via relay
- Automatic connection terminals
- Inhibition via a switch
- Cables from 0,75 to 1,5mm<sup>2</sup> (input side) - Cable from 0,75 to 1mm<sup>2</sup> (output side)
- Intervention time <= 800msec
- Charging time: 24h for battery Cod. 00PB0100 (3W).
- Charging time: 24h for battery Cod. 00PB0800 (5W).
- LED fixing hole: Ø 9mm

Conforme alle seguenti Norme  
In Compliance with the following Standards

EN61347-2-13	EN55015
EN61347-2-7	EN60598-2-22
EN61547	EN61000-3-2

Article	V Hz	Supply current mA	I out mA	V out min	V out max	W max	Flux %	ta °C	Codice Code
LINEAR INVERLED OB 5W - 160V - SA-SE	220-240V - 50/60Hz	10	30 - 250	12	160	5	3	0...40	RP0715

● (lamp power) x 100

### Batterie non include - *Not included batteries*

**Cod. 00PB0800**

- 6 elementi - 6 elements
- Nickel Cadmium
- 2x3,6V - 4A/h Battery
- Tempo di ricarica: max 24h  
Charging time: max 24h
- Ø 33 x L 360 mm
- Dimensioni singola batteria  
Single battery dimensions

Conforme alle Norme  
Standard  
IEC62133  
IEC60598-2-22:2014

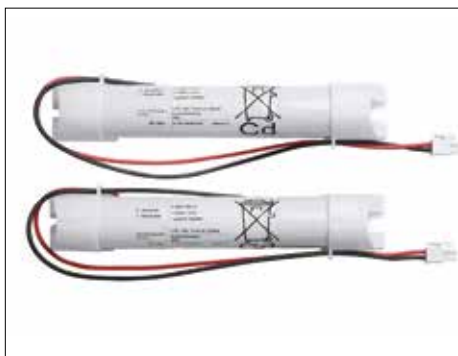

# LINEAR INVERLED OB - 5W/160V - SA-SE

## Inverter di emergenza LED a potenza costante - *Constant power LED inverter*

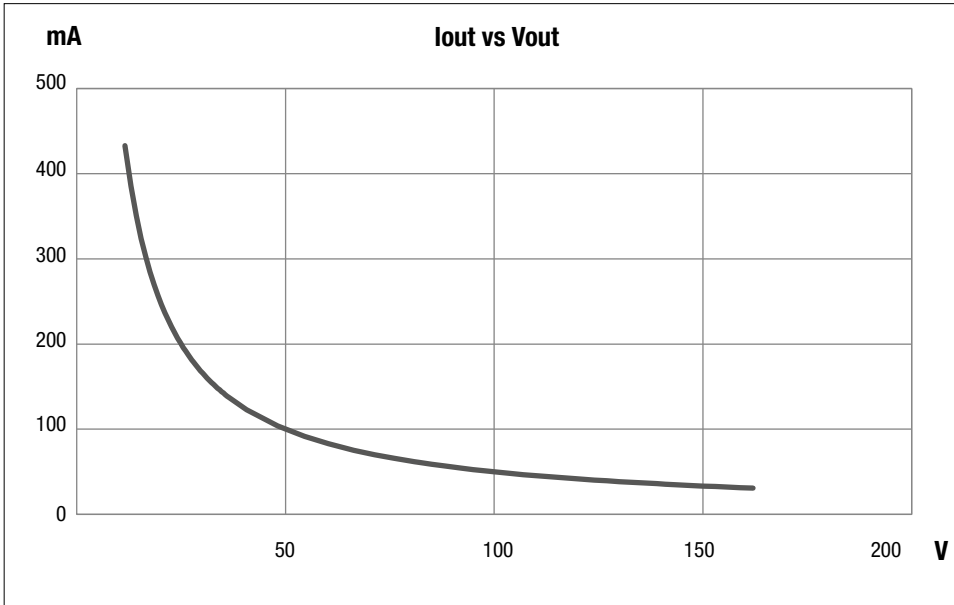

**Fig. 1**  
Caratteristica tensione / corrente  
*Output characteristic voltage / current*

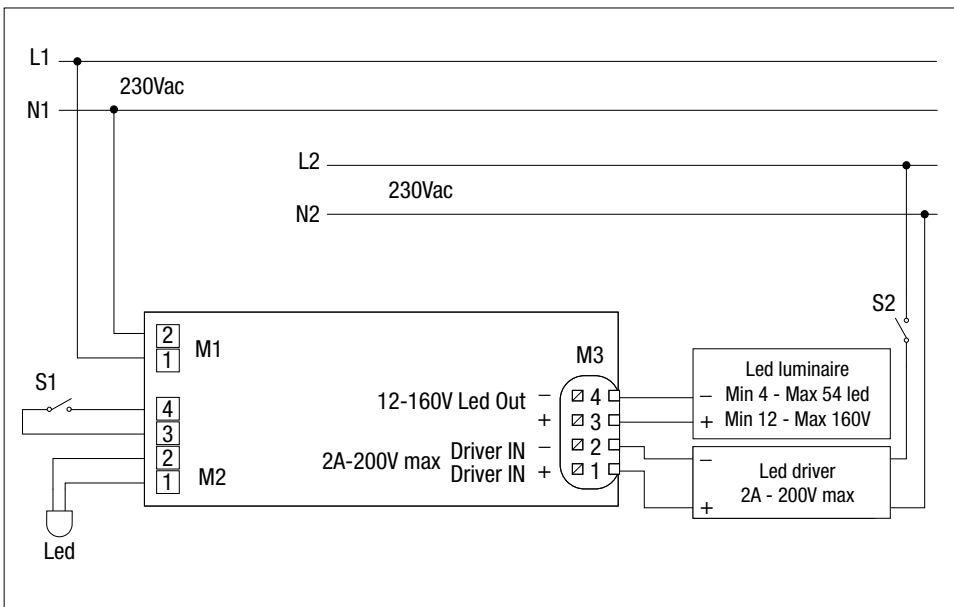

**Fig. 2**  
Schema di collegamento SA (Sempre Accesa)  
*Wiring diagram SA (Always on)*

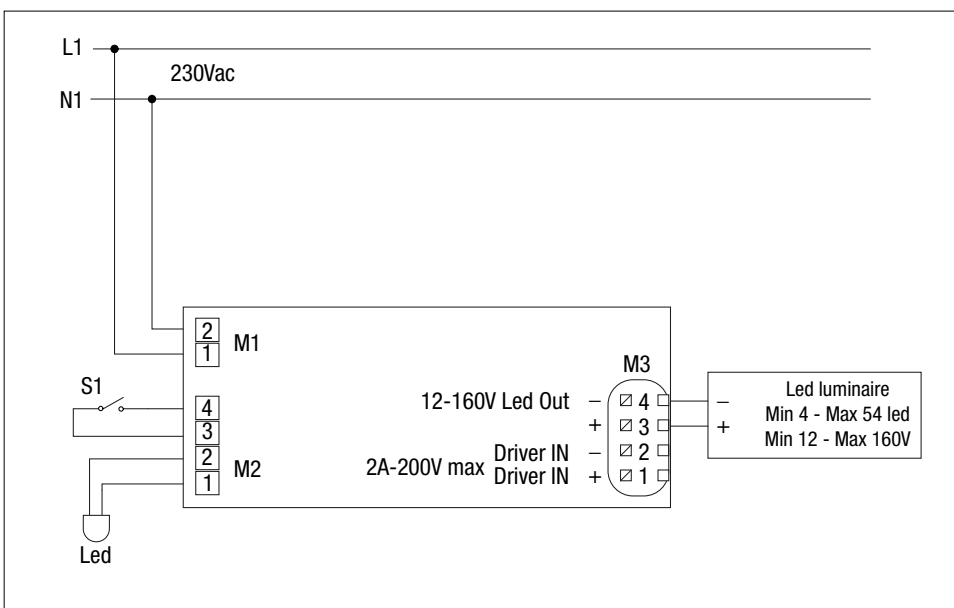

**Fig. 3**  
Schema di collegamento SE (Solo Emergenza)  
*Wiring diagram SE (Only Emergency)*

# LINEAR INVERLED DALI 2 1,8W - 300V - SA-SE

**AUTOTEST**

Inverter di emergenza LED a potenza costante - *Constant power LED inverter*



- Emergenza per moduli LED con interfaccia DALI e funzione di test automatico
- Per moduli LED con tensione continua 50-300Vdc
- Batteria al litio ferro fosfato LiFePO4 plug-in (inclusa)
- 2 anni di garanzia elettronica
- 4 anni di garanzia sulla batteria
- Funzionamento SA/SE
- Alimentazione bus DALI integrata
- Spegnimento automatico dell'uscita se il carico LED è fuori range
- Potenza costante, corrente di uscita autoregolante
- Sistema di carica elettronico
- Protezione della batteria da scarica profonda
- Collegamento della batteria a prova di cortocircuito
- Protezione dal carico scollegato o in cortocircuito
- Protezione contro l'inversione di polarità della batteria
- LED Emergency driver with DALI interface and automatic test function
- For LED module with a forward voltage of 50-300Vdc
- Plug-in Lithium Iron Phosphate battery LiFePO4 (Included)
- 2 years guarantee electronic
- 4 years guarantee battery
- Maintained/Non-maintained operation
- Integrated DALI bus power supply
- Automatic shutdown of output if LED load is out of range
- Constant power output, output current self-adjustable
- Electronic charge system
- Deep discharge protection
- Short-circuit-proof battery connection
- Open-circuit-proof / short circuit
- Polarity reversal protection for battery

Dimensioni (mm) - Dimensions (mm)

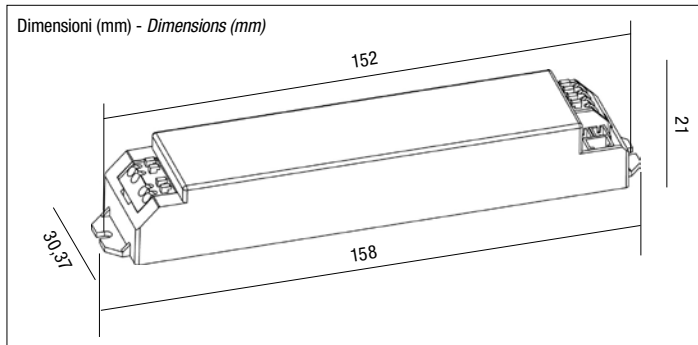

Conforme alle seguenti Norme  
In Compliance with the following Standards

EN61347-2-13	EN55015
EN61347-2-7	EN60598-2-22
EN61547	EN61000-3-2
EN62386	

Article	V Hz	Supply current mA max	I out mA max-min	V out min	V out max	W max	Autonomy (h)	Flux %	ta °C	PCS	Code Code
LINEAR INVERLED DALI 1,8W - 300V - SA-SE	220-240V - 50/60Hz	25	120-6	15	300	1,8	3	●	0...55	6	REEC15H-DL

● (1,8W : lamp power) x 100

1 - Tutte le specifiche sono tipiche per alimentazione 230 V CA, salvo diversa indicazione - All specifications are typical on the 230VAC unless otherwise stated

2 - Il test di funzionamento in emergenza deve essere eseguito quando una batteria è completamente carica per 16/24 ore

The emergency function test must be performed when a battery is fully charged for 16/24 hours

# LINEAR INVERLED 1,8W - 300V - SA-SE

**AUTOTEST**

## Inverter di emergenza LED a potenza costante - *Constant power LED inverter*

### Schema di collegamento - Wiring diagram

La massima tensione a vuoto è 300V - The maximum no-load voltage of the drive is 300V

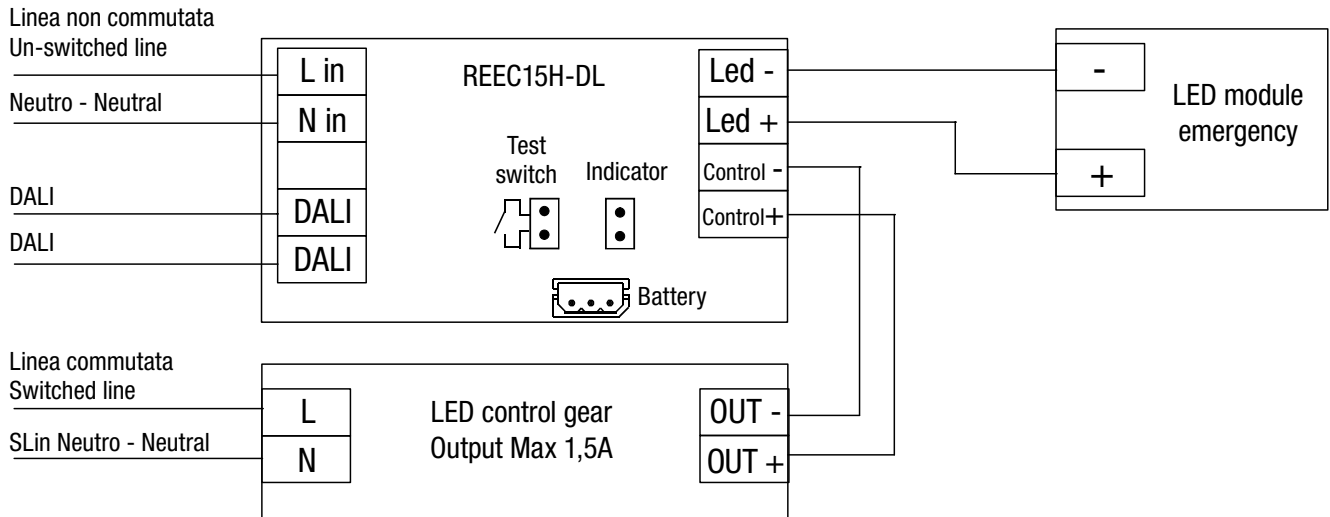

- 1 - In caso di blackout, condizione in cui l'indicatore LED risulterà spento, il modulo LED va in emergenza
- 2 - La batteria deve essere ricollegata dopo essere stata scollegata con rete presente (Attenzione: in tal caso scollegare la rete e ricollegarla)
- 3 - Il driver Led applicabile deve essere isolato. La massima tensione di uscita non può essere superiori a 300V, la massima corrente non può superare 1,5 A.
- 4 - Quando lo SLin è collegato il modulo LED è acceso.  
Quando SLin è disconnesso il modulo LED è spento.

- 1 - Mains power off, the light goes into emergency mode
- 2 - Battery be connected again after disconnected when mains power on (Attention: In that case, please re-set the AC mains power)
- 3 - The applicable Led driver should be isolated, and max. voltage can not over 300V, max. current can not over 1.5A.
- 4 - When the SLin is connected, the LED light is maintained. When SLin is disconnected, the LED lights is non maintained.

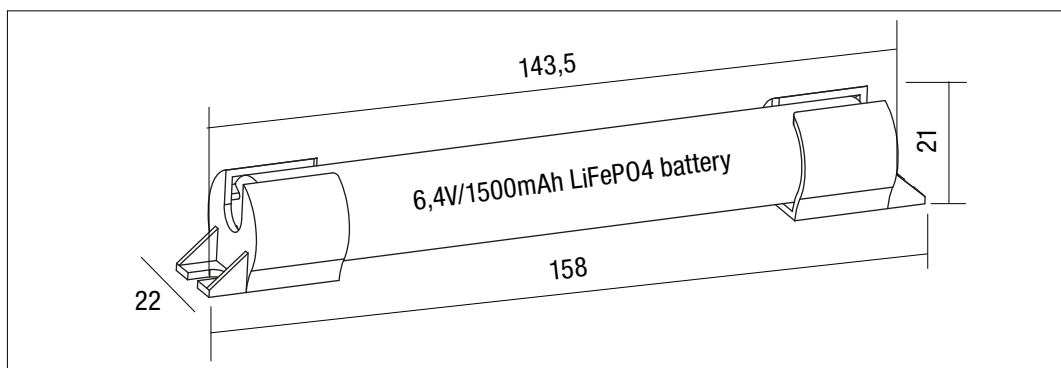

# LINEAR INVERLED 1,8W - 300V - SA-SE

**AUTOTEST**

## Inverter di emergenza LED a potenza costante - *Constant power LED inverter*

### Batteria - Battery

- Celle della batteria ad alta temperatura - High temperature grade battery cells
- Batteria 6,4V LiFePO4 - 6,4V LiFePO4 battery
- Presa maschio/femmina per un collegamento semplice - Male/female socket for simple connection

### Batteria LiFePO4 - LiFePO4 battery

- Intervallo di temperatura della custodia per garantire 4 anni di durata del progetto: 0°..60°C  
Case temperature range to ensure 4 years design life: 0°..60°C
- Volt batteria - Battery voltage: 3,2V per cell
- Capacità 18650 - 1500mAh - Capacity: 18650 - 1500mAh

### Indicazione di stato LED verde

#### Status indication Green LED

- Un LED verde indica che la corrente di carica scorre nella batteria  
A green LED indicates that charging current is flowing into the battery
- Collegamento a spina 1  
Plug connection 1



### Test switch

- Per il collegamento all'unità di illuminazione di emergenza  
For connection to the emergency lighting unit
- Per controllare il funzionamento del dispositivo  
For checking the device function
- Plug connection  
Collegamento a spina



### Testing / commission (DALI)

REEC15H\_DL serie DALI è conforme ai protocolli standard IEC62386-102 e IEC 62386-202(DT1). È perfettamente compatibile con il sistema di controllo DALI di Tridonic, Osram, Philips e altri famosi marchi internazionali.

- 1 - Sono presenti una varietà di funzioni della modalità di lavoro, modalità normale, modalità di emergenza, modalità di riposo, modalità di inibizione, modalità di test di funzione e modalità di test di durata
- 2 - L'intervallo di tempo del test funzionale e l'intervallo di tempo del test di durata possono essere impostati e letti per personalizzare la funzione di test automatico.
- 3 - Registrazione e lettura automatica dell'orario di lavoro e di emergenza della serie REEC15H-DL
- 4 - Varie letture dello stato normale e di emergenza

### Controllo DALI

- 1 - Un comando DALI da un'unità di controllo idonea può essere utilizzato per avviare test di funzionamento e autonomia in orari selezionati individualmente I flag di stato vengono impostati per la segnalazione e la registrazione dei dati dei risultati.
- 2 - Quando non è stato collegato un bus DALI o quando è collegato un bus DALI ma i tempi di DELAY e INTERVAL non sono stati quindi reimpostati inviando opportuni comandi DALI il REEC15H-DL eseguirà i test in conformità con i tempi predefiniti impostati all'interno del REEC15H-DL.
- 3 - Questi tempi predefiniti sono preimpostati in fabbrica, in conformità con lo standard DALI EN 62386-202, per eseguire un test di funzionamento automatico ogni 7 giorni e un test di autonomia ogni 180 giorni. Poiché il tempo di RITARDO è preimpostato in fabbrica su Zero, tutte le unità vengono testate contemporaneamente. I tempi di prova possono essere modificati con un comando sul bus DALI.

### Testing / commission (DALI)

REEC15H-DL DALI series conform IEC62386-102 and IEC 62386-202(DT1) standard protocol. It is perfectly compatible with DALI control system of Tridonic, Osram, Philips and other famous international brands.

- 1 - With a variety of working mode switching functions, normal mode, emergency mode, rest mode, inhibit mode function test mode and duration test mode
- 2 - Functional test time interval and duration test time interval can be set and read to achieve automatic test function
- 3 - Automatic recording and reading of REEC15H-DL series working time and emergency time
- 4 - Various normal and emergency status reads

### DALI control

- 1 - A DALI command from a suitable control unit can be used to initiate function and duration tests at individually selected times Status flags are set for report back and data logging of results.
- 2 - When a DALI bus has not been connected or when a DALI bus is connected but the DALI default DELAY and INTERVAL times have not been re-set by sending appropriate DALI commands, then the REEC15H-DL will conduct self-tests in accordance with the default times set within the REEC15H-DL.
- 3 - These default times are factory pre-set, in accordance with the DALI standard EN 62386-202, to conduct an automatic function test every 7 days and a duration test every 180 days. Since the DELAY time is factory pre-set to Zero, all units are tested at the same time. Test times can be changed with a command over the DALI bus.

LED-Anzeige Lokaler Systemstatus durch eine zweifarbige LED-Anzeige		
LED-Anzeige	Zustand	Beschreibung
Dauerhaft grün	Standby, System OK	Netzbetrieb vorhanden und/oder Batterieladung
Schnelles grünes Blinken (0,25 s ein, 0,25 s aus)	Funktionstest im Gange	Funktionstest läuft
Langsames grünes Blinken (1s ein, 1s aus)	Test di durata in corso	Haltbarkeitstest läuft
Permanentes Rot	Lampenfehler	Unterbrechung oder Kurzschluss oder LED-Fehler
Schnelles rotes Blinken (0,25 Sek. an, 0,25 Sek. aus)	Fehler bei der Batteriekapazität	Haltbarkeitstest Batterie ausgefallen
Langsames rotes Blinken (1 Sek. an, 1 Sek. aus)	Batteriefehler	Falsche Batteriespannung oder Kurzschluss oder Unterbrechung
Grün und Rot aus	Batteriebetrieben	Notfallmodus: Netzwerk getrennt oder fehlendes Netzwerk

Indicateur LED État du système localement par un indicateur LED bicolor		
Indication LED	Statut	Description
Vert permanent	Veille, système OK	Mains operation, battery is charged
Clignotement rapide en vert (0,25 s allumé, 0,25 s éteint)	Function test underway	Function test underway
Clignotement lent vert (1 s allumé, 1 s éteint)	Duration test underway	Duration test underway
Rouge permanent	Lamp failure	Open Circuit or Short circuit or LED failure
Clignotement rapide en rouge (0,25 s allumé, 0,25 s éteint)	Battery capacity failure	Battery failed duration test
Rouge clignotant lentement (1 s allumé, 1 s éteint)	Battery fault	battery voltage or Short circuit or Open Circuit
Vert et rouge éteints	Battery Operation	Emergency mode: Mains disconnected or Mains failure

# LED EMERGENCY KIT **DALI 2** 1,8W - 90V - SA-SE

**AUTOTEST**

Inverter di emergenza LED a potenza costante - *Constant power LED inverter*



**NEW**



- Sistema LED autonomo per illuminazione di emergenza con interfaccia DALI e funzione di test automatico
- Per moduli LED con tensione continua 10-90Vdc
- Batteria al litio ferro fosfato plug-in incorporata
- 2 anni di garanzia elettronica
- 4 anni di garanzia sulla batteria
- Funzionamento SA/SE
- Alimentazione bus DALI integrata
- Spegnimento automatico dell'uscita se il carico del LED è fuori range
- Potenza costante, corrente di uscita autoregolante
- Sistema di carica elettronico
- Protezione batteria da scarica profonda
- Collegamento della batteria a prova di cortocircuito
- Protezione del carico scollegato o in corto circuito
- Protezione contro l'inversione di polarità della batteria
- REEC30L è SELV
- Self-contained emergency lighting LED driver with DALI interface and automatic test function
- For LED module with a forward voltage of 10-90Vdc
- Plug-in Lithium Iron Phosphate battery
- 4 years guarantee electronic
- 2 years guarantee battery
- Maintained/Non-maintained operation
- Integrated DALI bus power supply
- Automatic shutdown of output if LED load is out of range
- Constant power output, output current self-adjustable
- Electronic charge system
- Deep discharge protection
- Short-circuit-proof battery connection
- Open-circuit-proof / short-circuited
- Polarity reversal protection for battery
- REEC30L is SELV output voltage

Dimensioni (mm) - Dimensions (mm)

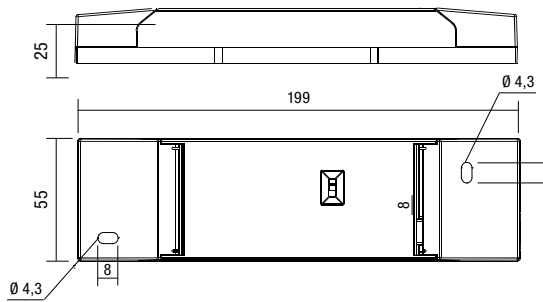

**Conforme alle seguenti Norme**  
**In Compliance with the following Standards**

EN61347-2-13	EN55015
EN61347-2-7	EN60598-2-22
EN61547	EN61000-3-2
EN62386	

Article	V Hz	Supply current mA max	I out mA max-min	V out min	V out max	W max	Autonomy (h)	Flux %	ta °C	PCS	Codice Code
LINEAR INVERLED DALI 1,8W - 90V - SA-SE	220-240V - 50/60Hz	25	120-20	15	90	1,8	3	●	0...55	6	REEC30L

● (1,8W : lamp power) x 100

- 1 - Tutte le specifiche sono tipiche per alimentazione 230 V CA, salvo diversa indicazione - All specifications are typical on the 230VAC unless otherwise stated
- 2 - Il test di funzionamento in emergenza deve essere eseguito quando una batteria è completamente carica per 16/24 ore  
The emergency function test must be performed when a battery is fully charged for 16/24 hours



# LED EMERGENCY KIT 1,8W - 90V - SA-SE

Inverter di emergenza LED a potenza costante - *Constant power LED inverter*

## Schema di collegamento - Wiring diagram

La massima tensione di uscita a vuoto è 90V  
The maximum no-load voltage of the drive is 90V

Linea non commutata

Un-switched line

Neutro - Neutral

DALI

DALI

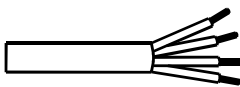

max.  $\varnothing$  = 6mm  
min.  $\varnothing$  = 3mm

Linea commutata

Switched line

SLin Neutro - Neutral

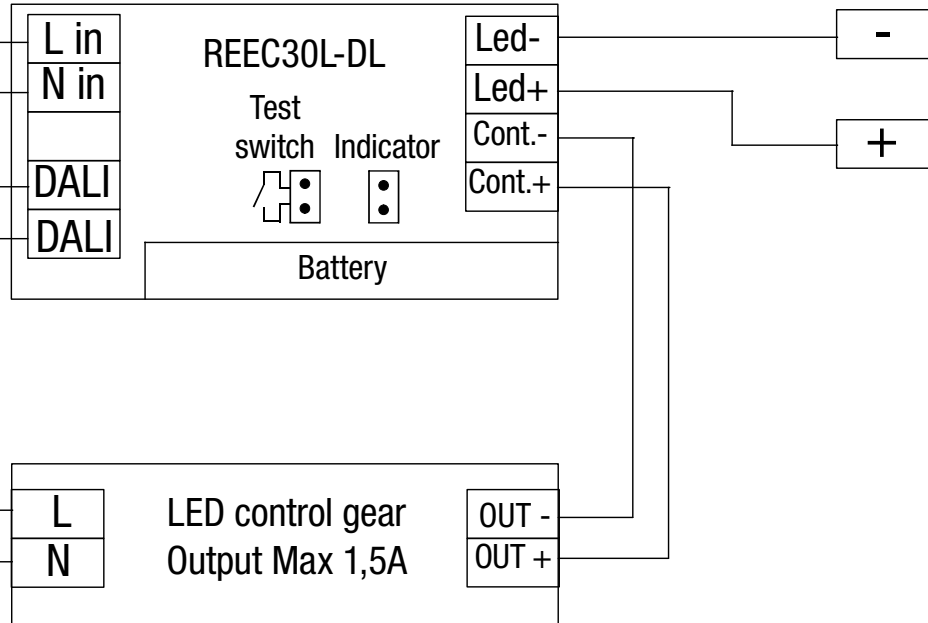

Nei seguenti casi, il LED di segnalazione sarà spento.

- 1 - Manca l'alimentazione di rete, la luce va in emergenza.
- 2 - La batteria è scollegata quando l'alimentazione è attiva.
- 3 - La batteria deve essere ricollegata dopo essere stata scollegata con rete presente (Attenzione: in tal caso scollegare la rete e ricollegarla)
- 4 - Il driver Led applicabile deve essere isolato da tensione di rete non può superare i 100 V, la corrente non può superare 1,5 A.
- 5 - Quando lo SLin è collegato, il modulo LED è acceso  
Quando SLin è disconnesso, il modulo LED è spento (SE).

With the following cases, the indicator will be off.

- 1 - Mains power off, the light goes into emergency mode.
- 2 - Battery is disconnect when mains power on.
- 3 - Battery be connected again after disconnected when mains power on (Attention: In that case, please re-set the AC mains power)
- 4 - The applicable Led driver should be isolated, and max. voltage can not over 100V, max. current can not over 1.5A.
- 5 - When the SLin is connected, the LED light is under maintained  
When SLin is disconnected, the LED lights is non maintained

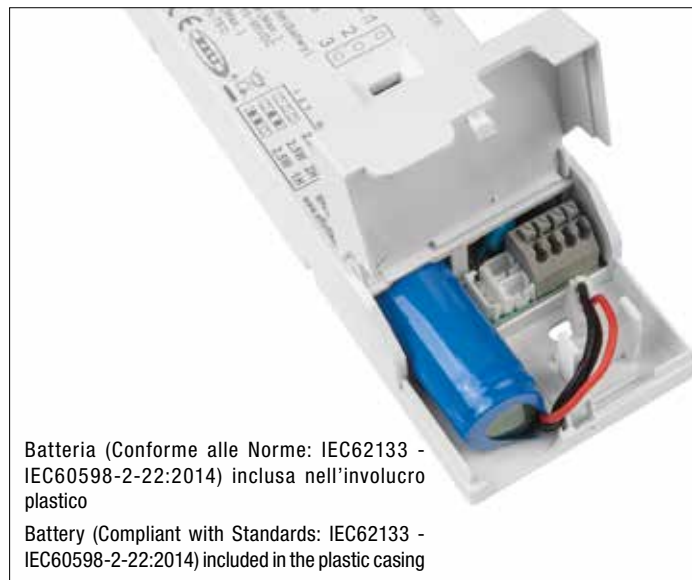

Batteria (Conforme alle Norme: IEC62133 - IEC60598-2-22:2014) inclusa nell'involucro plastico

Battery (Compliant with Standards: IEC62133 - IEC60598-2-22:2014) included in the plastic casing

**Avviso:** passaggi per la sostituzione della batteria

- 1 - Aprire prima il coperchio superiore
  - 2 - Togliere la batteria
  - 3 - Installare la batteria
  - 4 - Richiudere il coperchio
- La batteria deve essere sostituita quando non assicura l'autonomia richiesta.
  - La batteria è sostituibile.
  - L'isolamento è fornito lato modulo LED.
  - Se è necessario premere il filo della spia e il pulsante di test, è necessario piegare il filo sopra il filo di uscita.
  - Protezione incorporata nella batteria con connessione anti-inversione, cortocircuito, sovraccarico, scarica eccessiva e altre funzioni di protezione.

**Notice:** Battery replacement steps

- 1 - Open the top cover first
  - 2 - Take off the battery
  - 3 - Setup the battery
  - 4 - Close up the cover
- The battery should be changed when the battery be failed on charging's ability.
  - The battery is replaceable.
  - Building insulation is in the LED module slide.
  - If it is necessary to press the wire of the indicator light and the test button, it is necessary to fold the wire above the output wire.
  - Built-in protection plate of battery pack with anti-reverse connection, short circuit, overcharge, overdischarge and other protection function.

# LED EMERGENCY KIT 1,8W - 90V - SA-SE

**AUTOTEST**

**LED-Notwechselrichter mit konstanter Leistung - Inverter de secours LED à puissance constante**

## Batteria - Battery

- Celle della batteria ad alta temperatura - High temperature grade battery cells
- Batteria 6,4 LiFePO4 - 6,4 LiFePO4 battery
- Presa maschio/femmina per un collegamento semplice - Male/female socket for simple connection

## Batteria LiFePO4 - LiFePO4 battery

- Intervallo di temperatura della custodia per garantire 4 anni di durata del progetto: 0°..60°C  
Case temperature range to ensure 4 years design life: 0°..60°C
- Volt batteria - Battery voltage: 3,2V per cell
- Capacità 18650 - 1500mAh - Capacity: 18650 - 1500mAh

## Indicazione di stato LED verde Status indication Green LED

- Un LED verde indica che la corrente di carica scorre nella batteria  
A green LED indicates that charging current is flowing into the battery
- Collegamento a spina 1  
Plug connection 1



## Test switch

- Per il collegamento all'unità di illuminazione di emergenza  
For connection to the emergency lighting unit
- Per controllare il funzionamento del dispositivo  
For checking the device function
- Plug connection  
Collegamento a spina



## TESTING COMMISSION DALI

REEC30L-DL Serie DALI è conforme ai protocolli standard IEC62386-102 e IEC 62386-202(DT1). È perfettamente compatibile con il sistema di controllo DALI di Tridonic, Osram, Philips e altri famosi marchi internazionali.

- 1 - Con una varietà di funzioni della modalità di lavoro: modalità normale, modalità di emergenza, modalità di riposo, modalità inibizione e modalità di test della durata
- 2 - L'intervallo di tempo del test funzionale e l'intervallo di tempo del test di durata possono essere impostati e letti per personalizzare la funzione di test automatico.
- 3 - Registrazione e lettura automatica delle ore di lavoro e di emergenza della serie REEC30L-DL
- 4 - Varie letture dello stato normale e di emergenza

## Controllo DALI

- 1 - Un comando DALI da un'unità di controllo idonea può essere utilizzato per avviare test di funzionamento e autonomia in orari selezionati individualmente I flag di stato vengono impostati per la segnalazione e la registrazione dei dati dei risultati.
- 2 - Quando non è stato collegato un bus DALI o quando è collegato un bus DALI ma i tempi di DELAY e INTERVAL non sono stati quindi reimpostati inviando opportuni comandi DALI il REEC30L-DL eseguirà i test in conformità con i tempi predefiniti impostati all'interno del REEC30L-DL.
- 3 - Questi tempi predefiniti sono preimpostati in fabbrica, in conformità con lo standard DALI EN 62386-202, per eseguire un test di funzionamento automatico ogni 7 giorni e un test di autonomia ogni 180 giorni. Poiché il tempo di RITARDO è preimpostato in fabbrica su Zero, tutte le unità vengono testate contemporaneamente. I tempi di prova possono essere modificato con un comando sul bus DALI.

## TESTING COMMISSION (DALI)

REEC30L-DL DALI series comfort IEC62386-102 and IEC 62386-202(DT1) standard protocol. It is perfectly compatible with DALI control system of Tridonic, Osram, Philips and other famous international brands.

- 1 - With a variety of working mode switching functions, normal mode, emergency mode, rest mode, inhibit mode function test mode and duration test mode
- 2 - Functional test time interval and duration test time interval can be set and read to achieve automatic test function
- 3 - Automatic recording and reading of REEC30L-DL series working time and emergency time
- 4 - Various normal and emergency status reads

## DALI CONTROL

- 1 - A DALI command from a suitable control unit can be used to initiate function and duration tests at individually selected times Status flags are set for report back and data logging of results.
- 2 - When a DALI bus has not been connected or when a DALI bus is connected but the DALI default DELAY and INTERVAL times have not been re-set by sending appropriate DALI commands, then the REEC30L-DL will conduct self-tests in accordance with the default times set within the REEC30L-DL.
- 3 - These default times are factory pre-set, in accordance with the DALI standard EN 62386-202, to conduct an automatic function test every 7 days and a duration test every 180 days. Since the DELAY time is factory pre-set to Zero, all units are tested at the same time. Test times can be changed with a command over the DALI bus.

Indicatore LED Stato del sistema in locale da un indicatore LED bicolore		
Indicazione LED	Stato	Descrizione
Verde permanente	Standby, sistema OK	Funzionamento a rete presente e/o batteria in carica
Verde lampeggiante veloce (0,25s acceso 0,25 s spento)	Test funzionale in corso	Test funzionale in corso
Verde lampeggiante lento (1s acceso 1s spento)	Test di durata in corso	Test di durata in corso
Rosso permanente	Guasto della lampada	Circuito aperto o cortocircuito o guasto del LED
Rosso lampeggiante veloce (0,25 s acceso 0,25 s spento)	Errore di capacità della batteria	Test di durata della batteria fallito
Rosso lampeggiante lento (1s acceso 1s spento)	Guasto batteria	Tensione della batteria errata o cortocircuito o circuito aperto
Verde e Rosso spenti	Funzionamento a batteria	Modalità di emergenza: rete disconnessa o mancanza di rete

Indicator LED System status in locally by a bi-color indicator LED		
LED indication	Status	Description
Permanent Green	Standby, system OK	Mains operation, battery is charged
Fast flashing Green (0.25s on 0.25s off)	Function test underway	Function test underway
Slow flashing Green (1s on 1s off)	Duration test underway	Duration test underway
Permanent Red	Lamp failure	Open Circuit or Short circuit or LED failure
Fast flashing Red (0.25s on 0.25s off)	Battery capacity failure	Battery failed duration test
Slow flashing Red (1s on 1s off)	Battery fault	battery voltage or Short circuit or Open Circuit
Green and Red off	Battery Operation	Emergency mode: Mains disconnected or Mains failure

DALI 2

LED Safety Lighting



# LED EMERGENCY KIT 3/6W - 80V - SA-SE

Kit di emergenza LED a **potenza costante** - **Constant power LED emergency Kit**



Batteria e copri morsetti inclusi  
Included battery and terminal cover



Sistema di emergenza che permette il funzionamento di apparecchi di illuminazione con led di potenza o faretto LED anche quando viene a mancare l'energia elettrica. Il sistema si compone di un inverter elettronico con uscita a potenza costante e da una batteria integrata del tipo LiFePO4.

Sono possibili 2 modalità di funzionamento:

- **SA:** funzionamento permanente, vedi fig. 2 (in caso di assenza di energia elettrica, l'apparecchio di illuminazione rimane acceso seppur con luminosità ridotta);
- **SE:** funzionamento non permanente, vedi fig. 3 (in caso di assenza di energia elettrica, l'apparecchio di illuminazione a cui è collegato, si accende).

Per il funzionamento in modalità permanente l'apparecchio di illuminazione deve essere dotato del suo driver.

**Principali caratteristiche tecniche:**

- Flusso luminoso costante in caso di emergenza
- Non necessita di selezione della tensione di uscita
- Fornisce sempre una potenza costante, qualunque sia il carico collegato, nel range di tensione di uscita 9-80V
- SELV (Bassa tensione di sicurezza)
- Circuito di protezione della batteria contro la scarica prolungata
- LED verde indicante il collegamento alla rete di alimentazione (lunghezza standard del cavo, 600mm)
- Disaccoppiamento in uscita tramite relè
- Morsetti di collegamento alla linea permanente e di inibizione a cablaggio automatico
- Inibizione tramite interruttore
- Sezione cavi di ingresso da 0,75 a 1,5 mm<sup>2</sup>
- Sezione cavi di uscita da 0,75 a 1,5 mm<sup>2</sup>
- Tempo di intervento <= 800msec
- Tempo di ricarica: 12h (65151LED80CP1) - 24h (65151LED80CP2 - 65151LED80CP3)
- Foro di fissaggio del LED: Ø 9mm
- Distanza massima dal driver: 2m

**Emergency system that ensures the operation of lighting appliances with power LEDs even in the event of power cuts. The system consists of an electronic inverter with a constant power output and a built-in LifePO4 battery**

**There are 2 possible operating modes:**

- **SA:** permanent, see fig. 2 (in the event of a power cut, the lighting appliance remains on even though with reduced brightness);
- **SE:** non-permanent, see fig. 3 (in the event of a power cut, the lighting appliance to which it is connected turns on).

For operation in permanent mode, the lighting appliance must be equipped with its driver.

**Main technical features:**

- Constant luminous flux in the event of an emergency
- No need to set the maximum output voltage
- The output power is always 3, independent from the connected load in the range 9-80V of the output voltage
- SELV (Safety extra low voltage)
- Battery protection circuit against prolonged discharging
- Green LED indicating connection to the power supply (standard cable length, 600mm)
- Terminals for connection to the permanent line and automatic wiring inhibition
- Inhibition control through a switch
- Input cable cross-section from 0.75 to 1.5 mm<sup>2</sup>
- Output cable cross-section from 0.75 to 1.5 mm<sup>2</sup>
- Intervention time <= 800msec
- Charging time: 12h (65151LED80CP1) - 24h (65151LED80CP2 - 65151LED80CP3)
- LED fixing hole: Ø 9mm
- Maximum distance from the driver: 2m

Conforme alle seguenti Norme  
In Compliance with the following Standards

EN61347-2-13	EN55015
EN61347-2-7	EN60598-2-22
EN61547	EN61000-3-2

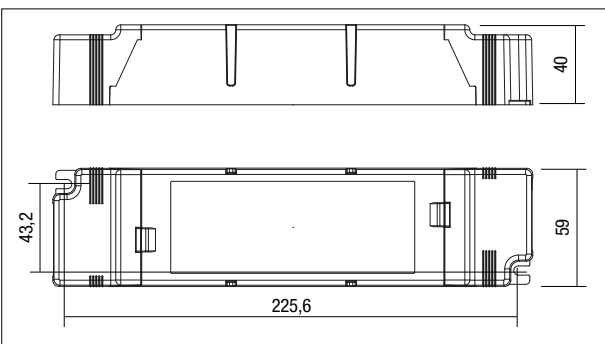

Article	V Hz	Supply current mA	I out mA	V out min	V out max	W max *	Autonomy (h)	Flux %	ta °C	LPH	Code	PCS	CCM cm <sup>2</sup>
LED EMERGENCY KIT 3W SA-SE 1h	220-230V 50/60Hz	16	37,5-333	9V	80V	3	1	●	0...40	240x59x40	65151LED80CP1	1	670,82
LED EMERGENCY KIT 3W SA-SE 3h	220-230V 50/60Hz	25	37,5-333	9V	80V	3	3	●	0...40	240x59x40	65151LED80CP3	1	670,82
LED EMERGENCY KIT 6W SA-SE 2h	220-230V 50/60Hz	25	72-640	9V	80V	5,8	2	●	0...40	240x59x40	65152LED80CP2	1	670,82

● (\* Wmax/ Wlamp) x100

# LED EMERGENCY KIT 3/6W - 80V - SA-SE

Kit di emergenza LED a **potenza costante** - *Constant power LED emergency Kit*

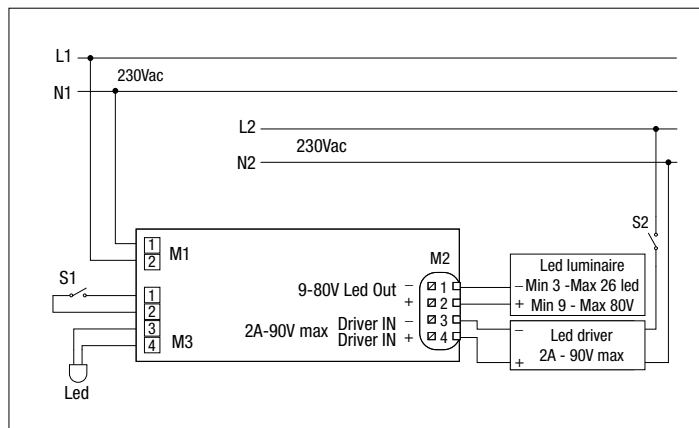

**Fig. 1**  
Schema di collegamento SA (Sempre Accesa)  
Wiring diagram SA (Always on)

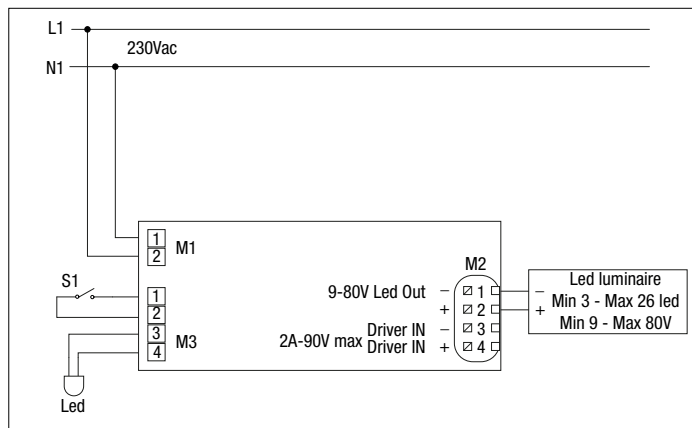

**Fig. 2**  
Schema di collegamento SE (Solo Emergenza)  
Wiring diagram SE (Only Emergency)

## Esempio applicativo - Application example

**SE**

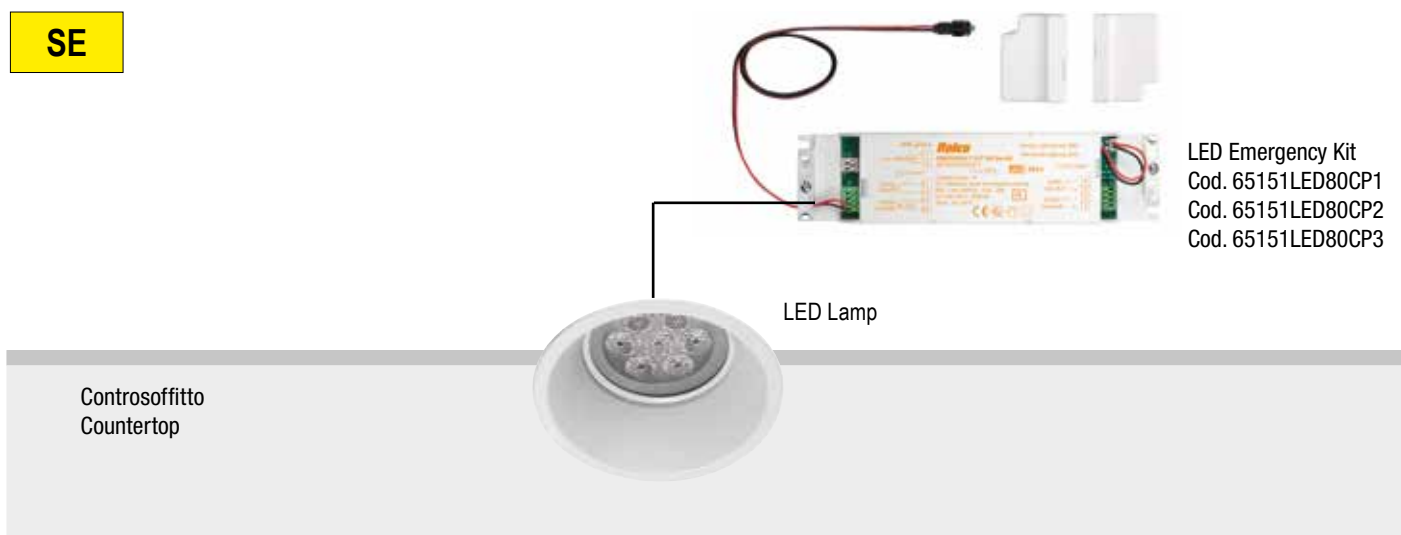

**SA**

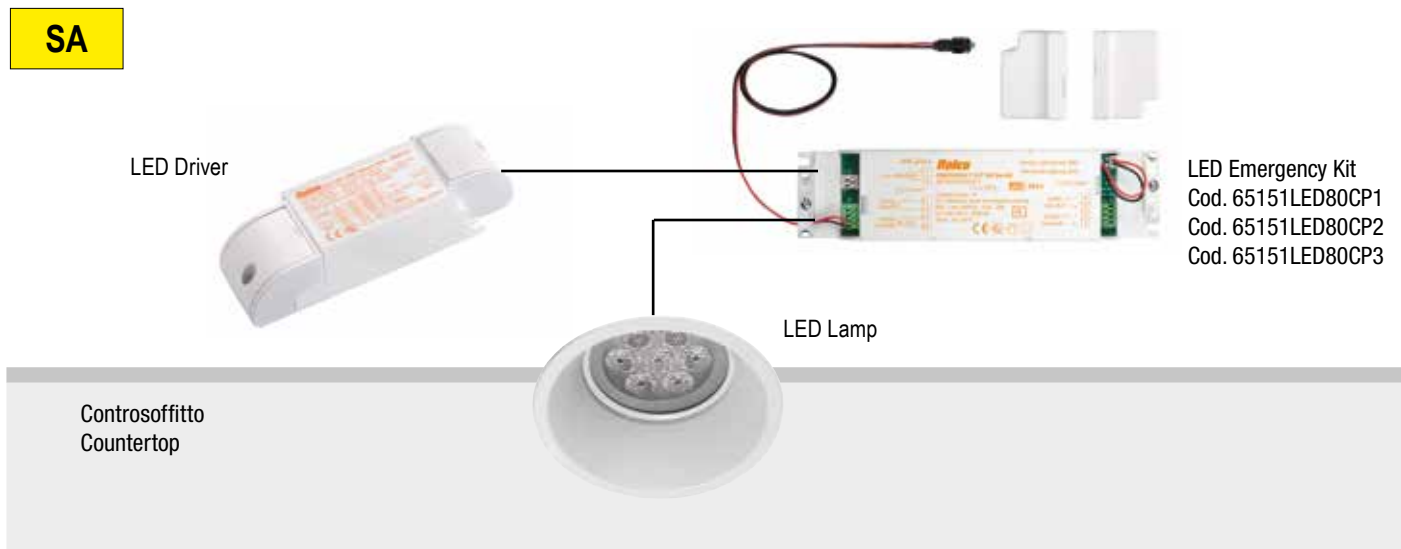

# LED EMERGENCY KIT 3,5W - 52V - SA-SE

**AUTOTEST**

Kit di emergenza LED a **potenza costante** - **Constant power LED emergency Kit**



Batteria (Conforme alle Norme: IEC62133 - IEC60598-2-22:2014) e copri morsetto incluso  
Included battery (standard: IEC62133 - IEC60598-2-22:2014) and terminal cover

**NEW**



**Sistema di emergenza per uso indipendente per faretto LED a potenza costante con batteria LiFePO4 inclusa**

**Sono possibili due modalità di funzionamento:**

**SA:** Funzionamento permanente. Il faretto LED in questa configurazione funzionerà normalmente con comando ON/OFF dedicato e in caso di blackout entrerà in modalità emergenza (Fig. 3).

**SE:** Funzionamento non permanente. Il faretto LED sarà sempre spento e si accenderà solo in caso di blackout (Fig. 4).

Per il funzionamento in modalità SA, il Kit RP0714CP3, dovrà anche essere collegato ad un driver LED. Il driver non è incluso.

**Principali caratteristiche tecniche:**

- Autotest conforme alla IEC 62034 (stato della batteria, test di funzionamento, test durata batteria)
- Rest mode
- Protezione al sovraccarico
- Flusso costante in emergenza
- Non necessita di selezione della tensione di uscita
- Fornisce sempre una potenza costante di 3,5W qualunque sia la tensione del carico, nel range di tensione di uscita 15-52V.
- Circuito di protezione della batteria contro la scarica prolungata.
- LED Rosso/Verde indicante lo stato dell'Inverter (vedi tabella). Lunghezza standard del cavo 600mm
- Disaccoppiamento del carico tramite relè
- Relè di ingresso (linea di alimentazione del driver)
- Morsetti ad innesto rapido su linea driver, uscita e di inibizione
- Inibizione tramite controllore opzionale (Cod. DALI-PS-DIN)
- Pulsante di test opzionale (Cod. 24500700)
- Sezione cavi di ingresso da 0,75 a 1,5 mm<sup>2</sup>
- Sezione cavi di uscita da 0,75 a 1 mm<sup>2</sup>
- Tempo di intervento <= 800msec
- Foro di fissaggio del LED: Ø 9mm
- Batteria (Conforme alle Norme: IEC62133 - IEC60598-2-22:2014) inclusa nell'involucro plastico

**Independent emergency Kit for constant power LED Spotlight with LiFePO4 battery included**  
**There are 2 possible operating modes:**

**SA:** Permanent operation. The LED spotlight in this configuration will normally work with a dedicated ON / OFF command and in the event of a blackout it will go into emergency mode (Fig. 3).

**SE:** Non-permanent operation. The LED spotlight will always be off and will turn on only in the event of a blackout (Fig. 4).

For permanent operation, the Kit RP0714CP3 must be connected to a LED driver. The LED driver is not included.

**Technical characteristics**

- Self-test according to IEC 62034 (battery status, function test, battery life test)
- Rest mode
- Overload protection
- Constant flow in an emergency
- Does not need to select the output voltage
- Always supplies a constant power 3,5W whatever the load voltage, in the 15-52V output voltage range
- Battery protection circuit against prolonged discharge.
- Red / Green LED indicating the inverter status (see table). Standard cable length 600mm
- Decoupling via relay
- Input Relay (Driver Power Line)
- Inhibition via optional controller (Cod. DALI-PS-DIN)
- Optional test button (Cod. 24500700)
- Cables from 0,75 to 1,5mm<sup>2</sup> (input side)
- Cable from 0,75 to 1mm<sup>2</sup> (output side)
- Intervention time <= 800msec
- LED fixing hole: Ø 9mm

**Battery (Compliant with Standards: IEC62133 - IEC60598-2-22:2014) included in the plastic casing**

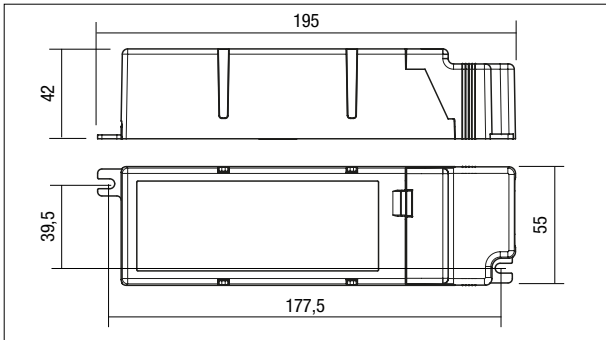

Conforme alle seguenti Norme  
In Compliance with the following Standards

EN61347-2-13	EN55015
EN61347-2-7	EN60598-2-22
EN61547	EN61000-3-2

Article	V Hz	Supply current mA	I out mA	V out min	V out max	W max	Autonomy (h)	Flux %	ta °C	Codice Code
LED EMERGENCY KIT 3,5W - 52V - SA-SE	220-240V - 50/60Hz	50	230-67	15	52	3,5	3	●	5...40	RP0714CP3

● 3,5W / lamp power x100









È possibile inserire più COB in serie purchè la tensione complessiva sia inferiore o uguale a 52V

It is possible to insert several COB LEDs in series, making sure that the overall voltage is less or equal 52V

# LED EMERGENCY KIT 3,5W - 52V - SA-SE

**AUTOTEST**

Kit di emergenza LED a **potenza costante** - *Constant power LED emergency Kit*

Colore LED - LED indication		Stato - Status
	Verde fisso - Permanent Green	Batteria carica o in carica - Battery charge or charging
	Verde lampeggiante - Flashing Green	Funzione TEST avviata - TEST in progress
	Verde lampeggiante lento (1s ON - 1s OFF) Slow flashing green (1s ON - 1s OFF)	TEST di autonomia avviato Autonomy TEST in progress
	Rosso fisso - Permanent Red	Lampada guasta - Lamp failure
	Rosso lampeggio veloce (0,1s ON - 0,1s OFF) Fast flashing Red (0,1s ON - 0,1s OFF)	Guasto circuito di ricarica - Charging failure
	Lampeggio Rosso lento (1s ON - 1s OFF) Slow flashing Red (1s ON - 1s OFF)	Batteria guasta - Battery failure
	Verde e Rosso OFF - Green and Red OFF	Emergenza ON - Emergency ON

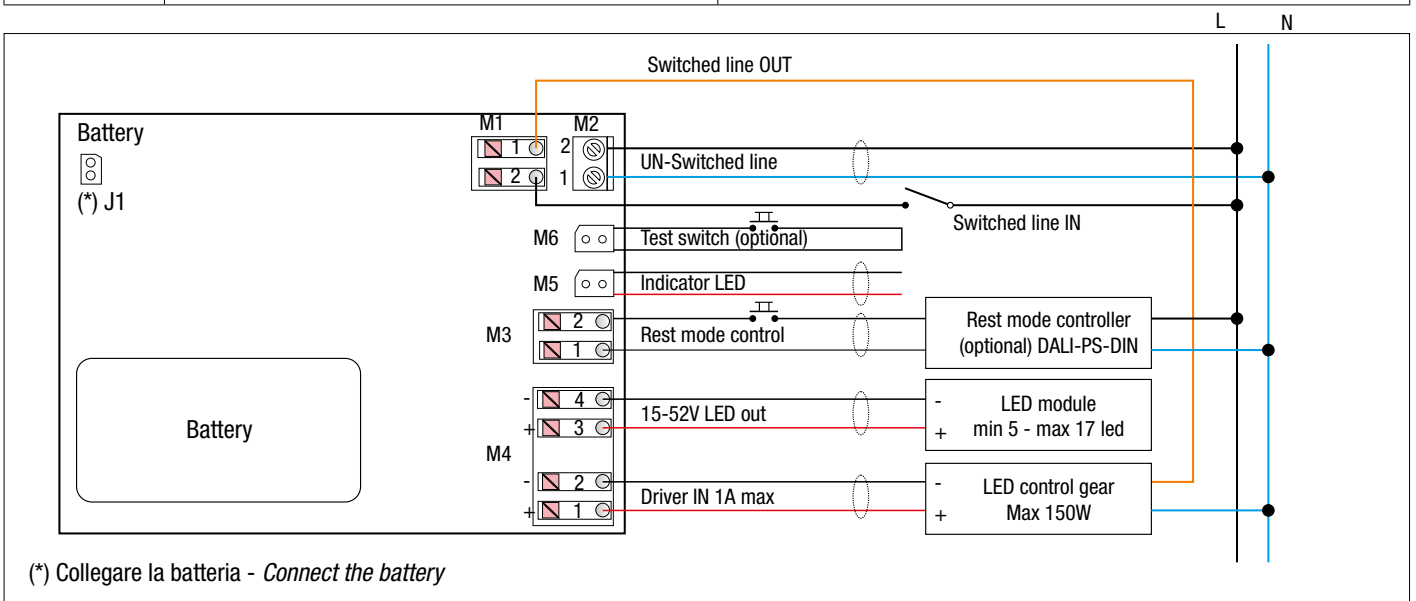

**Fig. 3**  
Schema di collegamento SA (Sempre Accesa)  
Wiring diagram SA (Always on)

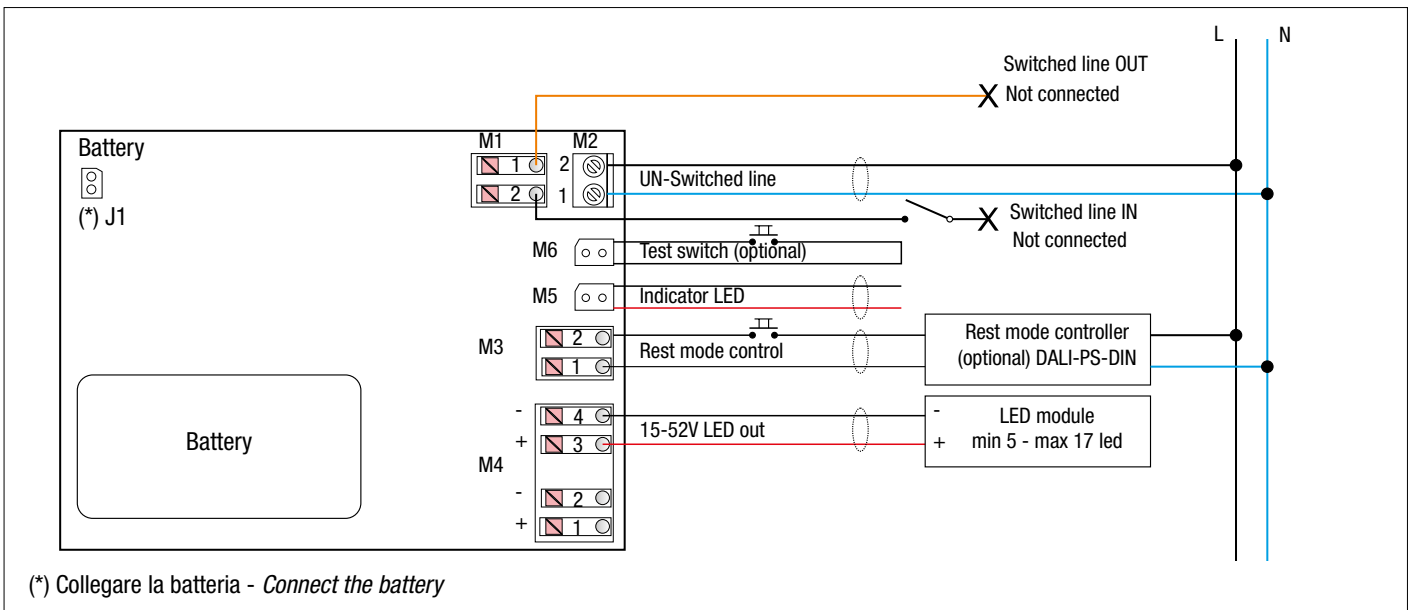

**Fig. 4**  
Schema di collegamento SE (Solo Emergenza)  
Wiring diagram SE (Only Emergency)

# LED EMERGENCY KIT IP67

Kit di emergenza LED a **potenza costante** - **Constant power LED emergency Kit**



SELV



IP67

Batteria inclusa  
Included battery



Dimensioni (mm) - Dimensions (mm)

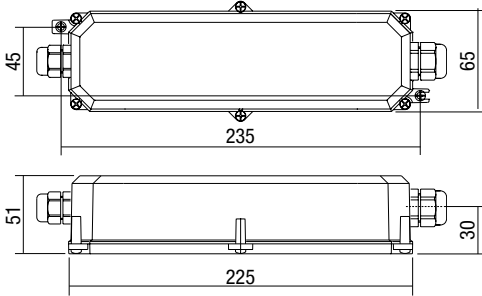

Esempio applicativo - Application example



**Sistema di emergenza che permette il funzionamento di apparecchi di illuminazione con led di potenza o faretti LED anche quando viene a mancare l'energia elettrica. Il sistema si compone di un inverter elettronico con uscita a potenza costante e da una batteria integrata del tipo LiFePO4.**

**Sono possibili 2 modalità di funzionamento:**

- **SA:** funzionamento permanente, vedi fig. 2 (in caso di assenza di energia elettrica, l'apparecchio di illuminazione rimane acceso seppur con luminosità ridotta);
- **SE:** funzionamento non permanente, vedi fig. 3 (in caso di assenza di energia elettrica, l'apparecchio di illuminazione a cui è collegato, si accende).

Per il funzionamento in modalità permanente l'apparecchio di illuminazione deve essere dotato del suo driver.

**Principali caratteristiche tecniche:**

- Flusso luminoso costante in caso di emergenza
- Non necessita di selezione della tensione di uscita
- Fornisce sempre una potenza costante, qualunque sia il carico collegato, nel range di tensione di uscita 9-80V
- SELV (Bassa tensione di sicurezza)
- Circuito di protezione della batteria contro la scarica prolungata
- LED verde indicante il collegamento alla rete di alimentazione (lunghezza standard del cavo, 600mm)
- Disaccoppiamento in uscita tramite relè
- Morsetti di collegamento alla linea permanente e di inibizione a cablaggio automatico
- Inibizione tramite interruttore
- Sezione cavi di ingresso da 0,75 a 1,5 mm<sup>2</sup>
- Sezione cavi di uscita da 0,75 a 1,5 mm<sup>2</sup>
- Tempo di intervento <= 800msec
- Tempo di ricarica: 24h
- Foro di fissaggio del LED: Ø 9mm
- Distanza massima dal driver: 2m

**Emergency system that ensures the operation of lighting appliances with power LEDs even in the event of power cuts. The system consists of an electronic inverter with a constant power output and a built-in LifePO4 battery**

**There are 2 possible operating modes:**

- **SA:** permanent, see fig. 2 (in the event of a power cut, the lighting appliance remains on even though with reduced brightness);
- **SE:** non-permanent, see fig. 3 (in the event of a power cut, the lighting appliance to which it is connected turns on).

For operation in permanent mode, the lighting appliance must be equipped with its driver.

**Main technical features:**

- Constant luminous flux in the event of an emergency
- No need to set the maximum output voltage
- The output power is always 3, independent from the connected load in the range 9-80V of the output voltage
- SELV (Safety extra low voltage)
- Battery protection circuit against prolonged discharging
- Green LED indicating connection to the power supply (standard cable length, 600mm)
- Terminals for connection to the permanent line and automatic wiring inhibition
- Inhibition control through a switch
- Input cable cross-section from 0.75 to 1.5 mm<sup>2</sup>
- Output cable cross-section from 0.75 to 1,5 mm<sup>2</sup>
- Intervention time <= 800msec
- Charging time: 24h
- LED fixing hole: Ø 9mm
- Maximum distance from the driver: 2m

IP67

Il grado IP67 garantisce la protezione totale alla penetrazione di corpi solidi e polveri, la protezione contro l'immersione in acqua momentanea per 30 minuti a 1 metro di profondità.

The IP67 rating ensures complete protection from penetrating solid bodies and dust ingress, and from temporary immersion in water for 30 minutes at a depth of 1 metre

Article	V Hz	Supply current mA	I out mA	V out min	V out max	W max	Autonomy (h)	Flux %	ta °C	LPH	Code	PCS	CCM cm <sup>3</sup>
LED EMERGENCY KIT 6W SA-SE 2h - IP67	220-230V 50/60Hz	25	72-640	9V	80V	5,8	2	●	0..40	240x59x40	65152IP67CP2	1	670,82
LED EMERGENCY KIT 3W SA-SE 3h - IP67	220-230V 50/60Hz	25	37,5-333	9V	80V	3	3	●	0..40	240x59x40	65152IP67CP3	1	670,82

# LED EMERGENCY KIT IP67

Kit di emergenza LED a **potenza costante** - **Constant power LED emergency Kit**

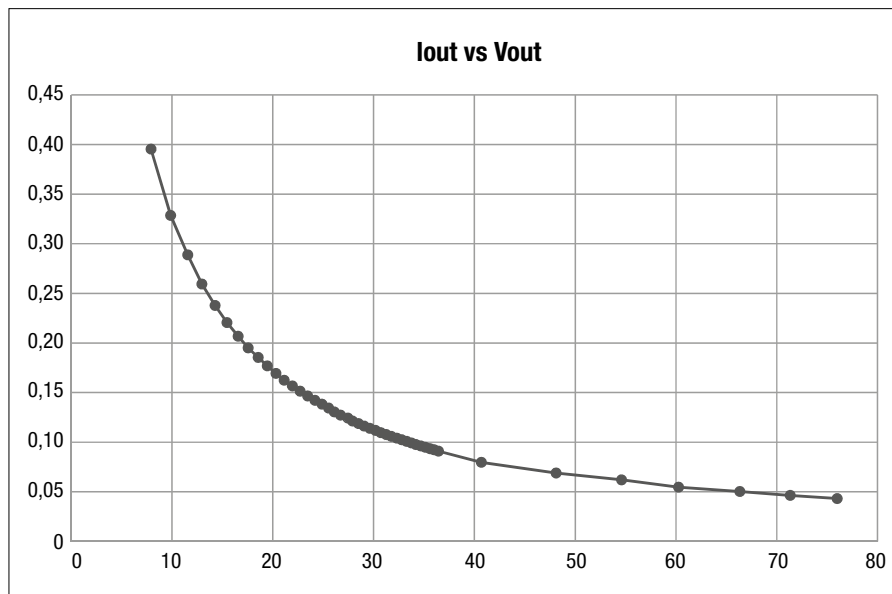

Fig. 1

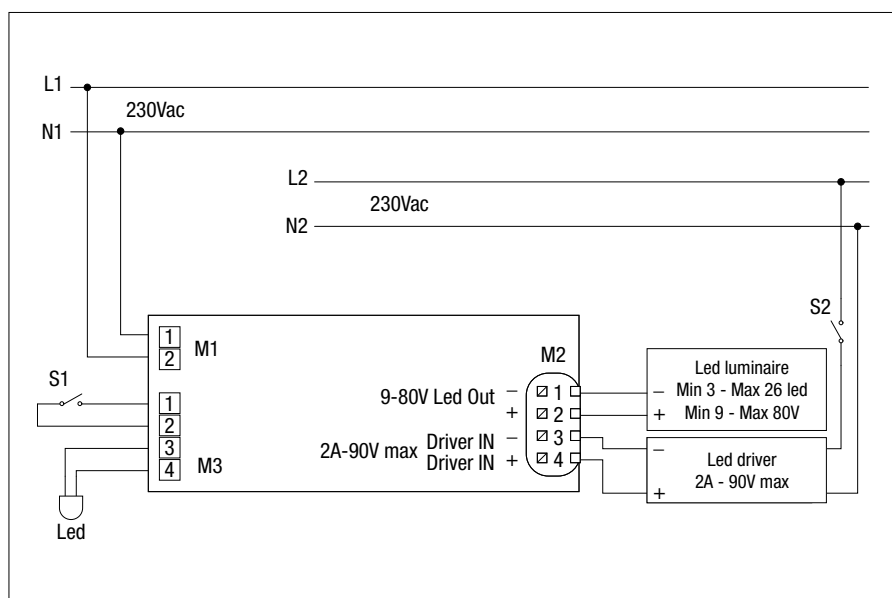

Fig. 2

Cod: 65151IP67CP1

Cod: 65151IP67CP3

Schema di collegamento SA (Sempre Accesa)

Wiring diagram SA (Always on)

Schéma de branchement SA (Toujours allumée)

Anschlussplan SA (Immer An)

Esquema de conexiòn SA (Siempre Activa)

Ledningsdiagram SA (Alltid Tændt)

Esquema de ligação SA (Sempre ligado)

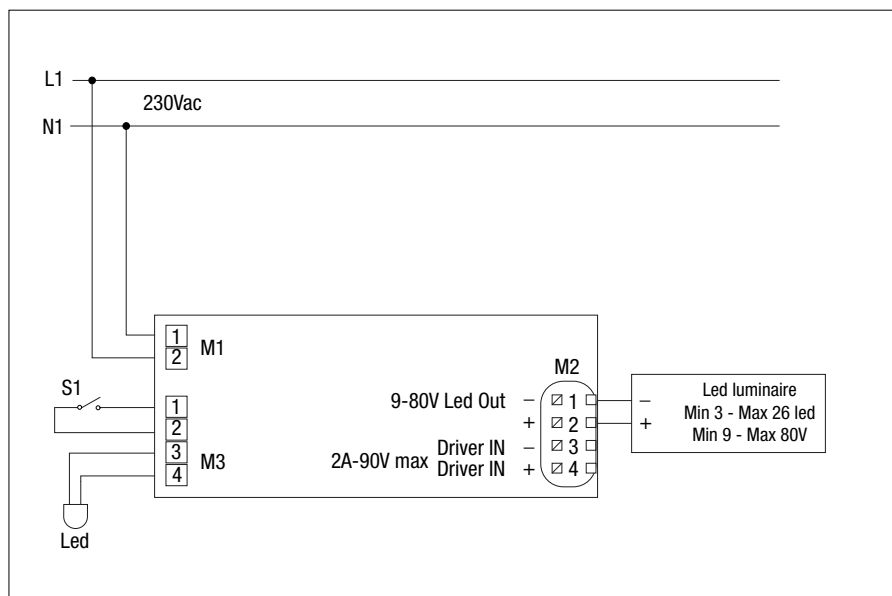

Fig. 3

Cod: 65151IP67CP1

Cod: 65151IP67CP3

Schema di collegamento SE (Solo Emergenza)

Wiring diagram SE (Only Emergency)

Schéma de branchement SE (Seulement urgence)

Anschlussplan SE (Nur Notleuchte)

Esquema de conexiòn SE (Solo Emergencia)

Ledningsdiagram SE (Kun Nødstilfælde)

Esquema de ligação SE (Apenas Emergência)

# LED Driver a SPINA - PLUG LED Driver



## SPINA JOLLY LED DIM

Spina LED multipower dimmerabile a PULSANTE passante su filo per moduli LED  
 Multipower dimmable led with PUSH BUTTON for LED moduls

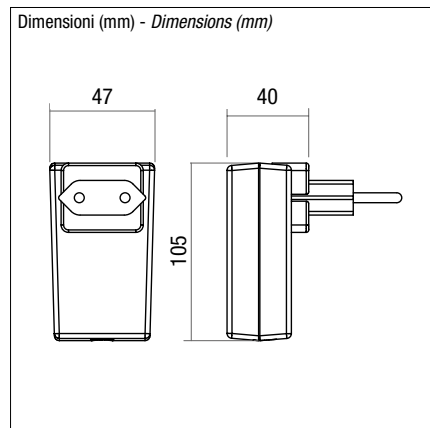

Codice Code	Colore Color	LPH ↓ mm	Vdc IN	Vac IN	DIM	Hz	REGAL?	iC	ta °C	tc °C	PFC	PCS	CCM cm <sup>3</sup>
RN1515SILENCE	N	106x49x40	176-264	110-240	Pulsante - Push	50/60	30	10A 40µS	35	75	OK	10	6.800
RN1515AU	N	106x49x40	176-264	220-240	Pulsante - Push	50/60	30	10A 40µS	35	75	OK	10	6.800

RN1515SILENCE RN1515AU		CDT															
I <sub>out</sub>	mA	200	250	300	350	400	450	500	550	600	650	700	750	800	850	900	950
V <sub>out</sub>	Vdc	42	42	42	42	42	42	42	42	42	42	42	42	42	42	42	42
Power	W	8	10	12	15	15	15	15	15	15	15	15	15	15	15	15	15
N° LED typical VF 3,2V	min-max	1÷12	1÷12	1÷12	1÷12	1÷11	1÷8	1÷8	1÷8	1÷7	1÷7	1÷6	1÷6	1÷5	1÷5	1÷4	1÷4

COB - Typical VF 37V

RN1515SILENCE RN1515AU		VDT	
V <sub>out</sub>	Vdc	12	24
Power	W	10	15

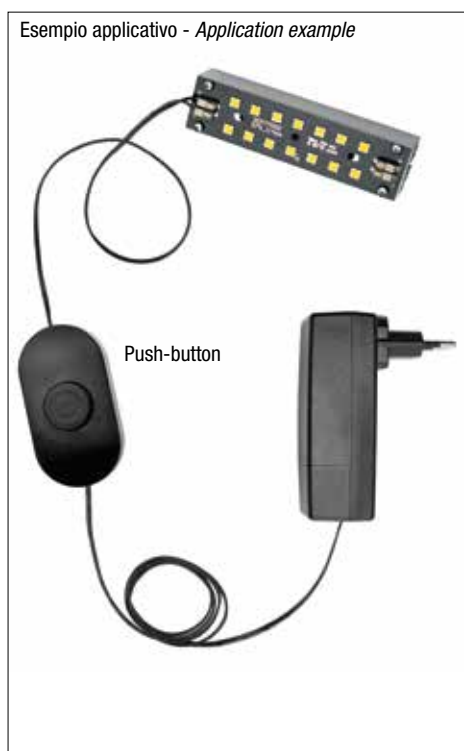

# LED Driver a SPINA - PLUG LED Driver



## Caratteristiche Tecniche:

Alimentatore elettronico dimmerabile per LED, con prese a spina intercambiabili per uso indipendente sia a tensione costante VDT 12-24V che a corrente costante CDT (vedi tabella). Completo di adattatori per EU e USA, accessori a richiesta: UK, CHINA, AUSTRALIA.

Regolazione a pulsante passante sul filo, tecnologia di regolazione (AM), per evitare problemi di rumore e sfarfallio ottico causati dalla tecnologia di regolazione PWM, risulta quindi assente anche il classico ronzio generato normalmente dai driver led, grazie all'uso di componenti che non generano rumore con frequenza PWM.

## Technical features:

Dimmable electronic driver for LEDs, with interchangeable plug sockets for independent use both with constant voltage VDT 12-24V and constant current CDT (see table). Complete with adapters for EU and USA, accessories on request: UK, CHINA, AUSTRALIA. Adjustment with push-button switch on the wire, regulation technology (AM), to avoid problems of noise and optical flickering caused by PWM control technology, it is therefore also absent the classic buzzing generated normally by LED drivers, thanks to the use of components that do not generate noise with PWM frequency.

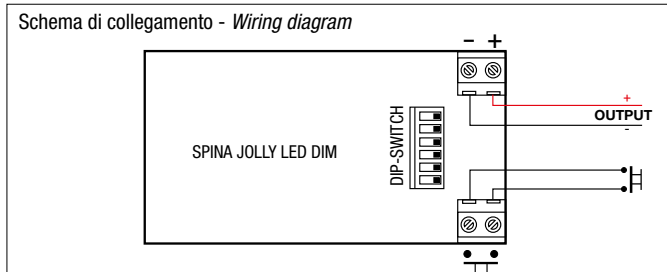

## Accessori per la regolazione non inclusi - Regulation accessories not included

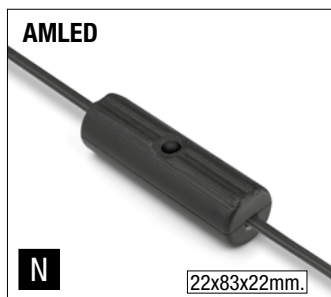

### AMPUSH - 450PUSH - D/661/N/LED

Pulsanti che devono essere abbinati solo all'articolo Spina Jolly LED DIM.

Aprire la parte superiore dell'involucro e cablare come da schema.

Il funzionamento avviene premendo direttamente sul pulsante posto sulla parte superiore dell'involucro.

Una breve pressione accende e spegne il carico, tenendo premuto si ottiene la regolazione del carico.

Al raggiungimento del livello di luminosità desiderato, interrompere la pressione.

*Push are two buttons that must be combined only with the item Spina Jolly LED DIM.*

*Tighten the clamps well and put the electronic circuit into the upper part of the casing.*

*Functioning takes place by directly pushing the button located at the top of the casing.*

*Press briefly to switch on and off the load. Hold pressed to regulate the load.*

*When the luminosity level has been reached, release the push button.*

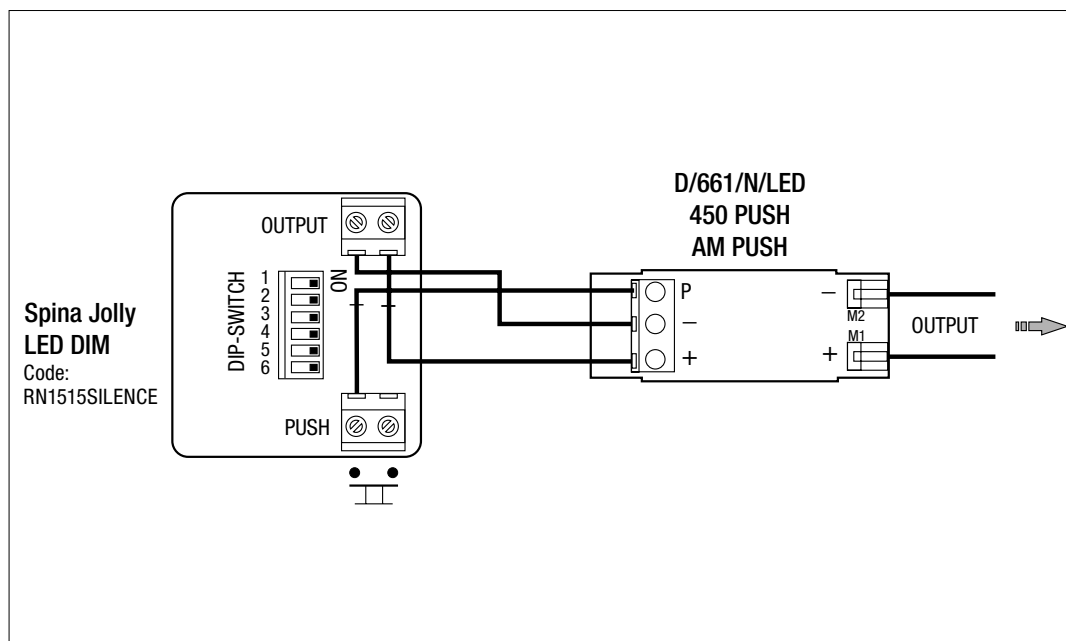

## Accessori spina non inclusi - Plug accessories not included



# LED Driver a SPINA - PLUG LED Driver



Spina LED passante su filo 24W o 60W - 24/48Vdc - LED Plug 24W or 60W - 24/48Vdc

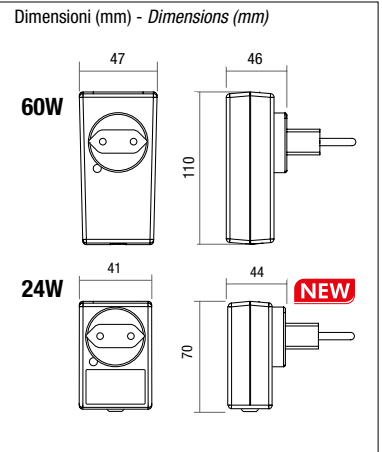

Codice Code	LPH mm	Vac IN	W	Vout Vdc	Iout mA	Hz	TOTAL	iC	ta °C	PFC	PCS	CCM cm <sup>3</sup>
BSG-2401000	44x44x73	100-240	24	24	1000	50/60	30	10A 40µS	35	0.9	10	6.800
BX-4801000	44x44x73	100-240	24	48	500	50/60	30	10A 40µS	35	0.9	10	6.800
BX-2402500	44x45x110	100-240	60	24	2500	50/60	30	10A 40µS	35	NO	10	6.800
ICPS5-480-1250	44x45x110	100-240	60	48	1250	50/60	30	10A 40µS	35	NO	10	6.800

**Caratteristiche tecniche:** alimentatore elettronico con presa intercambiabile per uso indipendente a tensione costante VDT 24-48V. Completo di adattatore per "EU" e "USA". Accessorio a richiesta "UK", Cina e Australia. Dimmerabile sul cavo con Dimmer **VDI** o **CDI**.  
**Cavo:** lunghezza 2,5m, tipo 2x0,75mm<sup>2</sup>

**Technical features:** electronic interchangeable plug led driver. Constant voltage VDT 24-48V. Provided with adapters to "EU" and "USA", accessories on request UK China and Australia. Dimmable on cable with **VDI** or **CDI** Dimmers.  
**Cable:** length 2.5m, type 2x0.75mm<sup>2</sup>.

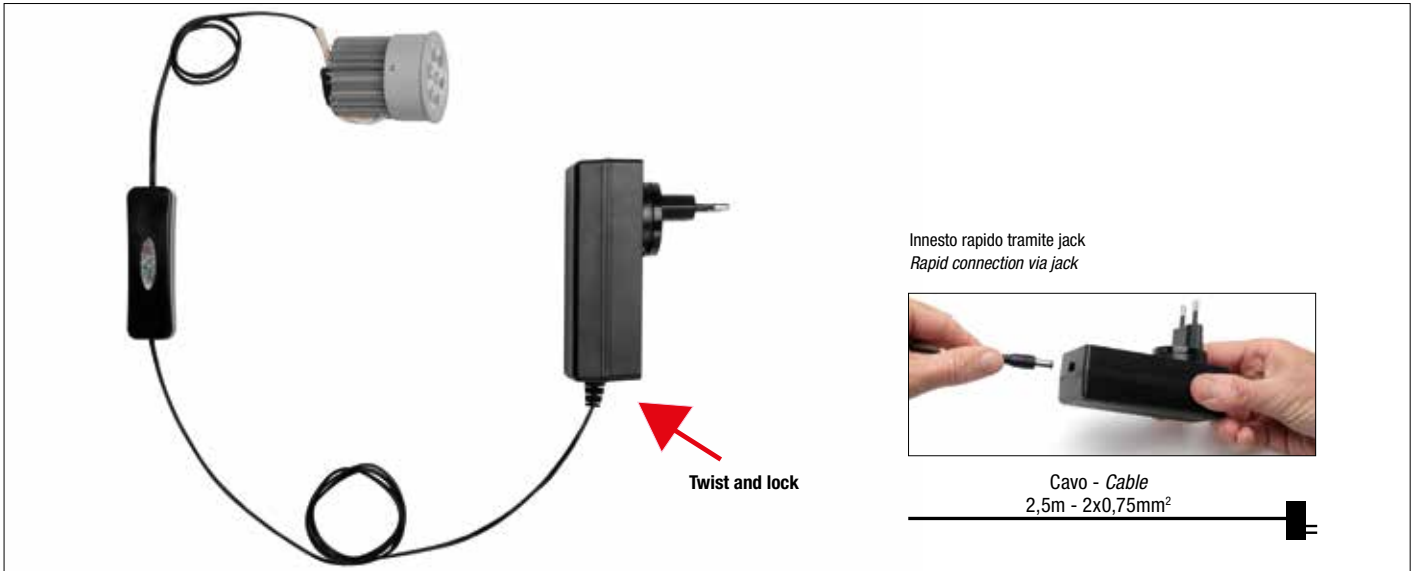

**Accessori spina non inclusi - Plug accessories not included**



Special projects

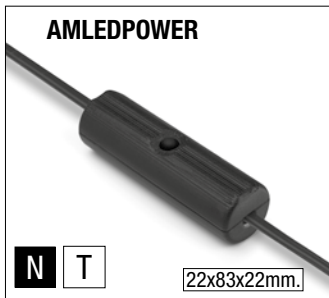

Codice Code	Colore Color	mA	ta °C	tc °C	in	out	PCS
RN1374/FILTRO	T	350 500 700	35	65	0,75	0,75	20
RN1374/FILTROB	N						
AMPOWER T	T						
450POWER N	N						

Dimmer per moduli LED. La selezione della corrente avviene tramite **jumper interno** (Fig. 1), con potenza da minimo 3W a massimo 18W. Il funzionamento a pulsante, permette con pressione prolungata di effettuare la regolazione mentre con pressione breve accensione e spegnimento.

**Impostazione del minimo livello di regolazione**

Vengono prodotti con impostazione di fabbrica: Min 30% - Max 100%. Qualora si volesse ridurre il minimo al 20% o al 10% agire sul pulsante di regolazione tenendolo premuto per 30s dopo questo tempo il carico si spegnerà e il minimo si imposterà automaticamente ad un livello più basso.

*Very reduced size dimmer for LED modules. The current selection takes place by the **inside jumper** (Fig. 1) with a power ranging from a minimum of 3W to a maximum of 18W. The functioning by switch allows making adjustments when pressed for long, while on/off is made with a short pressing.*

**Setting the minimum adjustment level**

*They are produced with factory setting: Min 30% - Max 100%. If you need to lower the minimum to 20% or 10% hold the adjustment push button down for 30s. When this amount of time has elapsed the load will switch off and the minimum will be automatically set at a lower level.*



Vin	Vdc	12			24		
Iout	mA	350	500	700	350	500	700
Power	W	3	5	7	8	12	18
N° LED typical VF 3,2V	min max	1÷3	1÷3	1÷3	1÷7	1÷7	1÷7

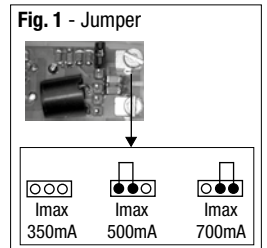
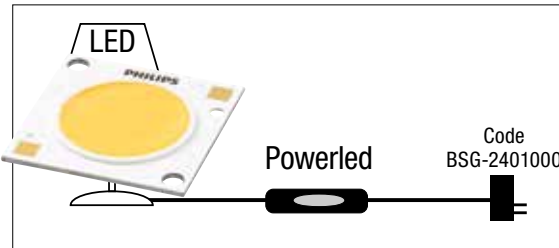

Codice Code	Colore Color	Vdc IN	W max	W min	mA	ta °C	tc °C	in	out	PCS
RL0020/LED	T	24÷48	40	2	300÷1050	35	65	0,75	0,75	12
RL0021/LED	N									



Dimmers da terra per moduli LED con comando a pulsante. La selezione della corrente o della tensione in uscita avviene tramite **Dip Switch** interno, con potenza da minimo 2W a massimo 40W. Il funzionamento a pulsante, permette con pressione prolungata di effettuare la regolazione mentre con pressione breve accensione e spegnimento.

**Impostazione del minimo livello di regolazione**

Il prodotto viene fornito con impostazione di fabbrica:

Min 30% - Max 100%.

Qualora si volesse ridurre il minimo al 20% o al 10% agire sul pulsante di regolazione tenendolo premuto per 30s dopo questo tempo il carico si spegnerà e il minimo si imposterà automaticamente ad un livello più basso.

*Floor Dimmers for LED modules, with push-button control.*

*The output current or voltage selection takes place by the **inside Dip switch** with a power ranging from a minimum of 2W to a maximum of 40W. The functioning by switch allows making adjustments when pressed for long, while on/off is made with a short pressing.*

**Setting the minimum adjustment level**

*The product is provided with factory setting:*

*Min 30% - Max 100%.*

*If you need to lower the minimum to 20% or 10% hold the adjustment push button down for 30s. When this amount of time has elapsed the load will switch off and the minimum will be automatically set at a lower level.*

Vin	Vdc	24 ÷ 48															
Iout	mA	300	350	400	450	500	550	600	650	700	750	800	850	900	950	1000	1050
Power	W	14	17	19	22	24	26	29	31	34	36	38	40	40	40	40	40
N° LED typical VF 3,2V	min max	1÷15	1÷15	1÷15	1÷15	1÷15	1÷15	1÷15	1÷15	1÷15	1÷15	1÷15	1÷14	1÷13	1÷13	1÷12	1÷11



Codice Code	Colore Color	Vdc IN	W max	Vout Vdc	W min	ta °c	tc °c	in	out	PCS
AMMINILEDN	N	24-30	48	12	1	35	65	0,75	0,75	20
450MINILEDN	N		60	24	1					

Dimmer per moduli LED di dimensioni ridotte, pari a quelle di un comune interruttore passante su filo. Adatto ad essere impiegato con strisce LED 12 e 24Vdc, la selezione della tensione avviene tramite **jumper interno** (Fig. 1), con potenza da minimo 1W a massimo 16W. Il funzionamento a pulsante, permette con pressione prolungata di effettuare la regolazione mentre con pressione breve accensione e spegnimento.

A small-sized dimmer for LED modules, similar to a standard wired switch. Suitable for use with 12 and 24Vdc LED strips, voltage selection is via an **internal jumper** (Fig. 1), with power ranging from a minimum of 1W to a maximum of 16W. The push-button operation allows a long press to adjust the light, while a short press to turn it on and off.

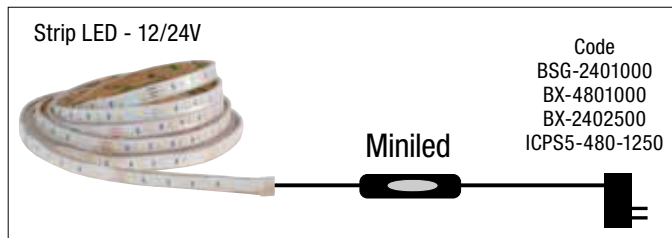

Codice Code	Colore Color	Vdc IN	mA	W max	W min	ta °c	tc °c	in	out	PCS
RL0018/LED	T	24	2500	60	2	35	65	0,75	0,75	10
		48	1250							
RL0019/LED	N	24	2500	60	2	35	65	0,75	0,75	10
		48	1250							

Dimmer per moduli led con comando a pulsante. Tipica è l'applicazione con strisce LED monocromatiche o tunable white 24V o 48V. La selezione del funzionamento avviene tramite **Dip Switch** interno, con potenza da minimo 2W a massimo 60W. Il funzionamento a pulsante, permette con pressione prolungata di effettuare la regolazione mentre con pressione breve accensione e spegnimento. Memoria d'intensità luminosa

Dimmer for LED modules, with push-button control. Typical is the application with monochromatic or tunable white 24V or 48V LED strips. The operation selection is done via an internal Dip Switch from a minimum of 2W to a maximum of 60W. The functioning by switch allows making adjustments when pressed for long, while on/off is made with a short pressing. Light intensity memory

VDT			
Vout	Vdc	24	48
Power	W	60	60

**POSSIBILITÀ DI COMANDO ON-OFF + DIM DI DUE FONTI LUMINOSE SEPARATE 24V O 48V**  
**POSSIBILITY OF ON-OFF CONTROL + DIM OF TWO SEPARATE LIGHT SOURCES 24V OR 48V**

**Esempio applicativo - Application example**

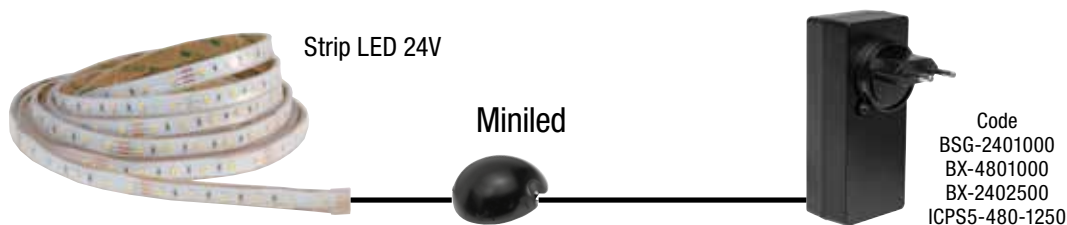

**DT MINILED PUÒ COMANDARE ANCHE STRISCE LED TUNABLE WHITE - DT MINILED CAN ALSO CONTROL TUNABLE WHITE LED STRIPS**



# LED DRIVER (DIMMER) MULTIPOWER DIM



## 6500 LED

Design: Zecca & Zecca



### Dimensioni (mm) - Dimensions (mm)

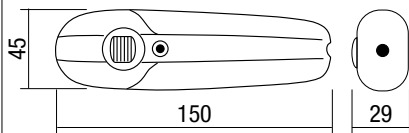

Alimentatore elettronico dimmerabile con comando rotativo, da tavolo per moduli LED a corrente costante CDT (vedi tabella). Per uso indipendente.

Table dimmable electronic power supply unit with rotary control for direct current LED modules CDT (see table). For independent use.



Codice Code	Colore Color	Vdc IN	Vac IN	Hz	THBA?	iC	ta °C	tc °C	PFC	PCS	CCM cm <sup>3</sup>
RL4697/LED	T	176-264	110-240	50/60	25	20A 170µS	30..35	85	OK	20	6.800
RL4696/LED	N	176-264	110-240	50/60	25	20A 170µS	30..35	85	OK	20	6.800

6500 LED		CDT																
Iout	mA	200	250	300	350	400	450	500	550	600	650	700	750	800	850	900	950	
Vout	Vdc	42	42	42	42	42	42	42	42	42	42	42	42	42	42	42	42	
Power	W	8	10	12	15	17 (15)	19 (15)	20 (15)	20 (15)	20 (15)	20 (15)	20 (15)	20 (15)	20 (15)	20 (15)	20 (15)	20 (15)	
N° LED typical VF 3,2V	min-max	1÷12	1÷12	1÷12	1÷12	1÷11	1÷8	1÷8	1÷8	1÷7	1÷7	1÷6	1÷6	1÷5	1÷5	1÷4	1÷4	

COB - Typical VF 37V

I valori di potenza tra parentesi sono riferiti alla tensione minima di alimentazione - The power values in brackets refer to the minimum supply voltage.



## 5500 LED

Design: Ezio Didone



### Dimensioni (mm) - Dimensions (mm)

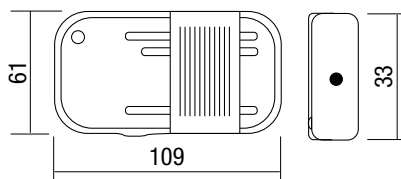

Alimentatore elettronico dimmerabile a cursore, da tavolo o pavimento per moduli LED a corrente costante CDT o tensione costante VDT (vedi tabella). Per uso indipendente.

Floor or table dimmable electronic power supply unit with cursor for constant current LED modules CDT or constant voltage VDT (see table). For independent use.



Codice Code	Colore Color	Vdc IN	Vac IN	Hz	THBA?	iC	ta °C	tc °C	PFC	PCS	CCM cm <sup>3</sup>
RL7310SILENCE	T	176-264	110-240	50/60	25	20A 170µS	0..35	85	OK	20	6.800
RL7317SILENCE	N	176-264	110-240	50/60	25	20A 170µS	0..35	85	OK	20	6.800

5500 LED		CDT										5500 LED		VDT
Iout	mA	350	400	450	500	550	600	650	700	Vout		Vdc	24	
Vout	Vdc	42	42	42	40	36.3	33.3	30.8	28.5	Power		W	16	
Power	W	15	17 (15)	19 (15)	20 (15)	20 (15)	20 (15)	20 (15)	20 (15)	COB - typical VF 37V				
N° LED typical VF 3,2V	min-max	1÷12	1÷11	1÷8	1÷8	1÷8	1÷7	1÷7	1÷6					

I valori di potenza tra parentesi sono riferiti alla tensione minima di alimentazione - The power values in brackets refer to the minimum supply voltage.

# LED DRIVER (DIMMER) MULTIPOWER DIM

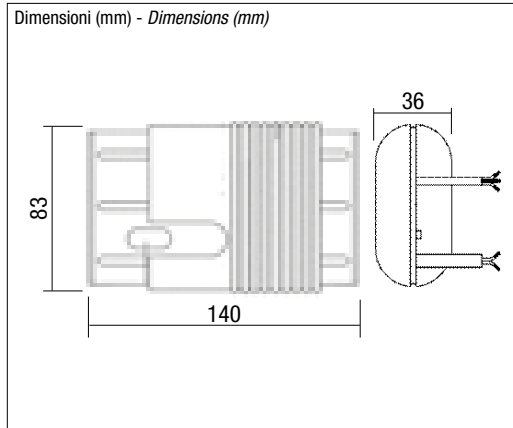

Codice Code	LPH $\downarrow \uparrow$ mm	Vdc IN	Vac IN	Hz	IP	iC	ta °C	tc °C	PFC	PCS	CCM cm <sup>3</sup>
RL4720/LED	140x88x36	176-264	110-240	50/60	25	20A 170µS	0..35	85	OK	12	6.800

7040 LED		CDT															
I <sub>out</sub>	mA	300	350	400	450	500	550	600	650	700	750	800	850	900	950	1000	1050
V <sub>out</sub>	Vdc	46	46	46	46	46	46	46	46	46	46	46	46	46	46	46	46
Power	W	14	17	19	21 (20)	24 (20)	26 (20)	28 (20)	30 (20)	32 (20)	34 (20)	36 (20)	38 (20)	40 (40)	40 (20)	40 (20)	40 (20)
N° LED typical VF 3,2V	min - max	1÷15	1÷15	1÷15	1÷15	1÷15	1÷15	1÷15	1÷14	1÷14	1÷14	1÷14	1÷14	1÷14	1÷13	1÷13	1÷12
COB - Typical VF 37V																	

I valori di potenza tra parentesi sono riferiti alla tensione minima di alimentazione - The power values in brackets refer to the minimum supply voltage.

Alimentatore elettronico dimmerabile a cursore, da pavimento per moduli LED a corrente costante CDT (vedi tabella). Per uso indipendente.

### Caratteristiche tecniche

- Alimentatore multipotenza dimmerabile fornito di dip-switch per la selezione della corrente in uscita.
- Regolazione a cursore.
- Accensione e spegnimento con interruttore.
- Alimentatore indipendente IP20, per uso interno.
- Protetto in classe II contro le scosse elettriche per contatti diretti e indiretti.
- Uscita in corrente costante (CDT).
- Protezioni: al cortocircuito, contro le extra-tensioni di rete, contro i sovraccarichi.
- Morsetti di entrata e uscita sullo stesso lato.
- CDT connessione moduli led in serie
- Colore: Nero (a richiesta colore trasparente - RL4740/LED).

Floor dimmable electronic power supply unit with cursor for direct current LED modules CDT (see table). For independent use.

### Technical features

- Dimmable multipower power supply unit equipped with a dip-switch to select the output current.
- Cursor adjustment.
- Switch on and off with switch.
- IP20 independent power supply unit, for indoor use.
- Class II protection against electric shocks by direct and indirect contact.
- Constant current output (CDT).
- Protections: against short circuit, against extra network voltage, against overloads.
- Input and output terminals on the same side.
- LED modules CDT connection in series
- Colour: Black (on request transparent colour - RL4740/LED)

### Norme di riferimento Reference norms

- EN 55015
- EN 61000-3-2
- EN 61000-3-3
- EN 61347-1
- EN 61347-2-13
- EN 61547
- EN62384

## Esempio applicativo - Application example

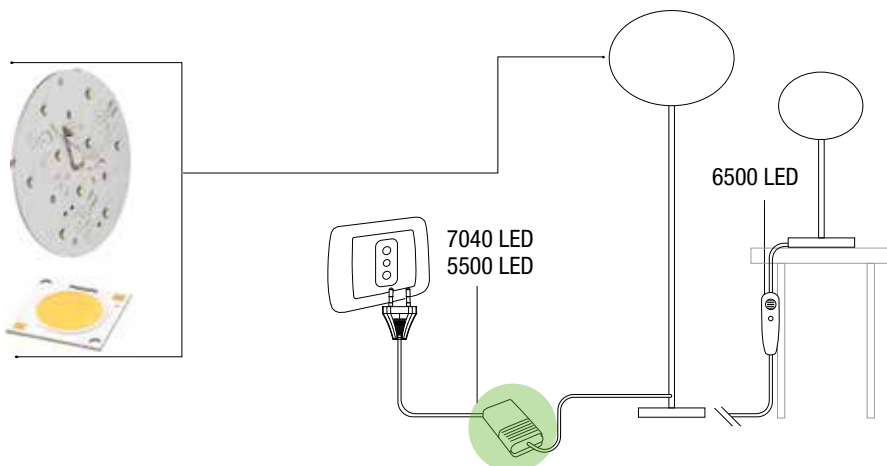

# SLIM CV LED DRIVER 48V



Alimentatore indipendente IP20 per uso interno.

Fornito di coprimorsetto e serracavo.

- Morsetti di entrata e uscita contrapposti
- Ripple di tensione:  $\pm 5\%$
- Campo di regolazione: DALI 2
- Tipo di protocollo: DALI 2
- Protezione: circuito aperto/Cortocircuito/Sovraccarico
- Protetto in classe II contro le scosse elettriche per contatti diretti e indiretti
- Temperatura ambiente:  $-20...45^{\circ}\text{C}$
- Certificati: ENEC / CCC / SAA / CB CE
- Applicazioni: striscia LED DC
- Tensione nominale: 220-240V - 50/60Hz

IP20 independent power supply for indoor use.

Supplied with terminal cover and cable clamp.

- Opposite input and output terminals
- Voltage ripple:  $\pm 5\%$
- Setting range: DALI 2
- Protocol type: DALI 2
- Protection: Open Circuit / Short Circuit / Overload
- Protected in class II against electric shocks for direct and indirect contacts
- Ambient temperature:  $-20...45^{\circ}\text{C}$
- Certificates: ENEC / CCC / SAA / CB CE
- Applications: DC LED strip
- Rated voltage: 220-240V - 50/60Hz

	Code Code	Watt Range	Output voltage Vdc	Output current mA	Input voltage Vdc	Hz			Protocol	Power factor	L (mm)	P (mm)	H (mm)
<b>NEW</b>	RN9175/48/75	75	48	0-1800mA	-	50/60	15	25A 200 $\mu\text{S}$	ON-OFF	0,95 $\lambda$	180	52	30
<b>NEW</b>	RN9175/48/120	120	48	0-2500 mA	-	50/60	15	25A 200 $\mu\text{S}$	ON - OFF	0,95 $\lambda$	300	40	30
<b>NEW</b>	RN9175/48/250	250	48	0-5210 mA	-	50/60	15	25A 200 $\mu\text{S}$	ON - OFF	0,95 $\lambda$	400	40	22

## Integrated invisible power supply 48V

- Ripple di corrente:  $\pm 5\%$
- Short time:  $<0,5\text{s} / 277\text{Vac}$
- Tc:  $-40-85^{\circ}\text{C}$
- Applicazioni: binario 48V
- Colore: Nero

- Current ripple:  $\pm 5\%$
- Short time:  $<0,5\text{s} / 277\text{Vac}$
- Tc:  $-40-85^{\circ}\text{C}$
- Applications: Track light 48V
- Colour: Black

		Code Code	Watt Range	Output voltage Vdc	Output current A	Input voltage Vdc	Hz			Power factor	L (mm)	P (mm)	H (mm)
<b>NEW</b>	<b>N</b>	RLV100W48VT3M	100	48	0-2,5	220-240	50/60	15	25A 200 $\mu\text{S}$	0,95 $\lambda$	290	15	18
<b>NEW</b>	<b>N</b>	RLV250W48VT3M	250	48	0-2,5	220-240	50/60	15	25A 200 $\mu\text{S}$	0,95 $\lambda$	258	15	44
<b>NEW</b>	<b>B</b>	RLV100W48VTWH	100	48	0-2,5	220-240	50/60	15	25A 200 $\mu\text{S}$	0,95 $\lambda$	290	15	18
<b>NEW</b>	<b>B</b>	RLV250W48VTWH	250	48	0-2,5	220-240	50/60	15	25A 200 $\mu\text{S}$	0,95 $\lambda$	258	15	44

Cavo a 4 poli (2X funzionamento ON/OFF - 2 per funzionamento DALI) - 4-pole cable (2X ON/OFF operation - 2 for DALI operation)

# FLAT CV LED DRIVER 24V



Alimentatore indipendente IP20 per uso interno.

Fornito di coprimorsetto e serracavo.

- Morsetti di entrata e uscita contrapposti
- Ripple di tensione:  $\pm 5\%$
- Protezione: circuito aperto/Cortocircuito/Sovraccarico
- Protetto in classe II contro le scosse elettriche per contatti diretti e indiretti
- Temperatura ambiente:  $-20...40^{\circ}\text{C}$
- Applicazioni: striscia LED DC
- Tensione nominale: 220-240V - 50/60Hz

*IP20 independent power supply for indoor use.*

*Supplied with terminal cover and cable clamp.*

- *Opposite input and output terminals*
- *Voltage ripple:  $\pm 5\%$*
- *Protection: Open Circuit / Short Circuit / Overload*
- *Protected in class II against electric shocks for direct and indirect contacts*
- *Ambient temperature:  $-20...40^{\circ}\text{C}$*
- *Certificates: ENEC / CCC / SAA / CB CE*
- *Applications: DC LED strip*
- *Rated voltage: 220-240V - 50/60Hz*

	Codice Code	Watt Range	Output voltage Vdc	Output current mA	Input voltage Vdc	Hz		Power factor	L (mm)	P (mm)	H (mm)
<b>NEW</b>	7064CV	8 - 40	24	333-1667 mA	220-240	50/60	10	0,95 $\lambda$	160	57,5	18

A richiesta potenze 6W - 12W - 15W - 20W - 30W - *On request powers 6W - 12W - 20W - 30W*

## Accessori non inclusi - *Not included accessories*

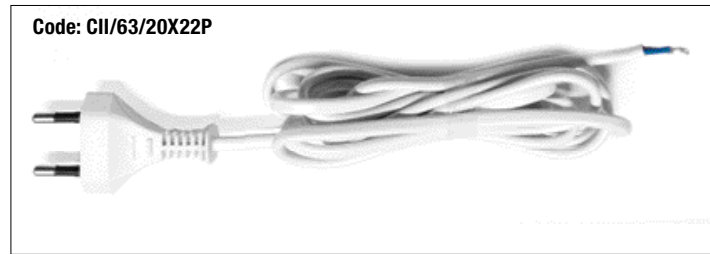
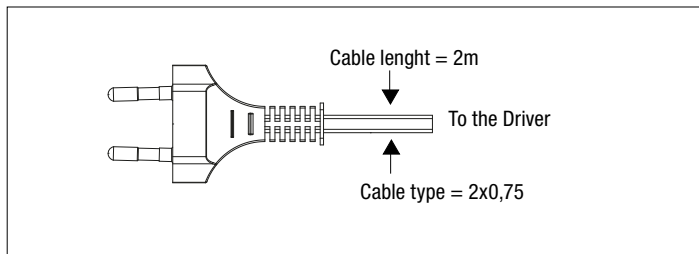
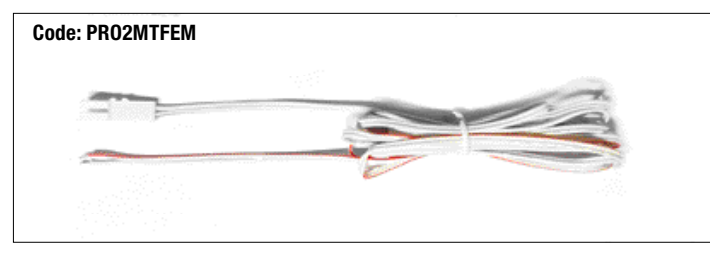
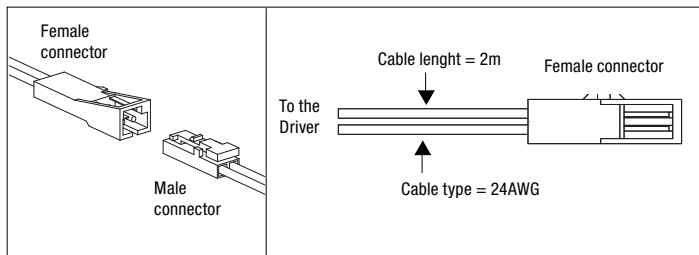
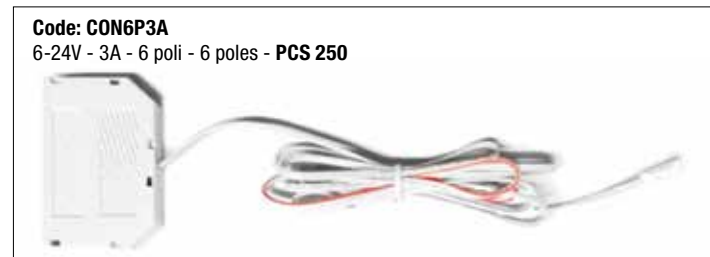
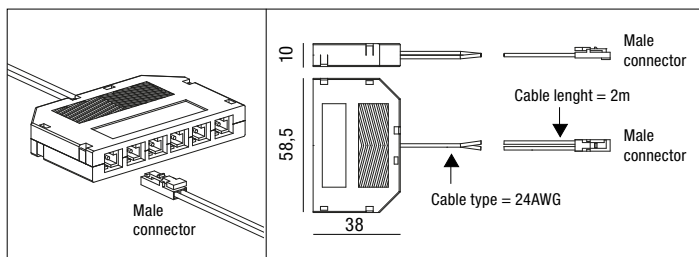

# COMPACT CV LED DRIVER 12V



Alimentatore indipendente IP20 per uso interno.  
Fornito di coprimorsetto e serracavo.

- Morsetti di entrata e uscita contrapposti
- Ripple di tensione:  $\pm 5\%$
- Campo di regolazione: 1-10V 1%-100%
- Tipo di protocollo: 1-10V
- Protezione: circuito aperto/Cortocircuito/Sovraccarico
- Protetto in classe II contro le scosse elettriche per contatti diretti e indiretti
- Temperatura ambiente:  $-20...45^{\circ}\text{C}$
- Certificati: ENEC / CCC / SAA / CB CE
- Applicazioni: striscia LED DC
- Tensione nominale: 220-240V - 50/60Hz

IP20 independent power supply for indoor use.  
Supplied with terminal cover and cable clamp.

- Opposite input and output terminals
- Voltage ripple:  $\pm 5\%$
- Setting range: 1-10V 1%-100% - DALI 2
- Protocol type: 1-10V - DALI 2
- Protection: Open Circuit / Short Circuit / Overload
- Protected in class II against electric shocks for direct and indirect contacts
- Ambient temperature:  $-20...45^{\circ}\text{C}$
- Certificates: ENEC / CCC / SAA / CB CE
- Applications: DC LED strip
- Rated voltage: 220-240V - 50/60Hz

	Codice Code	Watt Range	Output voltage Vdc	Output current	Hz			Protocol	Power factor	L (mm)	P (mm)	H (mm)	QTY	PROMO Euro Netto
	PTDC/5/12V/N	5	12	420 mA	50/60	30	10A 40 $\mu$ S	ON - OFF	*	40	42	21	2.900	1,50
	PTDCL1012VB	9	12	750 mA	50/60	30	10A 40 $\mu$ S	ON - OFF	*	145	22	22	800	3,00
	RN9014	30	12	2500 mA	50/60	25	20A 175 $\mu$ S	ON - OFF	0,95 $\lambda$	170	41	35		
	PTDC/50/12V	60	12	5000 mA	50/60	15	20A 175 $\mu$ S	ON - OFF	0,95 $\lambda$	180	52	30	2.275	5,00
	RN9175	100	12	8350 mA	50/60	15	20A 175 $\mu$ S	ON - OFF	0,95 $\lambda$	230	51	40	1.246	13,50
	RN1392	25	12 24	2100 mA 1000 mA	50/60	25	20A 175 $\mu$ S	ON - OFF	0,95 $\lambda$	145	39	28	2.416	7,00
	PTDC/80/B	50 80	12 24	4170 mA 3350 mA	50/60	15	25A 200 $\mu$ S	ON - OFF	0,95 $\lambda$	230	51	40		
	PTDCD/100	60 100	12 24	5000 mA 4170 mA	50/60	15	25A 200 $\mu$ S	1-10Vdc PUSH (SELV)	0,95 $\lambda$	230	51	40		

\* Per potenze inferiori a 24W non è richiesto dalle normative - For lower powers to 24W is not required by the regulations

# COMPACT CV IP67 LED DRIVER 12V/24V



Alimentatore indipendente IP67.

- Cavo di connessione su primario e secondario per il collegamento
- Protetto in classe I contro le scosse elettriche per contatti diretti e indiretti
- Ripple di tensione:  $\pm 5\%$
- Campo di regolazione: DALI 2
- Tipo di protocollo: DALI 2
- Temperatura ambiente:  $-20...45^{\circ}\text{C}$
- Certificati: ENEC / CCC / SAA / CB CE
- Applicazioni: striscia LED DC
- Tensione nominale: 220-240V - 50/60Hz

IP67 independent power supply.

- Connection cable on primary and secondary for connection
- Class I protected against electric shocks for direct and indirect contacts
- Voltage ripple:  $\pm 5\%$
- Setting range: DALI 2
- Protocol type: DALI 2
- Ambient temperature:  $-20...45^{\circ}\text{C}$
- Certificates: ENEC / CCC / SAA / CB CE
- Applications: DC LED strip
- Rated voltage: 220-240V - 50/60Hz

Codice Code	Watt Range	Output voltage Vdc	Output current mA	Hz			Protocol	Power factor	L (mm)	P (mm)	H (mm)	QTY	PROMO Euro Netto
RN1431/75	75	12	6250 mA	50/60	15	25A 200 $\mu\text{S}$	ON - OFF	0,95 $\lambda$	155	53	31		
RN1431	150	12	12500 mA	50/60	15	25A 200 $\mu\text{S}$	ON - OFF	0,95 $\lambda$	215	53	31	700	14,00
RN1475/24/DA	75	24	3125 mA	50/60	15	44A 288 $\mu\text{S}$		0,95 $\lambda$	131	67	33		
RN1431/24/100	100	24	4160 mA	50/60	15	44A 288 $\mu\text{S}$	ON - OFF	0,95 $\lambda$	164	53	33		
RN7726	150	24	6250 mA	50/60	15	44A 288 $\mu\text{S}$	ON - OFF	0,95 $\lambda$	138	66	34.75		
RN1227	150	24	6250 mA	50/60	15	44A 288 $\mu\text{S}$		0,95 $\lambda$	161	67	33		
RN1431/24	200	24	8330 mA	50/60	15	44A 288 $\mu\text{S}$	ON - OFF	0,95 $\lambda$	181	60	38		
RN7729	350	24	14.580 mA	50/60	15	44A 288 $\mu\text{S}$	ON-OFF	0,95 $\lambda$	218	76.5	38.5		

A richiesta potenze 30W - 60W - 250W (ON-OFF - 1-10V - DALI) - On request powers 30W - 60W - 250W (ON-OFF - 1-10V - DALI)



# COMPACT CV LED DRIVER 24V



- Ripple di tensione:  $\pm 5\%$
- Protezione: circuito aperto/Cortocircuito/Sovraccarico
- Protetto in classe II contro le scosse elettriche per contatti diretti e indiretti
- Temperatura ambiente:  $-20...45^{\circ}\text{C}$
- Certificati: ENEC / CCC / SAA / CB CE
- Applicazioni: striscia LED DC

- Voltage ripple:  $\pm 5\%$
- Protection: Open Circuit / Short Circuit / Overload
- Protected in class II against electric shocks for direct and indirect contacts
- Ambient temperature:  $-20...45^{\circ}\text{C}$
- Certificates: ENEC / CCC / SAA / CB CE
- Applications: DC LED strip

Codice Code	Watt Range	Output voltage Vdc	Output current mA	Hz	IC	IC	Protocol	Power factor	L (mm)	P (mm)	H (mm)	QTY	PROMO Euro Netto
RN1392	25	12	2100 mA	50/60	25	20A 175 $\mu\text{S}$	ON - OFF	0,95 $\lambda$	145	39	28	2.416	7,00
		24	1000 mA										
PTDC/3/24V/N	5	24	210 mA	50/60	30	10A 40 $\mu\text{S}$	ON - OFF	*	40	42	21		
RN1399	8	24	334 mA	50/60	30	10A 40 $\mu\text{S}$	ON - OFF	*	68	35	20		
PTDCL1024VB	10	24	417 mA	50/60	30	10A 40 $\mu\text{S}$	ON - OFF	*	65	35	20		
RN9124	15	24	625 mA	50/60	30	25A 200 $\mu\text{S}$	ON - OFF	*	130	45	16		
RN9015	30	24	1250 mA	50/60	25	20A 175 $\mu\text{S}$	ON - OFF	0,95 $\lambda$	153	41	32		
RN1432-24	40	24	1700 mA	50/60	25	20A 175 $\mu\text{S}$	ON - OFF	0,95 $\lambda$	185	46	38		
RN7669	50	24	2080	50/60	15	25A 200 $\mu\text{S}$	ON - OFF	0,95 $\lambda$	180	52	30		
RN1279	60	24	2500 mA	50/60	15	25A 200 $\mu\text{S}$	DALI 2	0,95 $\lambda$	250	30	21		
RN1428	60	24	2500 mA	50/60	15	10A 170 $\mu\text{S}$	ON - OFF	0,95 $\lambda$	300	30	17		
91756024-DA	60	24	1000-2500 mA	50/60	25	20A 170 $\mu\text{S}$	DALI 2	0,95 $\lambda$	300	30	15		
RN1428/KL	60	24	2500 mA	50/60	15	10A 170 $\mu\text{S}$	ON - OFF	0,95 $\lambda$	180	52	30		
RN7722	75	24	3125	50/60	15	25A 200 $\mu\text{S}$	ON - OFF	0,95 $\lambda$	180	52	30		
RN7724	100	24	4160	50/60	15	25A 200 $\mu\text{S}$	ON - OFF	0,95 $\lambda$	184	61	32		
RN9175/24	120	24	0-5000 mA	50/60	15	25A 200 $\mu\text{S}$	ON - OFF	0,95 $\lambda$	300	40	30		
917515024-DA	150	24	1875-6250 mA	50/60	15	25A 200 $\mu\text{S}$	DALI 2	0,95 $\lambda$	350	30	18		
RN7725	150	24	6250	50/60	15	25A 200 $\mu\text{S}$	ON - OFF	0,95 $\lambda$	210	37	44		
RN9175/24/180	180	24	0-7500 mA	50/60	15	25A 200 $\mu\text{S}$	ON - OFF	0,95 $\lambda$	345	50	35		
RN9175/24/200	200	24	0-8350 mA	50/60	15	25A 200 $\mu\text{S}$	ON - OFF	0,95 $\lambda$	400	40	30		

# KZQ-4 - DALI + PUSH + Phase Cut + 0-10V LED DIMMER 12÷48V



Dimensioni (mm) - Dimensions (mm)

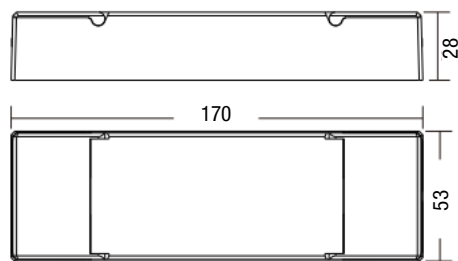

**Norme di riferimento  
Reference standard**  
EN 55015  
EN 61000-3-2  
EN 61347-1  
EN 61347-2-13  
EN 61547  
EN 62384  
EN 62396-207

Code	Input voltage	Output power	Dimming input	DALI Consumption	Dimming range	ta °C
RL-2303P	12-48Vdc	1x (240-960)W	DALI & AC Push & 0/1-10 & Phase Cut	2mA	0,1%-100%	-20.....50°

- Dimmer LED multifunzione 4 in 1 con interfaccia DALI, AC push, 0/1-10 V e multifase
- Conforme a tutti gli standard IEC 62386-101:2014, IEC 62386-102:2014 e IEC 62386-207 Ed2
- Interfaccia DALI-2 integrata, dispositivo DALI DT6
- Compatibile con tutti i sistemi DALI presenti sul mercato
- DIP switch per la selezione di diverse interfacce dimmer
- Alimentazione 12-48 VDC su 1 canale, max. 20 A
- Supporta la penetrazione di fase ascendente e discendente
- 1 DALI assegnato al master DALI
- Compatibile con dimmer universali a taglio di fase
- Utilizzare un potenziometro per aumentare la potenza a piacere indefinitamente.
- 4-in-1 multifunction LED dimmer with DALI interface, AC push, 0/1-10 V, and multiple phases
- Complies with all standards IEC 62386-101:2014, IEC 62386-102:2014, and IEC 62386-207 Ed2
- Integrated DALI-2 interface, DALI device DT6
- Compatible with all DALI systems on the market
- DIP switches for selecting different dimmer interfaces
- Power supply 12-48 VDC on 1 channel, max. 20 A
- Supports up- and down-phase penetration
- 1 DALI assigned to the DALI master
- Compatible with universal phase cutting dimmers
- Use a potentiometer to expand the power as desired indefinitely.

## Avvertenze di sicurezza

- NON È POSSIBILE selezionare l'incidenza della luce se il dispositivo è accessibile.
- L'installazione NON deve essere eseguita mentre il dispositivo è alimentato.
- Il dispositivo non deve essere lanciato in aria.

## Funzione

DIP switch per la selezione dell'ingresso dimmer  
Innanzitutto, selezionare l'interfaccia di ingresso del dimmer utilizzando un DIP switch nella base del sistema di controllo utilizzato. Non è possibile cablare e utilizzare contemporaneamente diverse interfacce dimmer. È possibile cablare singolarmente fino a 4 volt.

### DALI è assegnato al master DALI.

Selezionare il dimmer di ingresso DALI; l'indicatore DALI può essere assegnato automaticamente al controller master DALI. Per le procedure operative specifiche, fare riferimento al Manuale di compatibilità Master DALI.

## Safety Warnings

- You CANNOT select the light incidence if the device is accessible.
- Installation must NOT be performed while the device is energized.
- The device must not be thrown into the air.

## Function

DIP Switch for Input Dimmer Selection  
First, select the dimmer input interface using a DIP switch in the base of the control system used. It is not possible to wire and use different interface dimmers simultaneously. Individual wiring of up to 4 volts is possible.

### DALI is assigned to the DALI master.

Select the DALI input dimmer; the DALI indicator can be automatically assigned to the DALI master controller. For specific operating procedures, refer to the Master DALI Compatibility Manual.

# KZQ-4 - DALI + PUSH + Phse Cut + 0-10V LED DIMMER

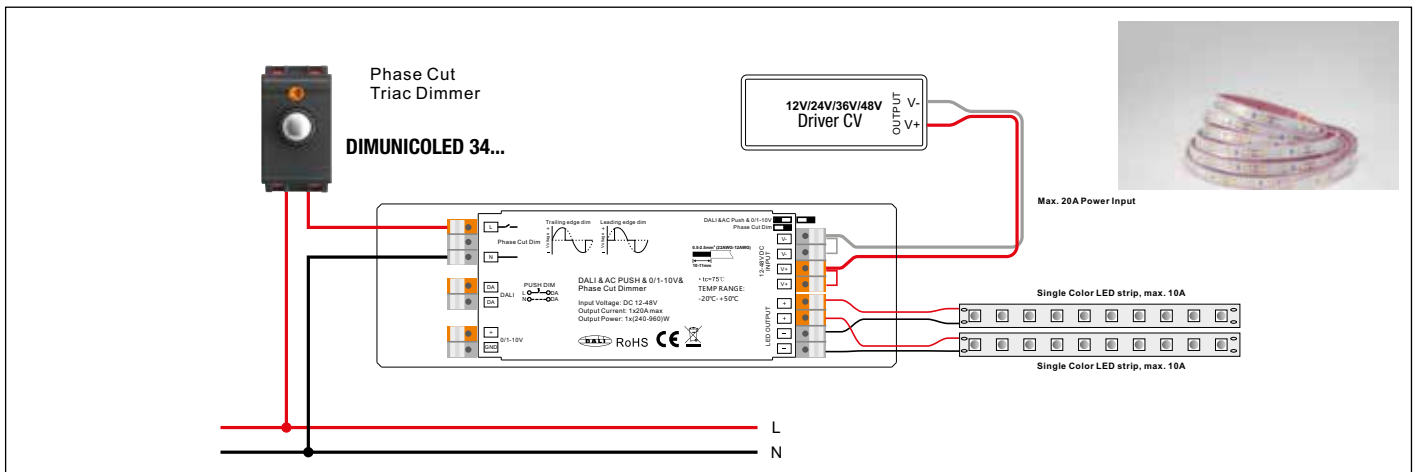
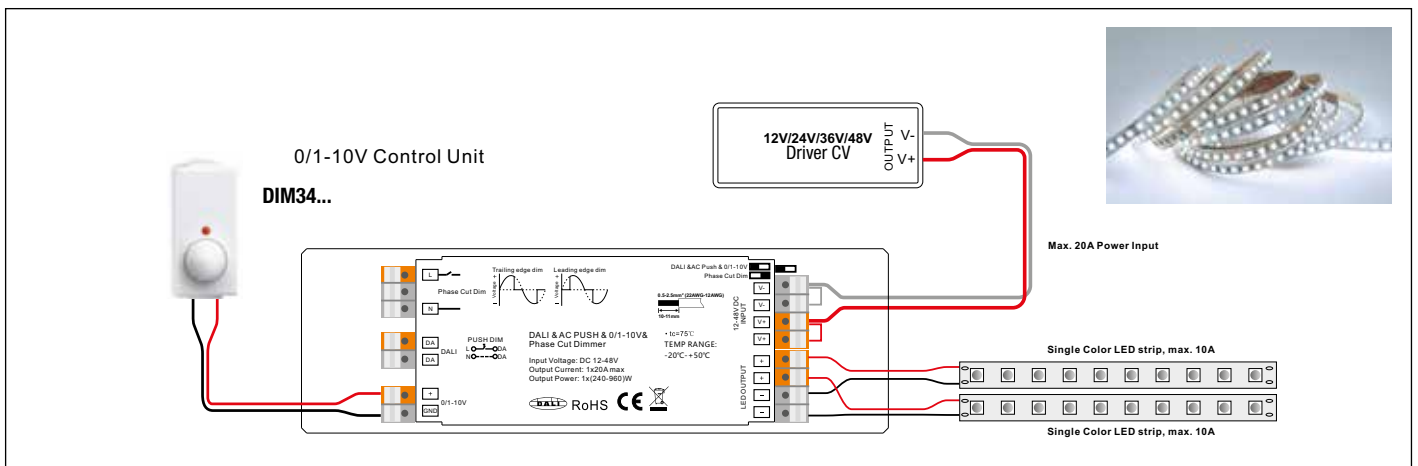
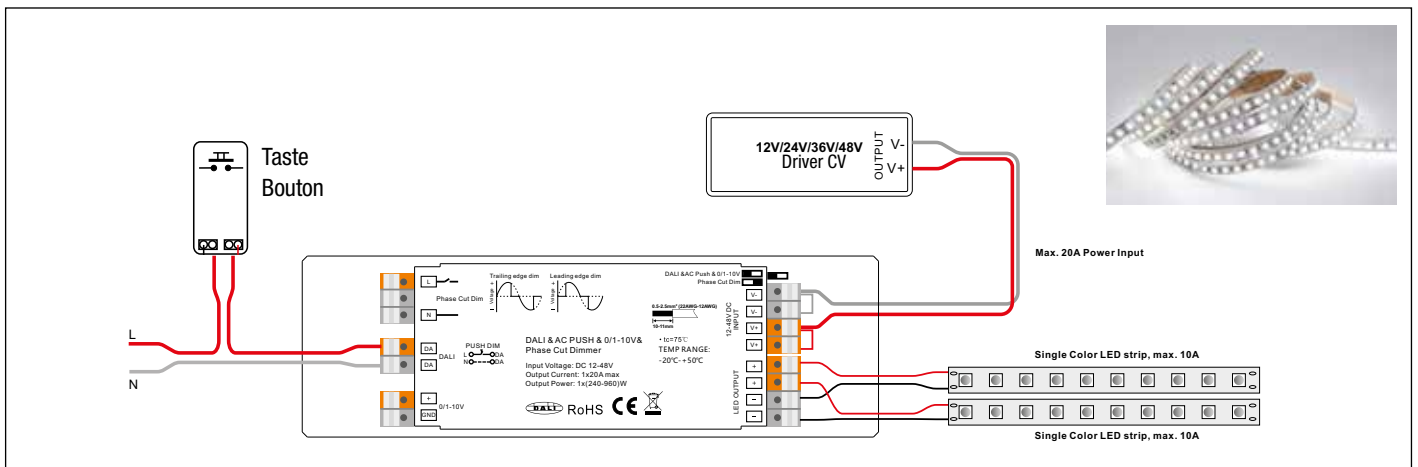
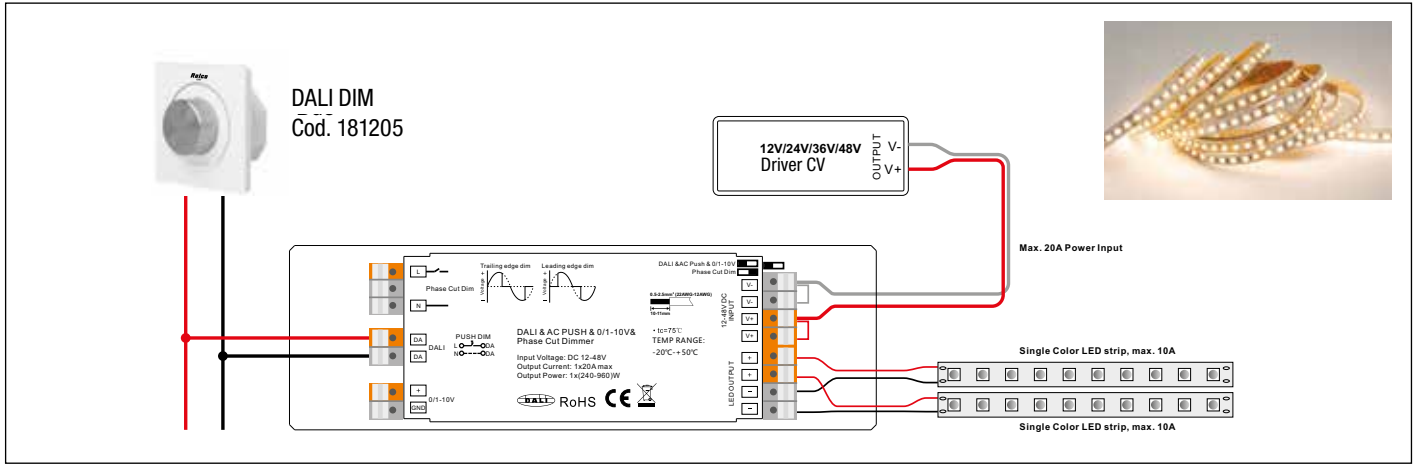

# Dimmer PUSH

Potenzimetro DALI per scatola tonda, montaggio a parete.  
*DALI power potentiometer for round box, flush mounting.*

Articolo Article	DALI DALI Type	Consumo di energia Power consumption	Corrente in uscita Output current	ta	Peso Weight	Codice Code
		<b>W</b>	<b>mA</b>	<b>°C</b>	<b>Kg</b>	
SR-2400 RB	Type 6	max. 2,3	max. 100	0...+50	0,215	181205



**Tensione Nominale**  
**Rated Voltage**  
 100 ÷ 240 V

**Frequenza**  
**Frequency**  
 50-60 Hz

**Consumo di energia**  
**Power consumption**  
 max. 2,3 W

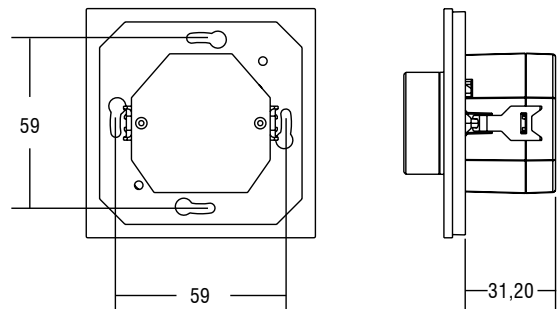

**Regolazione Dali, impianto tradizionale + due fili - Dali regulation, traditional system + two wires**

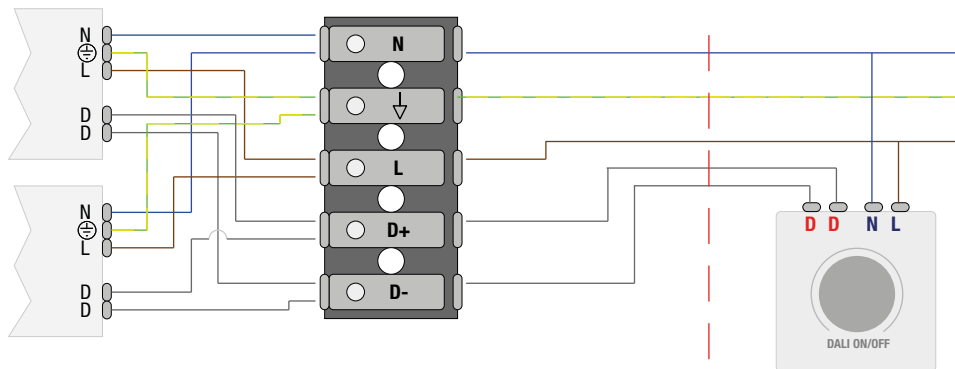

## Caratteristiche

- Progettato per funzionare con sistemi DALI-2.
- Unità di controllo DALI con alimentatore integrato.
- Consente un controllo della luminosità (trasmissione) sino ad un massimo di **50 drivers** senza alimentazione supplementare.
- Collegamento in parallelo di fino a **quattro potenziometri DALI** sino ad un massimo di **100 punti DALI**.
- Lunghezza del cavo di comunicazione DALI: max. 300 metri.
- L'utilizzo di ulteriore potenza potis DALI come estensione (senza il collegamento all'alimentazione integrata).
- Accensione e dimmerazione premendo e girando il pulsante di funzionamento.
- Memorizzazione della luminosità dimpostata e dell'ultima luminosità impostata.

## Features

- Designed to work with DALI-2 systems.
- DALI control unit with integrated power supply.
- Allows a common brightness control (broadcast) of up to **50 DALI drivers** without additional DALI power supply.
- Parallel switching of up to **four DALI power potis** extends the maximum number of **DALI stations to 100**.
- DALI communication cable length: max. 300 mt.
- Use of further DALI power potis as extension (without connection of the integrated power supply).
- Switching and dimming by pressing and turning the operation button.
- Storing of basic brightness and switch-on brightness.



## Installazione - Installation

Schema di collegamento con 2 MCU alimentati da rete CA per controllare fino a 100 ECG DALI  
 Wiring diagram with 2 MCUs powered by AC mains to control up to 100 DALI ECG

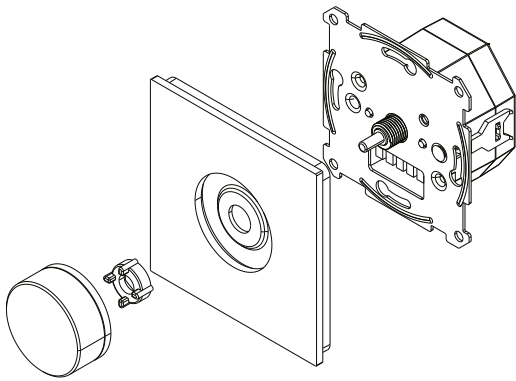

Schema di collegamento - Wiring diagram

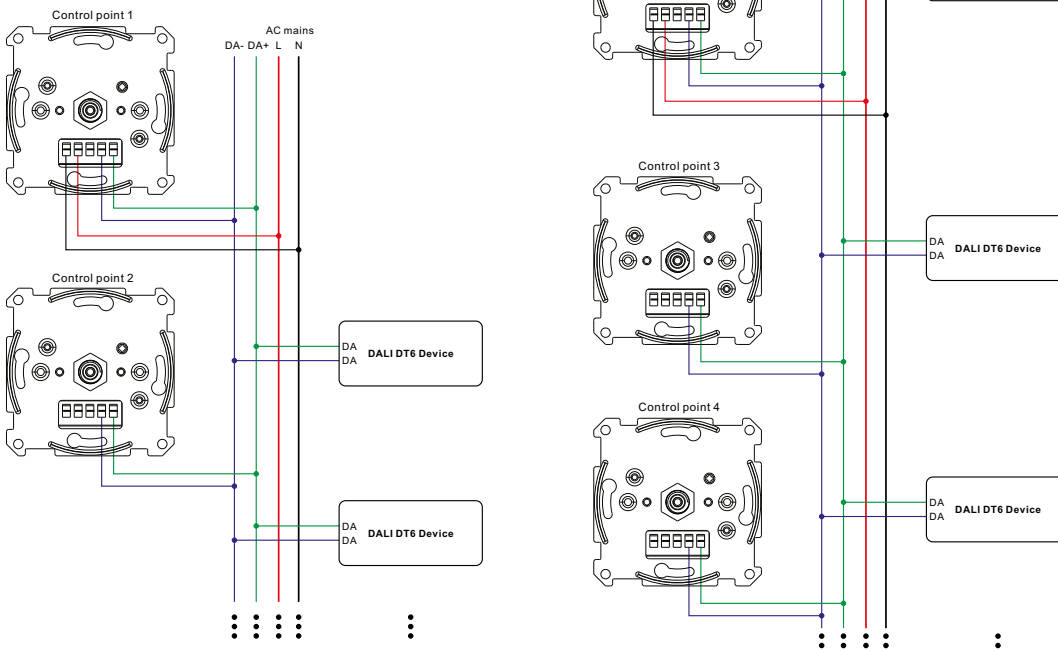

- 1 - To control up to 100 ECG with the setup, there is 2 MCUs connect to AC 220V mains
- 2 - To connect up to 50 ECG with the setup, there is only 1 MCU connect to AC 220V mains, the other MCUs powered by DALI bus. There can be max 2 MCUs connected to the AC mains in the same control circuit. It's suggested to have max 4 MCUs totally in the same control circuit.
- 1 - Per controllare fino a 100 ECG con il sistema, sono necessari 2 MCU collegati alla rete elettrica a 220 V CA.
- 2 - Per collegare fino a 50 ECG con il sistema, è necessario solo 1 MCU collegato alla rete elettrica a 220 V CA, mentre gli altri MCU sono alimentati tramite bus DALI. È possibile collegare al massimo 2 MCU alla rete elettrica CA nello stesso circuito di controllo. Si consiglia di collegare al massimo 4 MCU in totale nello stesso circuito di controllo.

# CONTROLLER SERIES

**Code: AD010**

**Interruttore elettronico ad infrarossi attivi:** AD010, è un interruttore elettronico ad infrarossi attivi adatto al comando di sorgenti luminose a led con alimentazione a 12 o 24Vdc., consente l'accensione e lo spegnimento del carico semplicemente oscurando il sensore.

**Active infra-red electronic switch:** AD010, is an electronic active infrared switch suitable for the control of 12 or 24Vdc LED light sources. It allows the switching on and off of the load simply by obscuring the sensor.

<b>Tensione di ingresso - Input voltage</b>	<b>12Vdc or 24Vdc</b>
<b>Campo di rilevamento - Detection range</b>	< 10cm
<b>Stand by</b>	< 0,2W
<b>Durata - Life time</b>	> 30.000 h
<b>Potenza - Power</b>	96W (12V) or (24V) max
<b>Corrente - Current</b>	8A max (12V) - 4A max (24V)
<b>Angolo di rilevamento - Detection beam angle</b>	120°
<b>Dimensioni - Dimensions</b>	50x10x8 mm
<b>Applicazione - Working environment</b>	Interni - Indoor
<b>Fissaggio - Fixing</b>	Con nastro bi-adesivo (NON fornito) - With double-sided tape (NOT included)
<b>Collegamento - Connection</b>	PAD a saldare - Soldering PAD

Schema di collegamento - Wiring diagram

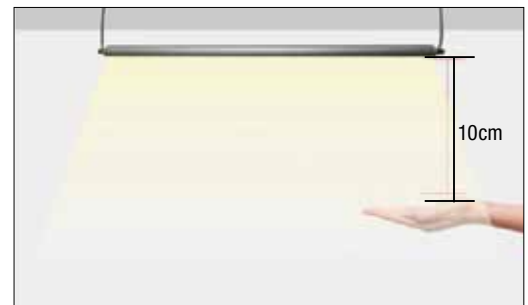
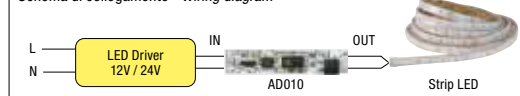

**Esempio applicativo**

Passare la mano vicino al sensore per accendere la luce

Passare nuovamente la mano vicino al sensore per spegnere la luce

**Application example**

Move hand before the detector the first time: lamp turn on

Move hand before the detector the second time: lamp turn off

**Code: AD011**

**Dimmer a pulsante:** AD011, è un dimmer con comando a pulsante adatto al comando di sorgenti luminose a led con alimentazione a 12 o 24 Vdc.

**Push-button control:** AD011, is a dimmer with button control suitable for the control of LED light sources with 12 or 24 Vdc power supply.

<b>Tensione di ingresso - Input voltage</b>	<b>12Vdc or 24Vdc</b>
<b>Memoria - Memory function</b>	SI - YES
<b>Stand by</b>	< 0,2W
<b>Durata - Life time</b>	> 30.000 h
<b>Potenza - Power</b>	96W (12V) or (24V) max
<b>Corrente - Current</b>	8A max (12V) - 4A max (24V)
<b>Range di regolazione - Dimming range</b>	5÷100%
<b>Dimensioni - Dimensions</b>	46x10x6 mm
<b>Applicazione - Working environment</b>	Interni - Indoor
<b>Fissaggio - Fixing</b>	Con nastro bi-adesivo (NON fornito) - With double-sided tape (NOT included)
<b>Collegamento - Connection</b>	PAD a saldare - Soldering PAD

Schema di collegamento - Wiring diagram

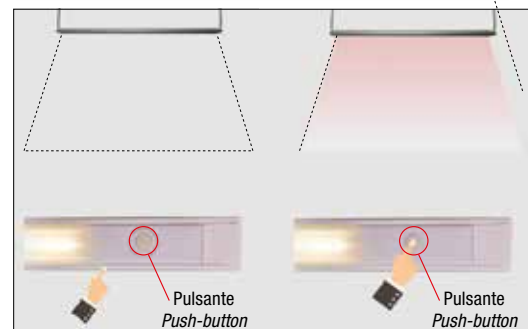
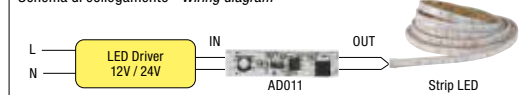

La regolazione avviene tramite il pulsante a bordo della scheda, con una pressione breve si ottiene l'accensione o lo spegnimento, pressione prolungata si avrà la regolazione.

The adjustment takes place through the button on the board, with a short press you get the turning on or off, a long press you will have the adjustment.

**Code: AD003**

**Dimmer sensoriale:** AD003, è un dimmer con comando sensoriale adatto al comando di sorgenti luminose a led con alimentazione a 12 o 24 Vdc.

**Touch dimmer:** AD003, is a dimmer with touch control suitable for controlling LED light sources with 12 or 24 Vdc power supply.

<b>Tensione di ingresso - Input voltage</b>	<b>12Vdc or 24Vdc</b>
<b>Memoria - Memory function</b>	NO
<b>Stand by</b>	< 0,2W
<b>Durata - Life time</b>	> 30.000 h
<b>Potenza - Power</b>	30W (12V) or 60W (24V) max
<b>Corrente - Current</b>	5A max
<b>Range di regolazione - Dimming range</b>	0÷100%
<b>Dimensioni - Dimensions</b>	50x10x11 mm
<b>Applicazione - Working environment</b>	Interni - Indoor
<b>Fissaggio - Fixing</b>	Con nastro bi-adesivo (NON fornito) - With double-sided tape (NOT included)
<b>Collegamento - Connection</b>	PAD a saldare - Soldering PAD

Schema di collegamento - Wiring diagram

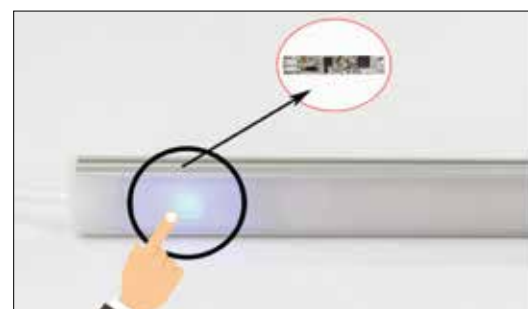

La regolazione avviene tramite il contatto sensoriale presente sulla scheda, con un tocco breve si ottiene l'accensione o lo spegnimento, con un tocco prolungato si avrà la regolazione.

The adjustment takes place through the sensorial contact present on the board, with a short touch you can switch it ON or OFF, with a prolonged touch you will have the adjustment.

# Varialuce per lampade LED dimmerabili

## Dimmer for dimmable LED lamps



# VARIALUCE LED PASSANTE DA FILO - CORDSET LED DIMMER

Per lampade LED dimmerabili - For dimmable LED bulbs



Comando a pulsante - Push-button control

## SNELLO LED

Varialuce per lampade LED o alogene in classe II

- Comando a pulsante
- Grado di protezione IP20.
- Grado di inquinamento 2.
- Tensione di tenuta ad impulso (2,5kV).
- Indice di resistenza alle correnti superficiali (PTI175).
- Livello della prova del filo incandescente: 650°C (interruttore di livello 1).
- Regolazione continua
- STOP al massimo, STOP al minimo
- Accensione graduale (antiabbagliamento)
- Spegnimento graduale
- Installazione passante sul cavo di alimentazione
- Tipo di servizio: continuo.
- Punto luminoso per l'individuazione al buio
- Fusibile incorporato (T 800mA H 250V ~)
- Memoria d'intensità luminosa anche in assenza di rete.
- Assenza di ronzio acustico e vibrazione.
- Per lampade LED dimmerabili delle migliori marche in commercio.
- Morsetti di collegamento destinati alla connessione di conduttori flessibili preparati.

Trailing edge technolog

## Electronic light dimmer for LED or halogen lamps

- Push button control
- Pollution degree of 2.
- Impulse withstand voltage (2,5kV).
- Resistance index to surface current (PTI175).
- Incandescent wire test level: 650°C (level 1 switch).
- Continued regulation
- STOP at maximum, STOP at minimum
- Soft start (anti-glare)
- Soft stop
- Cable loop installation
- Light for easy finding in the dark
- Fuse incorporated (T 800mA H 250V ~)
- The light level is memorized unless the mains supply is cut off
- Possibility to switch on by wall dimmer
- For dimmable LED lamps from major producers
- Terminals intended for connection of flexible conductors prepared.

Trailing edge technolog



	W min. max	V	Hz	LPH mm	☀	set. min	PCS	CCM cm <sup>3</sup>
LED	4÷100 *	220-240	50/60	22x83x22	●	SI	20	6.800
	4÷80 *	110-127						
HALO	25÷160	220-240	50/60	22x83x22	●	SI		
	25÷80	110-127						

\* Max 10 lampadine LED - Max 10 LED lamps



SNELLO LED N  
Cod. RL7150/LED



SNELLO LED B  
Cod. RL7155/LED



SNELLO LED P  
Cod. RL7160/LED



SNELLO LED T  
Cod. RL7165/LED

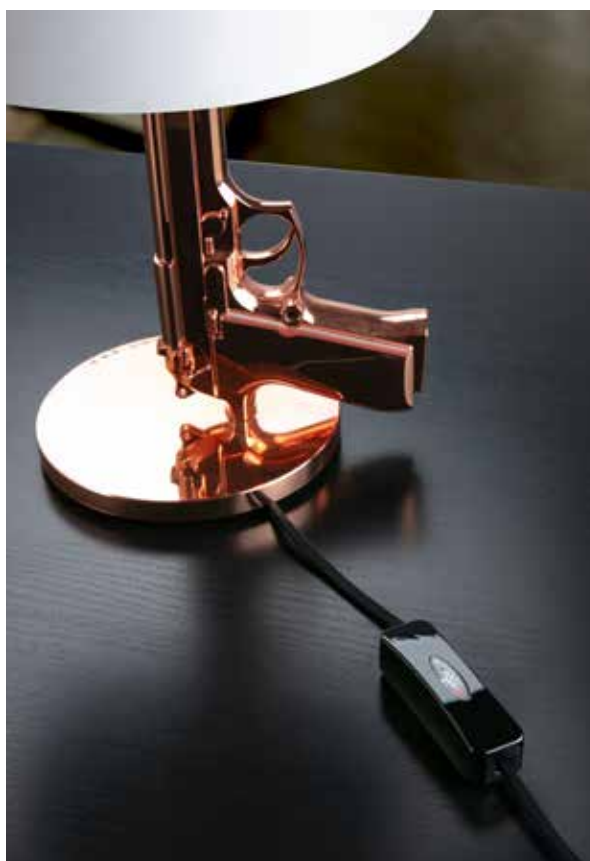

SNELLO LED N



SNELLO LED B



SNELLO LED P



SNELLO LED T

**Cablaggio:** spina bipolare europea (2.5A 250V) e cavo piatto 2x0,75 mm<sup>2</sup> H03VVH2-F o cavo tondo H03VV-F 2x075 mm.

**A richiesta per quantità** cablaggio di lunghezza diversa).

**Cordset with:** double pole Euro-plug (2.5A 250V) and flat cable 2x0,75 mm<sup>2</sup> H03VVH2-F or round cable H03VV-F 2x075 mm.

**On demand for quantity:** wiring of different lengths).

## Impostazione minimo Setting minimum

Consente di scegliere tre livelli di minimo lampada.

Allows you to select three levels of minimum lamp.

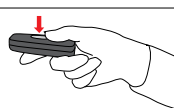

Mantenere premuto il pulsante per 30 sec.  
Hold down the button for 30 seconds.



Carico acceso  
Load ON

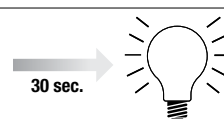

30 sec.

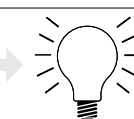

Dopo 30 sec il carico si spegne  
After 30 sec. the load is switched OFF

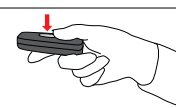

Premere nuovamente il pulsante e verificare il minimo  
Press the button again and check the minimum

# VARIALUCE LED PASSANTE DA FILO - CORDSET LED DIMMER

Per lampade LED dimmerabili - For dimmable LED bulbs



Comando a pulsante - Push-button control



**Cablaggio:** spina bipolare europea (2.5A 250V) e cavo piatto 2x0,75 mm<sup>2</sup> H03VVH2-F, o cavo tondo H03VV-F 2x075 mm.

**A richiesta per quantità** cablaggio di lunghezza diversa).

**Cordset with:** double pole Euro-plug (2.5A 250V) and flat cable 2x0,75 mm<sup>2</sup> H03VVH2-F or round cable H03VV-F 2x075 mm.

**On demand for quantity:** wiring of different lengths).

	W <small>min. max.</small>	V	Hz	LPH <small>mm</small>			PCS	CCM cm <sup>3</sup>
LED	4÷100 *	220-240	50/60	22x83x22	NO	SI	20	6.800
	4÷80 *	110-127						
HALO	25÷80	220-240	50/60	22x83x22	NO	SI	20	6.800
	25÷50	110-127						



Cod: AMLEDN



Cod. AMLEDP



Cod. AMLEDB



Cod. AMLEDT

## AM LED

Varialuce per lampade LED o alogene in classe II

- Comando a pulsante
- STOP al massimo, STOP al minimo
- Accensione graduale (antiabbagliamento)
- Spegnimento graduale
- Installazione passante sul cavo di alimentazione.
- Fusibile incorporato (T 800mA H 250V ~)
- Per lampade LED dimmerabili delle migliori marche in commercio.

## Trailing edge technolog

Electronic light dimmer class II for LED or halogen lamps

- Push button control
- STOP at maximum, STOP at minimum
- Soft start (anti-glare)
- Soft stop
- Cable loop installation
- Fuse incorporated (T 800mA H 250V ~)
- For dimmable LED lamps from major producers

## Impostazione minimo - Setting minimum

Consente di scegliere tre livelli di minimo lampada - Allows you to select three levels of minimum lamp.

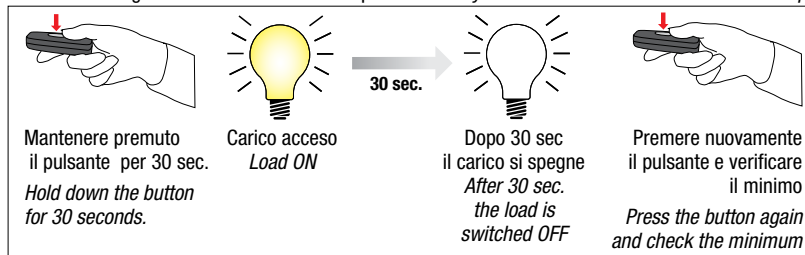

**Cablaggio:** spina bipolare europea (2.5A 250V) e cavo piatto 2x0,75 mm<sup>2</sup> H03VVH2-F, o cavo tondo H03VV-F 2x075 mm.

**A richiesta per quantità** cablaggio di lunghezza diversa).

**Cordset with:** double pole Euro-plug (2.5A 250V) and flat cable 2x0,75 mm<sup>2</sup> H03VVH2-F or round cable H03VV-F 2x075 mm.

**On demand for quantity:** wiring of different lengths).

	W <small>min. max.</small>	V	Hz	LPH <small>mm</small>			PCS	CCM cm <sup>3</sup>
LED	4÷100 *	220-240	50/60	22x83x22	NO	SI	20	6.800
	4÷80 *	110-127						
HALO	25÷80	220-240	50/60	22x83x22	NO	SI	20	6.800
	25÷50	110-127						



Cod: ACHILLE450N



Cod. ACHILLE450P



Cod. ACHILLE450B



Cod. ACHILLE450T

## ACHILLE 450 LED

Varialuce per lampade LED o alogene in classe II

- Comando a pulsante
- STOP al massimo, STOP al minimo
- Accensione graduale (antiabbagliamento)
- Spegnimento graduale
- Installazione passante sul cavo di alimentazione.
- Fusibile incorporato (T 800mA H 250V ~)
- Per lampade LED dimmerabili delle migliori marche in commercio.

## Trailing edge technolog

Electronic light dimmer class II for LED or halogen lamps

- Push button control
- STOP at maximum, STOP at minimum
- Soft start (anti-glare)
- Soft stop
- Cable loop installation
- Fuse incorporated (T 800mA H 250V ~)
- For dimmable LED lamps from major producers

## Impostazione minimo - Setting minimum

Consente di scegliere tre livelli di minimo lampada - Allows you to select three levels of minimum lamp.

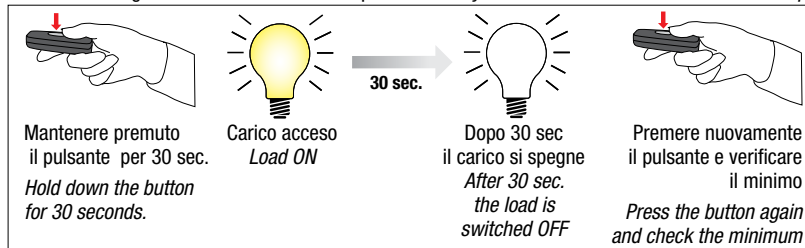

# VARIALUCE LED PASSANTE DA FILO - CORDSET LED DIMMER

Per lampade LED dimmerabili - For dimmable LED bulbs



Design: Ezio Didone

Comando a cursore - Slide control

## RONDÓ LED

Varialuce da tavolo o pavimento per lampade LED o alogene in classe II

- Regolatore elettronico per lampade alogene e lampade LED dimmerabili 100-240V;
- Grado di inquinamento 2;
- Indice di resistenza alle correnti superficiali (PTI175);
- Livello della prova del filo incandescente (interruttore di livello 1);
- Tipo di servizio: S1 (tipo continuo)
- Installazione passante sul filo;
- Interruttore incorporato;
- Fusibile incorporato;
- Potenza con alimentazione 220-240V~:
  - Carico interrotto 4 fili: 0÷440W (220-240V~) - 0÷200W (100-127V~)
- Campo di temperatura ambiente di funzionamento 0-35 °C;
- Il dimmer è dotato di interruttore di tipo meccanico che garantisce una disconnessione di tipo completo su un carico, e una regolazione di intensità che garantisce soltanto una disconnessione di tipo elettronico nell'altro carico (ε)
- Per lampade LED dimmerabili delle migliori marche in commercio.

### Trailing edge technology

Electronic table or floor light dimmer for LED or halogen lamps

- Electronic dimmer suitable for 100-240V halogen lamps and dimmerable LED lamps;
- Pollution degree of 2;
- Resistance index for superficial currents (PTI175);
- Test level of the incandescent wire (level 1 switch);
- Type of operation: S1 (continuous type)
- Pass through installation on the wire;
- Built-in switch;
- Built-in fuse;
- 4-wire interrupted load :
  - 0÷440W (220-240V~) - 0÷200W (100-127V~)
- Ambient temperature operating range 0-35°C;
- The dimmer is fitted with a mechanical switch that ensures a complete disconnection on a load, and an intensity adjustment that ensures only an electronic disconnection in the other load (ε)
- For dimmable LED lamps from major producers

### Trailing edge technology

### Tipo di cavi compatibili - Compatible cables

piatto / flat	H03VVH2 - F 2x0.75mm
tondo/ round	H03VV-F 2x075 mm H03VV-F F 2x-3x0.75 mm

Vac	DIM	ON/OFF
220-240V	4÷100W (LED)	0÷440W
	4÷250W (HALO)	
100-127V	4÷100W (LED)	0÷200W
	10÷150W (HALO)	



Jumper

Selezione tramite Jumper per la gestione di una o due fonti luminose.

Selectable via Jumper for operating one or two light sources.



	W min. max.	V	Hz	LPH mm	☀	⚙ set. min	PCS	CCM m³
LED	4÷100 *	100-240	50/60	Ø 94x37	NO	NO	10	6.800
HALO	40÷250	220-240	50/60	Ø 94x37	NO	NO		
	10÷150	100-127						

\* Max 10 lampadine LED - Max 10 LED lamps



RONDÓ N LED

Cod. RS5600/LED (50pz)  
Cod. RL5600/LED (10 pz)



RONDÓ P LED

Cod. RL1205/LED (10 pz)



RONDÓ B LED

Cod. RL5618/LED (10 pz)



RONDÓ T LED

Cod. RS5640/LED (50pz)  
Cod. RL5640/LED (10 pz)

**Funzionamento 3 fili** - una fonte luminosa. L'accensione e lo spegnimento della fonte luminosa avvengono a pressione con l'interruttore, la regolazione avviene direttamente sul cursore.

**3-wire operation** - one light source. The light source is switched on and off when the switch is pressed, it is adjusted directly by the slider;

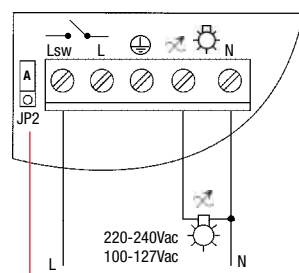

JP2 posizione "A" - JP2 position "A"  
Funzionamento una fonte luminosa  
Operation of a light source  
1) On/Off e regolazione - On/Off and dimming



**Funzionamento 4 fili** - due fonti luminose. L'accensione e lo spegnimento della fonte luminosa avvengono a pressione con l'interruttore, la regolazione avviene direttamente sul cursore; in prossimità del valore minimo di regolazione il regolatore spegne automaticamente il carico.

**4-wire operation** - two light sources. The light source is switched on and off when the switch is pressed, it is adjusted directly by the slider; when the dimmer nears the minimum adjustment value, it automatically switches the load off.

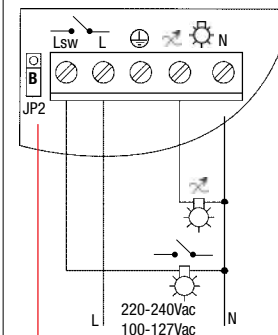

JP2 posizione "B" - JP2 position "B"  
Funzionamento due fonti luminose - Operation of two light sources  
JP2 1) On/Off e 2)Regolazione - Dimming



# VARIALUCE LED PASSANTE DA FILO - CORDSET LED DIMMER

Per lampade LED dimmerabili - For dimmable LED bulbs



Comando a cursore - Slide control

Vac	DIM	ON/OFF
220-240V	4÷100W (LED)	0÷440W
	4÷250W (HALO)	
100-127V	4÷100W (LED)	0÷200W
	10÷150W (HALO)	

	W min. max.	V	Hz	LPH mm	Sun	set. min	PCS	CCM m <sup>3</sup>
LED	4÷100 *	100-240	50/60	Ø 94x37	NO	NO	10	6.800
HALO	40÷250 10÷150	220-240 100-127	50/60	Ø 94x37	NO	NO		

\* Max 10 lampadine LED - Max 10 LED lamps



Selezione tramite Jumper per la gestione di una o due fonti luminose.  
Selectable via Jumper for operating one or two light sources.

**Cablaggio:** spina bipolare europea (2.5A 250V) e cavo piatto 2x0,75 mm<sup>2</sup> H03VVH2-F o cavi tondi H03VV-F 2x075 mm, H03VV-F F 2x-3x0.75 mm.

**Cordset with:** double pole Euro-plug (2.5A 250V) and flat cable 2x0,75 mm<sup>2</sup> H03VVH2-F or round cables H03VV-F 2x075 mm, H03VV-F F 2x-3x0.75 mm.

**NEW 2026**



Cod. JJLEDN



Cod. JJLEDP



Cod. JJLEDB



Cod. JJLEDT

## JJ LED

Varialuce da tavolo o pavimento per lampade LED o alogene in classe II

- Regolatore elettronico per lampade alogene e lampade LED dimmerabili 100-240V;
- Installazione passante sul filo;
- Interruttore incorporato;
- Fusibile incorporato;
- Per lampade LED dimmerabili delle migliori marche in commercio.

## Trailing edge technology

Electronic table or floor light dimmer class II for LED or halogen lamps

- Electronic dimmer suitable for 100-240V halogen lamps and dimmerable LED lamps;
- Through-wire installation
- Built-in switch;
- Built-in fuse;
- For dimmable LED lamps from major producers

# VARIALUCE LED PASSANTE DA FILO - CORDSET LED DIMMER

Per lampade LED dimmerabili - For dimmable LED bulbs



Comando a pulsante - Push-button control



**Cablaggio:** spina bipolare europea (2.5A 250V) e cavo piatto 2x0,75 mm<sup>2</sup> H03VVH2-F, o cavo tondo H03VV-F 2x075 mm.

**A richiesta per quantità** cablaggio di lunghezza diversa).

**Cordset with:** double pole Euro-plug (2.5A 250V) and flat cable 2x0,75 mm<sup>2</sup> H03VVH2-F or round cable H03VV-F 2x075 mm.

**On demand for quantity:** wiring of different lengths).

	W min. max.	V	Hz	LPH mm	Sun	set. min	PCS	CCM cm <sup>3</sup>
LED	4÷100 *	220-240	50/60	45x85x25	NO	SI	20	6.800
	4÷80 *	110-127						
HALO	25÷80	220-240	50/60	45x85x25	NO	SI	20	6.800
	25÷50	110-127						

\* Max 10 lampadine LED - Max 10 LED lamps

**NEW 2026**



Cod. ACHIL661-100N



Cod. ACHIL661-100P



Cod. ACHIL661-100B



Cod. ACHIL661-100T

## ACHILLE 661-100 LED

Varialuce per lampade LED o alogene in classe II

- Possibilità di cablaggio anche in Classe I

- Comando a pulsante
- STOP al massimo, STOP al minimo
- Accensione graduale (antiabbagliamento)
- Spegnimento graduale
- Installazione passante sul cavo di alimentazione.
- Fusibile incorporato (T 800mA H 250V ~)
- Per lampade LED dimmerabili delle migliori marche in commercio.

## Trailing edge technology

Electronic light dimmer class II for LED or halogen lamps

- Possibility of wiring also in Class I

- Push button control
- STOP at maximum, STOP at minimum
- Soft start (anti-glare)
- Soft stop
- Cable loop installation
- Fuse incorporated (T 800mA H 250V ~)
- For dimmable LED lamps from major producers

## Trailing edge technology

### Impostazione minimo - Setting minimum

Consente di scegliere tre livelli di minimo lampada - Allows you to select three levels of minimum lamp.

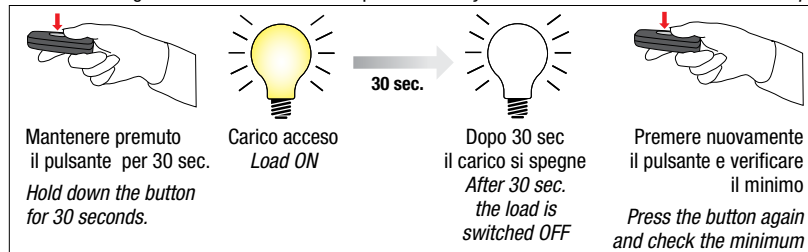

# VARIALUCE LED PASSANTE DA FILO - CORDSET LED DIMMER

Per lampade LED dimmerabili - For dimmable LED bulbs

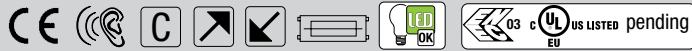

Comando a pulsante - Push-button control



**Cablaggio:** spina bipolare europea (2.5A 250V) e cavo piatto 2x0,75 mm<sup>2</sup> H03VVH2-F, o cavo tondo H03VV-F 2x075 mm.

**A richiesta per quantità** cablaggio di lunghezza diversa).

**Cordset with:** double pole Euro-plug (2.5A 250V) and flat cable 2x0,75 mm<sup>2</sup> H03VVH2-F or round cable H03VV-F 2x075 mm.

**On demand for quantity:** wiring of different lengths).

	W min. max.	V	Hz	LPH mm	☀	set. min	PCS	CCM cm <sup>3</sup>
LED	4÷260 *	220-240	50/60	60x110x28	NO	SI	20	6.800
	4÷260 *	110-127						

\* Max 10 lampadine LED - Max 10 LED lamps

**NEW 2026**



Cod: ACHIL661-260N

Cod.  
ACHIL661-260T

**ACHILLE 661-260 LED**  
Varialuce per lampade LED o alogene in classe II

- Comando a pulsante
- STOP al massimo, STOP al minimo
- Accensione graduale (antiabbagliamento)
- Spegnimento graduale
- Installazione passante sul cavo di alimentazione.
- Fusibile incorporato (T 800mA H 250V ~)
- Per lampade LED dimmerabili delle migliori marche in commercio.

**Trailing edge technolog**

**Electronic light dimmer class II for LED or halogen lamps**

- Push button control
  - STOP at maximum, STOP at minimum
  - Soft start (anti-glare)
  - Soft stop
  - Cable loop installation
  - Fuse incorporated (T 800mA H 250V ~)
  - For dimmable LED lamps from major producers
- Trailing edge technology**

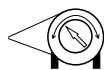

Trimmer per la regolazione del minimo  
Trimmer for setting the minimum

# VARIALUCE LED PASSANTE DA FILO - CORDSET LED DIMMER

Per lampade LED dimmerabili - For dimmable LED bulbs



Comando a pulsante - Push-button control



**Cablaggio:** spina bipolare europea (2.5A 250V) e cavo piatto 2x0,75 mm<sup>2</sup> H03VVH2-F, o cavo tondo H03VV-F 2x075 mm.

**A richiesta per quantità** cablaggio di lunghezza diversa).

**Cordset with:** double pole Euro-plug (2.5A 250V) and flat cable 2x0,75 mm<sup>2</sup> H03VVH2-F or round cable H03VV-F 2x075 mm.

**On demand for quantity:** wiring of different lengths).

	W min. max.	V	Hz	LPH mm	☀	set. min	PCS	CCM cm <sup>3</sup>
LED	4÷100 *	220-240	50/60	22x83x22	NO	SI	20	6.800
	4÷80 *	110-127						



DT/LED N  
Cod. RL0016/LAMPS



DT/LED T  
Cod. RL0039/LAMPS

**DT LED**

Varialuce per lampade LED o alogene in classe II

- Comando a pulsante
- STOP al massimo, STOP al minimo
- Accensione graduale (antiabbagliamento)
- Spegnimento graduale
- Installazione passante sul cavo di alimentazione.
- Fusibile incorporato (T 800mA H 250V ~)
- Per lampade LED dimmerabili delle migliori marche in commercio.

**Trailing edge technolog**

**Electronic light dimmer class II for LED or halogen lamps**

- Push button control
  - STOP at maximum, STOP at minimum
  - Soft start (anti-glare)
  - Soft stop
  - Cable loop installation
  - Fuse incorporated (T 800mA H 250V ~)
  - For dimmable LED lamps from major producers
- Trailing edge technology**

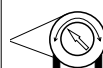

Trimmer per la regolazione del minimo  
Trimmer for setting the minimum

# VARIABLE LED PASSANTE DA FILO - CORDSET LED DIMMER

Per lampade LED dimmerabili - For dimmable LED bulbs



Design: Ezio Didone

**Comando a cursore - Slide control**

## 5000 LED

Comando a cursore. Variatore elettronico da pavimento in classe I e II, compatibile con lampadine LED dimmerabili delle migliori marche in commercio.

Slide control. Electronic floor class I and II dimmer combinabile with dimmable LED bulbs from major producers.

### Trailing edge technology

**Cablaggio:** spina bipolare europea (2.5A 250V) e cavo piatto 2x0,75 mm<sup>2</sup> H03VVH2-F, cavo tondo H03VV-F 2x075 mm, H03VV-F F 2x-3x0.75 mm.

**Cordset with:** double pole Euro-plug (2.5A 250V) and flat cable 2x0,75 mm<sup>2</sup> H03VVH2-F or round cable H03VV-F 2x075 mm, H03VV-F F 2x-3x0.75 mm.



	W <small>min. max.</small>	V	Hz	LPH <small>mm</small>			PCS	CCM <small>cm<sup>3</sup></small>
<b>LED</b>	<b>4÷100*</b>	100-240	50/60	45x150x29	●	SI	80	29.913
<b>HALO</b>	<b>40÷250</b>	220-240	50/60	45x150x29	●	SI	80	29.913
	<b>10÷150</b>	100-127						

\* Max 10 lampen LED - Max 10 LED lampe



**5000 LED N**  
Cod. RS7101/LED



**5000 LED T**  
Cod. RS7118/LED

**Comando a cursore - Slide control**

## RT81 LED

Comando a cursore. Variatore elettronico da pavimento in classe I e II, compatibile con lampadine LED dimmerabili delle migliori marche in commercio.

Slide control. Electronic floor class I and II dimmer combinabile with dimmable LED bulbs from major producers.

### Trailing edge technology

**Cablaggio:** spina bipolare europea (2.5A 250V) e cavo piatto 2x0,75 mm<sup>2</sup> H03VVH2-F o cavi tondi H03VV-F 2x075 mm, H03VV-F F 2x-3x0.75 mm.

**Cordset with:** double pole Euro-plug (2.5A 250V) and flat cable 2x0,75 mm<sup>2</sup> H03VVH2-F or round cables H03VV-F 2x075 mm, H03VV-F F 2x-3x0.75 mm.



	W <small>min. max.</small>	V	Hz	LPH <small>mm</small>			PCS	CCM <small>cm<sup>3</sup></small>
<b>LED</b>	<b>4÷100*</b>	100-240	50/60	71x115x39	●	SI	15	6.800
<b>HALO</b>	<b>40÷250</b>	220-240	50/60	71x115x39	●	SI	15	6.800
	<b>10÷150</b>	100-127						

\* Max 10 lampadine LED - Max 10 LED lamps

### Conformità CE direttiva - CE conformity standard

- 2014/35/EU

- 2014/30/EU

Certificata da DEKRA - DEKRA certificate



**RT81 LED N**  
Cod. RL1104/LED



**RT81 LED B**  
Cod. RL1112/LED

# VARIABLE LED PASSANTE DA FILO - CORDSET LED DIMMER

Per lampade LED dimmerabili - For dimmable LED bulbs



CE, C, Design: Zecca & Zecca, Comando rotativo - Rotary control

## 101 LED

Comando rotativo. Variatore elettronico da tavolo in classe II, compatibile con lampadine LED dimmerabili delle migliori marche in commercio.

Rotary control. Electronic table class II dimmer combinabile with dimmable LED bulbs from major producers.

### Trailing edge technology

101 LED è disponibile anche precablato (nero e trasparente).

**Cablaggio:** spina bipolare europea (2,5A 250V) e cavo piatto H03VVH2-F 2x0,75 mm<sup>2</sup> o cavo tondo H03VV-F 2x075 mm.

101 LED is also available pre-wired (black and transparent).

**Wiring:** European bi-pole plug (2.5A 250V) and 2x0.75 mm<sup>2</sup> H03VVH2-F flat cable or H03VV-F 2x075 mm. round cable.



	W min. max.	V	Hz	LPH mm	☀️	set. min.	PCS	CCM cm <sup>3</sup>
LED	4÷100 *	220-240	50/60	40x89x27	●	NO	20	6.800
	4÷80 *	100-127						
HALO	25÷160	220-240	50/60	40x89x27	●	NO	20	6.800
	25÷80	100-127						

\* Max 10 lampen LED - Max 10 LED lampe



101 LED N  
Cod. RL7200/LED



101 LED B  
Cod. RL7218/LED



101 LED P  
Cod. RL7226/LED



101 LED T  
Cod. RL7234/LED



## RTS1 LED

Comando rotativo. Variatore elettronico da tavolo in classe I e II, compatibile con lampadine LED dimmerabili delle migliori marche in commercio.

Rotary control. Electronic table class I and II dimmer combinabile with dimmable LED bulbs from major producers.

### Trailing edge technology

**Cablaggio:** spina bipolare europea (2.5A 250V) e cavo piatto 2x0,75 mm<sup>2</sup> H03VVH2-F o cavi tondi H03VV-F 2x075 mm, H03VV-F F 2x-3x0.75 mm.

**Cordset with:** double pole Euro-plug (2.5A 250V) and flat cable 2x0,75 mm<sup>2</sup> H03VVH2-F or round cables H03VV-F 2x075 mm, H03VV-F F 2x-3x0.75 mm.



## Comando rotativo - Rotary control

	W min. max.	V	Hz	LPH mm	☀️	set. min.	PCS	CCM cm <sup>3</sup>
LED	4÷100 *	100-240	50/60	45x150x29	●	SI	20	6.800
HALO	40÷250	220-240	50/60	45x150x29	●	SI	20	6.800
	10÷150	100-127						

\* Max 10 lampadine LED - Max 10 LED lamps



RTS1 LED N  
Cod. RL1618/LED



RTS1 LED T  
Cod. RL1621/LED

# VARIABLE LED PASSANTE DA FILO - CORDSET LED DIMMER

Per lampade LED dimmerabili - For dimmable LED bulbs

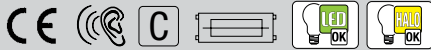

Comando a pulsante - Push button control

## CROSS LED

Comando a pulsante.

Varialuce elettronico da piede in classe II, compatibile con lampadine LED dimmerabili delle migliori marche in commercio.

Push button control.

Electronic class II dimmer for floor combinable with dimmable LED bulbs from major producers.

Trailing edge technology

	W min. max.	V	Hz	LPH mm			PCS	CCM m <sup>3</sup>
LED	4÷100 *	100-240	50/60	76x95x36	●	SI	12	6.800
HALO	25÷160	220-240	50/60	76x95x36	●	SI		
	25÷80	100-127						

\* Max 10 lampadine LED - Max 10 LED lamps

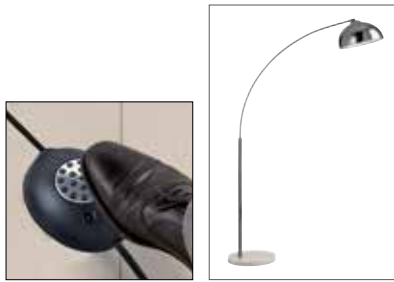

CROSS LED F-N  
Cod. RL0015/LAMPS



CROSS LED F-B  
Cod. RL0023/LAMPS



CROSS LED F-T  
Cod. RL0038/LAMPS



# VARIABLE TOUCH LED

Per lampade LED dimmerabili - For dimmable LED bulbs

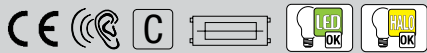

## Comando sensoriale continuo - Continuous touch control

### RT78SC LED

Comando sensoriale continuo. Variatore elettronico da tavolo o pavimento in classe I e II, compatibile con lampadine LED dimmerabili delle migliori marche in commercio.

Continuous sensorial control. Electronic table or floor class I and II dimmer combinable with dimmable LED bulbs from major producers.

### Trailing edge technology

### Tipo di cavi compatibili - Compatible cables

piatto / flat	H03VVH2 - F 2x0.75mm
tondo/ round	H03VV-F 2x075 mm
	H03VV-F F 2x-3x0.75 mm

	W min.-max.	V	Hz	LPH mm	Sun	set. min	PCS	CCM cm <sup>3</sup>
LED	4÷100 *	100-240	50/60	106x57x34	NO	SI	50	29.913
HALO	40÷250	220-240	50/60	106x57x34	NO	SI	50	29.913
	10÷150	100-127						

\* Max 10 lampadine LED - Max 10 LED lamps



RT78SC LED N  
Cod. RN0145/LED



RT78SC LED T  
Cod. RN0141/LED



RT78SC LED P  
Cod. RN0142/LED

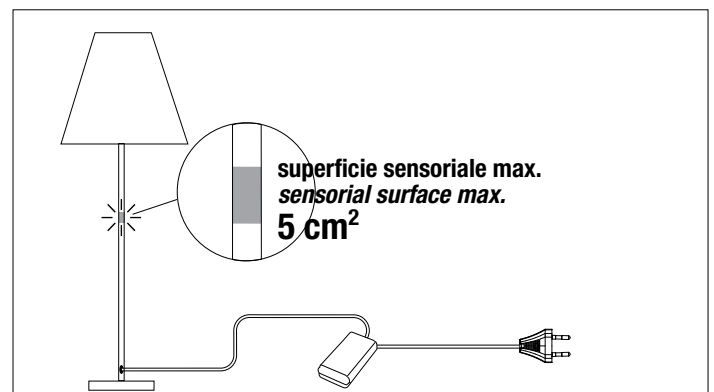

# VARIABLE TOUCH LED

Per lampade LED dimmerabili - For dimmable LED bulbs



## Comando sensoriale continuo - Continuous touch control

### RT52S LED

Comando sensoriale continuo. Varialuca elettronico da tavolo o pavimento in classe I e II, compatibile con lampadine LED dimmerabili delle migliori marche in commercio.

*Continuous sensorial control. Electronic table or floor class I and II dimmer combinable with dimmable LED bulbs from major producers.*

	W <small>min. max</small>	V	Hz	LPH <small>mm</small>			PCS	CCM cm <sup>3</sup>
LED	4÷100 *	220-240	50/60	45x27,5	NO	SI	40	2.760
	4÷80 *	100-127						
HALO	25÷160	220-240						
	25÷80	100-127						

\* Max 10 lampadine LED - Max 10 LED lamps

La regolazione avviene agendo sulla parte sensoriale predisposta sulla lampada. Accensione e spegnimento avvengono tramite un breve tocco sulla parte sensoriale, la regolazione mantenendo il contatto sino a raggiungere il livello di intensità desiderato. L'utilizzo con lampade a LED potrebbe rendere necessaria l'impostazione del minimo, in questo caso bisognerà mantenere un contatto prolungato sulla parte sensoriale >30 sec. fino allo spegnimento del carico, dopodiché interrompere il contatto e riaccendere con un breve tocco per verificare se il minimo impostato è idoneo altrimenti ripetere l'operazione. Sono disponibili 3 diversi livelli di minimo impostabili.

*Regulation occurs by acting on the touch lamp sensor part. The lamp can be switched on and off by briefly touching the sensor part; regulation can be performed by maintaining contact until the desired level of intensity is reached. Use with LED lamps could require minimum voltage regulation; in this case, maintain a prolonged contact on the touch sensor part (> 30 sec.) until the load shutdown, then break contact and switch on again with a brief touch to check whether the minimum voltage set is suitable, otherwise repeat the operation. 3 different levels of minimum voltage can be set.*

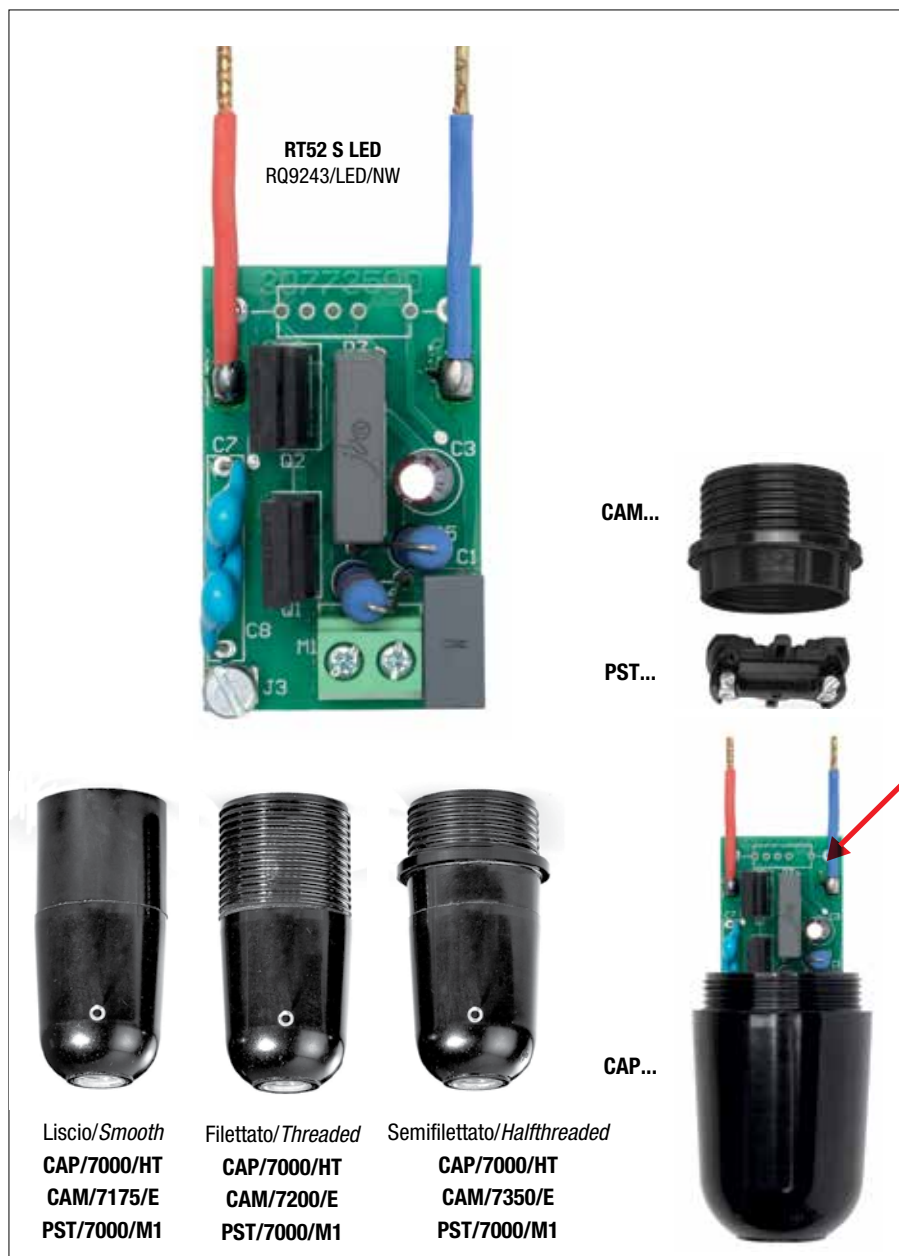

# VARIABLE UNIVERSALE - UNIVERSAL DIMMER

Per lampade LED dimmerabili - For dimmable LED bulbs



LT 2 UN NEW - Cod. RM0545



Regolatore da incasso universale con comando a pulsante separato.

È possibile controllare: lampade alogene, lampade ad incandescenza, trasformatori elettronici, LED Driver DIM, lampade LED dimmerabili (compatibili tecnologia **Trailing edge - IGBT**).

Universal Built-in rotary dimmer with separate push-button control.

It is possible to control: halogen lamps, incandescent lamps, electronic transformers, LED Driver DIM, dimmable LED bulbs (compatible to **Trailing edge technology - IGBT**).

### Selezione Dip-Switch - Dip-Switch selection

Funzionamento MASTER  
Operation MASTER



1 = OFF

Funzionamento SLAVE  
Operation SLAVE



1 = ON

Impostazione minimo al 10%  
The minimum setting to 10%



2 = OFF

Impostazione minimo al 20%  
The minimum setting to 20%



2 = ON

**Regolazione del minimo:** in caso di sfarfallio potrebbe essere necessaria la regolazione del minimo tramite dip switch.

**Idling adjustment:** the minimum setting by dip switch is required in case of flicker

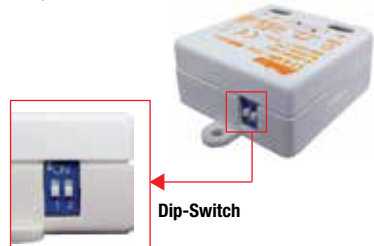

Dip-Switch

Articolo Article	Codice Code	V	Hz	LPH mm	☀️	set. min	PCS	CCM cm³
LT 2 UN	RM0545	220-240	50	42x40x23	NO	SI	10	1.734

LED	4±100*	max 10 lampadine LED/max 10 Lamps LED
HALO	4±250	
TRAFO TBT DIM	Trafo TBT DIM	max 100W
LED DRIVER DIM	LED Driver DIM pag. 46	max 100W

\* 10 lampadine max è il numero garantito e verificato da L.C. RELCO, non esiste uno standard costruttivo per le lampade a LED quindi il dispositivo potrebbe funzionare correttamente anche con un numero maggiore, 15÷20, previa verifica ufficio tecnico L.C. RELCO  
10 bulbs is the maximum quantity tested and granted by LC RELCO. Currently a proper standard for led bulbs is missing, so we just can come to the conclusion that the device could work even with more bulbs, like 15 to 20, but we recommend to proceed with this solution before LC RELCO has duly tested it in its laboratories

### Caratteristiche Generali

- Installazione in scatole di derivazione.
- Regolazione da più punti per mezzo di pulsanti normalmente aperti senza spia luminosa incorporata, di qualsiasi serie
- Assenza di ronzio acustico
- Protezione elettronica contro il sovraccarico e/o cortocircuito, auto ripristinabile
- Soft Start - Soft Stop
- Memoria di intensità luminosa (salvo interruzioni di rete superiori a 0,2 sec.)
- Potenza dissipata 2W/A
- Collegamento con morsetteria

**Comando sincronizzato:** dove fosse necessario gestire una potenza superiore sarà possibile realizzare un collegamento fino ad un massimo di 5 apparecchiature (Vedi Fig. 3) con comando sincronizzato; questo tipo di collegamento è possibile solo se tutti gli LT 2 UN sincronizzati sono alimentati sulla stessa fase. La selezione del tipo di funzionamento (Master/Slave) può essere effettuata tramite DIP 1. La selezione deve essere effettuata in assenza di tensione di rete.

**Impostazione del minimo:** Tramite il DIP 2 è possibile impostare il livello minimo di funzionamento ad un livello del 10% oppure del 20%. La selezione deve essere effettuata in assenza di tensione di rete.

### General Features

- Installation in junction boxes.
- Regulation from several points with any push button not fitted with warning lights
- No acoustic buzzing
- Electronic protection against overloads and/or short-circuits, with auto reset
- Soft Start - Soft Stop
- Brightness memory (except for mains power cuts above 0.2 sec.)
- 2W/A Dissipated power
- Connection to a pole terminal board

**Synchronised control:** where it is necessary to manage a higher power, you can connect up to 5 devices (See Fig. 3) with synchronised control; this type of connection is only available if all the synchronised LT 2 UN are supplied on the same phase. The operating mode (Master/Slave) can be selected using DIP 1. The selection must be made with no mains voltage.

**Minimum voltage regulation:** the minimum operational level can be set at a level of 10% or 20% using DIP 2. The selection must be made with no mains voltage.

Fig. 3 - Collegamento sincronizzato - Synchronized connection

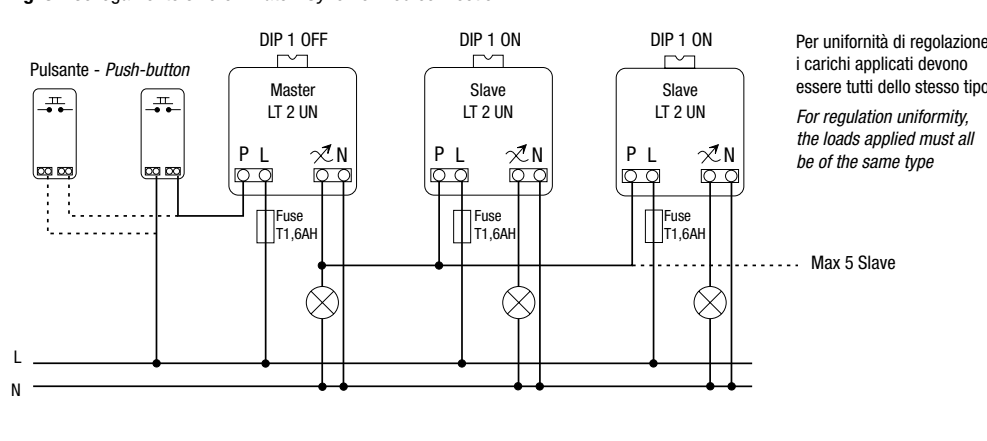

Fig. 1 - Schema di collegamento con trasformatore elettronico o LED Driver DIM  
Wiring diagram with electronic transformer or LED Driver DIM

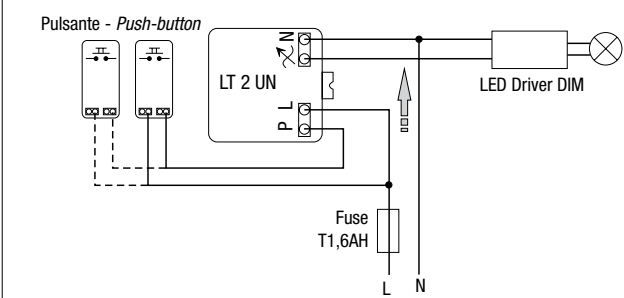
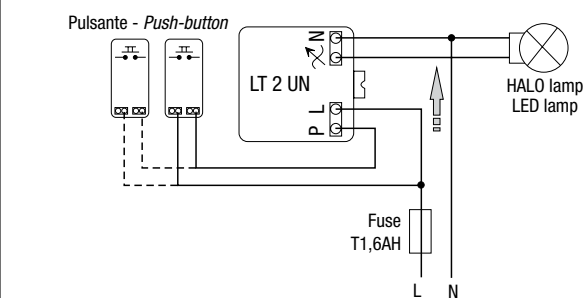

Fig. 2 - Schema di collegamento con lampade alogene, Led dimmerabili  
Wiring diagram with halogen, Led dimmable lamps



# REGOLATORI DA INCASSO 1-10V - 1-10V BUILT-IN DIMMER



Article	Code		VA				PCS	CCM cm <sup>3</sup>
DIM34SL	RM2360	International	250	6 max	35	●	20	2.760
DIM34LT	RM2365	Light	250	6 max	35	●	20	2.760
DIM34MA	RM2370	Magic	250	6 max	39	●	20	2.760
DIM34VI	RM2375	Vimar Idea	250	6 max	37	●	20	2.760
DIM34VP	RM2376	Vimar Plana	250	6 max	37	●	20	2.760

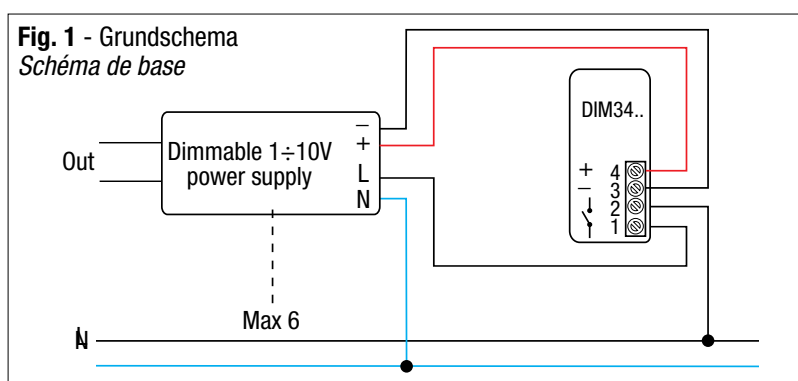

Interfaccia passiva da incasso per la regolazione di LED Driver e ballast elettronici dimmerabili con ingresso 1÷10Vdc.

*Built-in passive interface for dimmable LED driver and ballast with 1÷10Vdc input.*



**Il numero di reattori massimo è riferito al controllo 1÷10Vdc - The maximum number of ballasts is referred to control 1÷10Vdc**

## Caratteristiche generali

- Interfaccia passiva, per reattori elettronici dimmerabili con segnale 1÷10Vcc
- Portata massima 6 reattori
- Portata massima del contatto di chiusura (push-push) 250VA (1A)

## Funzionamento

DIM34.. permette la regolazione di reattori elettronici e LED Driver dimmerabili con ingresso 1÷10Vcc. La regolazione è di tipo rotativo ed avviene mediante rotazione della manopola, accensione e spegnimento a pressione direttamente sulla manopola. Consente il controllo simultaneo di 6 reattori (Fig. 1), la lunghezza massima dei conduttori non dovrà essere superiore a 30 metri. La potenza massima applicabile al contatto di spegnimento, morsetti 1 - 2, è pari a 250VA (1A)

## Caratteristiche generali

- Built-in passive interface, for dimmable electronic ballast with 1÷10Vcc signal.
- Maximum capacity 6 ballasts
- Maximum capacity of the closure contact (push-push) 250VA (1A)

## Working

DIM34.. allows dimming of dimmerable electronic ballast and LED Driver with 1÷10Vcc input. The regulation is rotary and takes place by turning the handle, turning on and off is through pressure applied directly into the handle. Allows the simultaneous control of 6 ballasts (Fig. 1), the maximum length of the conductors must not exceed 30 meters. The maximum power which can be applied to the turn off contact, terminals 1 - 2, is equal to 250VA (1A).

# REGOLATORI DA INCASSO LED per lampade LED dimmerabili

## BUILT-IN LED DIMMER for dimmable LED bulbs



Articolo		Codice	V	Hz	Mod			PCS		CCM cm <sup>2</sup>
DIMUNICOLED 34 DSL	International	RP0953/UNICO	230	50	1	●	SI	5		1.120
DIMUNICOLED 34 DLT	Light	RP0956/UNICO	230	50	1	●	SI	5		1.120
DIMUNICOLED 34 DVP	Vimar Plana	RP0962/UNICO	230	50	1	●	SI	5		1.120
DIMUNICOLED 34 DMA	Magic	RM0659/UNICO	230	50	1	●	SI	5		1.120
DIMUNICOLED 34 DVI	Vimar Idea	RM0675/UNICO	230	50	1	●	SI	5		1.120
DIMUNICOLED 34 DLI	Living	RM2317/UNICO	230	50	1	●	SI	5		1.120
DIMUNICOLED 34 DV8	Vimar 8000	RM0691/UNICO	230	50	1	●	SI	5		1.120
DIMUNICOLED 34 DAN	Arkè Nera	RM0692/UNICO	230	50	1	●	SI	5		1.120
DIMUNICOLED 34 DAB	Arkè Bianca	RM0693/UNICO	230	50	1	●	SI	5		1.120
DIMUNICOLED 34 DMX	Matix	RM0660/UNICO	230	50	1	●	SI	5		1.120

	<b>LED</b>	<b>4÷160 *</b> max 10 lampadine LED
	<b>HALO</b>	<b>10÷160</b>

\* 10 lampadine max è il numero garantito e verificato da RELCO, non esiste uno standard costruttivo per le lampade a LED quindi il dispositivo potrebbe funzionare correttamente anche con un numero maggiore, 15÷20, previa verifica ufficio tecnico RELCO  
 \* 10 bulbs max is the number guaranteed and verified by RELCO, there is no construction standard for LED lamps so the device could work correctly even with a higher number, 15 ÷ 20, after checking RELCO technical office

Dimmer rotativo da incasso adatto alla regolazione di: lampadine a LED dimmerabili delle migliori marche in commercio (la potenza applicabile è pari ad un minimo di 4W ad un massimo di 160W) e classiche lampade alogene (potenza da 10W a 160W). Il comando di accensione e spegnimento avviene mediante pressione sulla manopola, la regolazione mediante la rotazione della manopola stessa. Dimmer di ultima generazione che sfrutta le più recenti tecnologie del microprocessore.

### Regolazione lampade LED dimmerabili

Non essendo ancora in vigore uno standard costruttivo relativo alle lampade LED, i produttori scelgono autonomamente il tipo tecnologia costruttiva, purtroppo questo ha, fino ad oggi, creato disagio nella scelta del dimmer adeguato, sia per tecnologia di regolazione (TRIAC o IGBT), che per tipo di collegamento, dove in alcuni casi si rende necessario anche il collegamento del neutro sul dimmer.

### Dimmer unico

Questo nuovo modello, oltre a disporre della possibilità di selezione del tipo di funzionamento tramite dip-switch, IGBT (Trailing edge) oppure TRIAC (Leading edge), offre anche la possibilità di effettuare il collegamento con o senza neutro, tutto con il medesimo prodotto.

*Recessed rotary dimmer suitable for the regulation of: dimmable LED bulbs of the best brands on the market (the applicable power is equal to a minimum of 4W to a maximum of 160W) and classic halogen lamps (power from 10W to 160W). The on and off control is done by pressing the knob, the adjustment by turning the knob itself. Latest generation dimmer that takes advantage of the latest microprocessor technologies.*

### Adjustment of dimmable LED lamps

*As a construction standard relating to LED lamps is not yet in force, manufacturers independently choose the type of construction technology, unfortunately this has, up to now, created inconvenience in choosing the appropriate dimmer, both for regulation technology (TRIAC or IGBT), which by type of connection, where in some cases it is also necessary to connect the neutral on the dimmer.*

### Unique dimmer

This new model, in addition to having the possibility of selecting the type of operation via dip-switch, IGBT (Trailing edge) or TRIAC (Leading edge), also offers the possibility of connecting with or without neutral, all with the same product.



International



Light



Vimar Plana



Magic



Vimar Idea



Living



Vimar 8000



Arkè Nera



Arkè Bianca



Matix

# REGOLATORI DA INCASSO LED per lampade LED dimmerabili

## BUILT-IN LED DIMMER for dimmable LED bulbs



### Schema di collegamento CON NEUTRO - Connection diagram WITH NEUTRAL

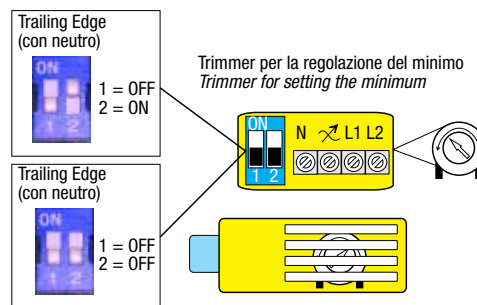
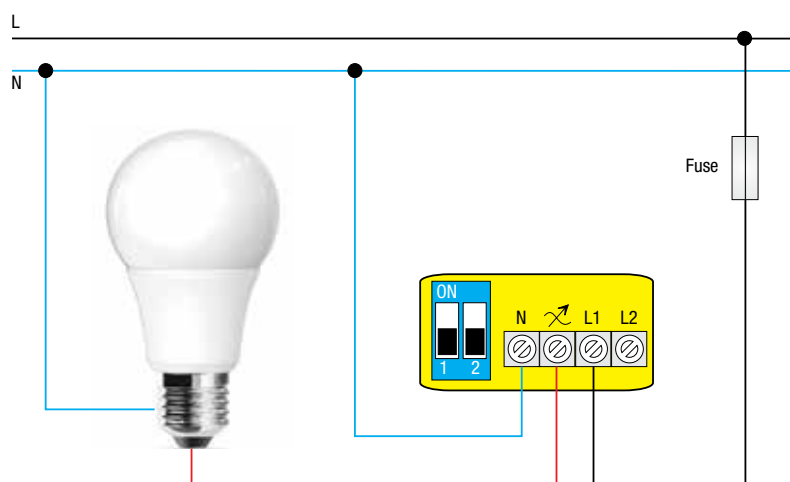

La regolazione del minimo è necessaria nel caso si presentasse sfarfallio. La regolazione dovrà essere fatta con il potenziometro posizionato al minimo

*The minimum adjustment is necessary in the event of a flicker. Adjustment must be made with the potentiometer positioned to a minimum*

### Schema di collegamento SENZA NEUTRO - Connection diagram WITHOUT NEUTRAL

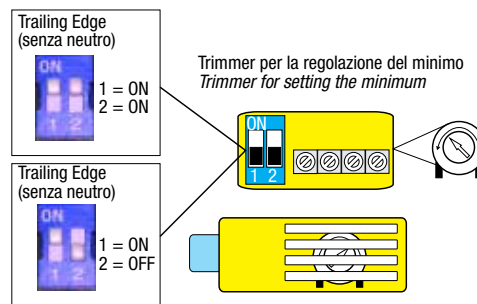
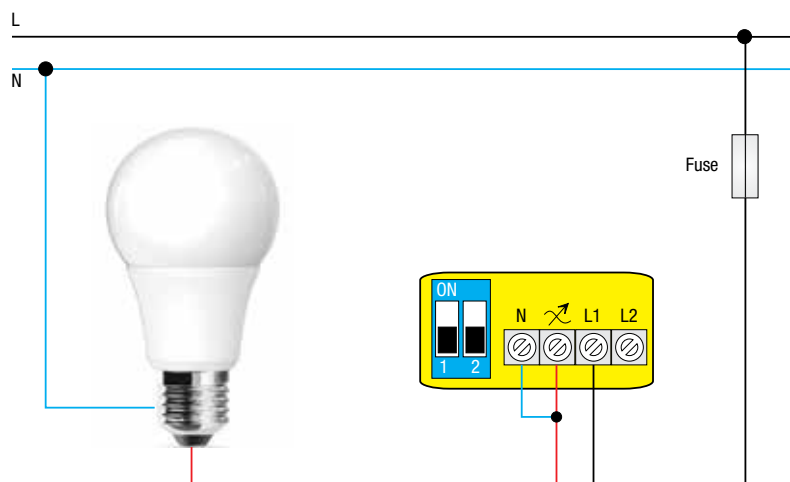

La regolazione del minimo è necessaria nel caso si presentasse sfarfallio. La regolazione dovrà essere fatta con il potenziometro posizionato al minimo

*The minimum adjustment is necessary in the event of a flicker. Adjustment must be made with the potentiometer positioned to a minimum*

### Dimmerazione a taglio di fase con mosfet

La dimmerazione a taglio di fase con MOSFET può essere fatta sia in Leading Edge che in Trailing Edge ed è controllata da un microprocessore che gestisce contemporaneamente i due semiconduttori Mosfet e che ne aggiusta in modo puntuale qualsiasi problema di perdita di sincronia con le semionde, riducendo a zero il problema dello "sfarfallio" delle lampade a LED. È indicata per la dimmerazione di tutti i tipi di carico ad eccezione dei motori per ventilatori.

### Phase cut dimming with mosfet





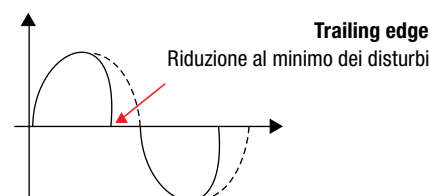
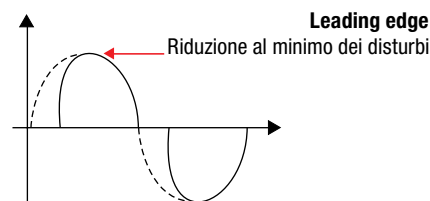



Phase cut dimming with MOSFET can be done both in Leading Edge and Trailing Edge and is controlled by a microprocessor that manages the two Mosfet semiconductors at the same time and that punctually adjusts any problem of loss of synchrony with the half waves, reducing to zero the problem of the "flicker" of the LED lamps.

It is suitable for dimming all types of loads with the exception of fan motors.



# REGOLATORI PER VENTILATORI - *BUILT-IN DIMMER FOR FANS*

CE L  **Leading edge technology**

Article	Code								PCS 	CCM cm <sup>3</sup>
<b>RM34DMA</b>	RN0567	Magic	40÷160	220-240	50/60	1	39	●	20	2.760
<b>RM34DLI</b>	RN0575	Living	40÷160	220-240	50/60	1	40	●	20	2.760
<b>RM34DSL</b>	RN0914	International	40÷160	220-240	50/60	1	35	●	20	2.760
<b>RM34DLT</b>	RN0906	Light	40÷160	220-240	50/60	1	35	●	20	2.760
<b>RM34DVI</b>	RN0583	Vimar Idea	40÷160	220-240	50/60	1	37	●	20	2.760
<b>RM34DVP</b>	RN0585	Vimar Plana	40÷160	220-240	50/60	1	37	●	20	2.760
<b>RM34DV8</b>	RN0534	Vimar 8000	40÷160	220-240	50/60	1	37	●	20	2.760



Variatore da incasso con comando a deviatore adatto per la regolazione di ventilatori.  
Non adatto alla regolazione di ventilatori con cambio di velocità a cordicella e/o fan coil.

*Built-in two-way control dimmer only for fans.*

*Not suitable for regulation of fans a speed shift cord and/or fan coil*

# Varialuce per moduli LED *Acrich* o Ready line smd Dimmer for LED modules *Acrich* or Ready line smd



Codice Code	Colore Color	W min. max.	V	Hz		PCS
RL7180	N	4÷100 (max 5 Acrich mod.)	220-240	50		20
RL7190	T	4÷100 (max 5 Acrich mod.)	220-240	50		20

Dimensioni (mm) - Dimensions (mm)

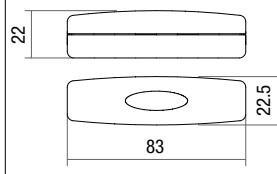

Varialuce elettronico con comando a pulsante per moduli LED 230V

Electronic dimmer with button control for LED modules 230V

Codice Code	Colore Color	W min. max.	V	Hz		PCS
RL7181	N	4÷100 (max 5 Acrich mod.)	220-240	50		10
RL7191	T	4÷100 (max 5 Acrich mod.)	220-240	50		10

Dimensioni (mm) - Dimensions (mm)

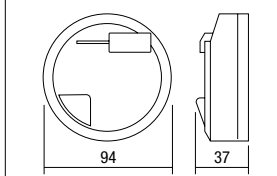

Varialuce elettronico con comando a pulsante per moduli LED 230V

Electronic dimmer with button control for LED modules 230V



SNELLO / ACR N  
RL7180



On demand



On demand



SNELLO / ACR T  
RL7190



RONDÓ / ACR N  
RL7181



On demand



On demand



RONDÓ / ACR T  
RL7191

# Varialuce per moduli LED *Acrich* o Ready line smd Dimmer for LED modules *Acrich* or Ready line smd



DIMLED 34 D...



International



Light



Vimar Plana

Art.	Code	Serie	W <small>min. max.</small>	V	Hz	Mod	PCS	CCM <small>cm<sup>3</sup></small>
DIMLED 34 DSL	RP0953	International	4÷100	230	50	1	10	6.800
DIMLED 34 DVP	RP0962	Vimar Plana	*	230	50	1	10	6.800
DIMLED 34 DLT	RP0956	Light		230	50	1	10	6.800

\* Max 5 moduli Acrich - Max 5 Acrich modules  
Varialuce rotativo da incasso per moduli LED 230V  
Built-in rotary dimmer for LED modules 230V.



**UNIVERSAL**

LT 1 UN - Cod. RM0540



Dimensioni (mm) - Dimensions (mm)

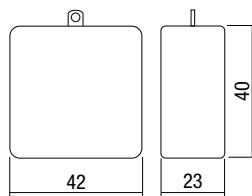

W <small>min. max.</small>	V	Hz	PCS	CCM <small>cm<sup>3</sup></small>
4÷250 - Halo				
4÷100W (max n° 5 Acrich modules)	220-240	50	10	1.734
4÷100W (max n° 5 LED DIM lamps)				

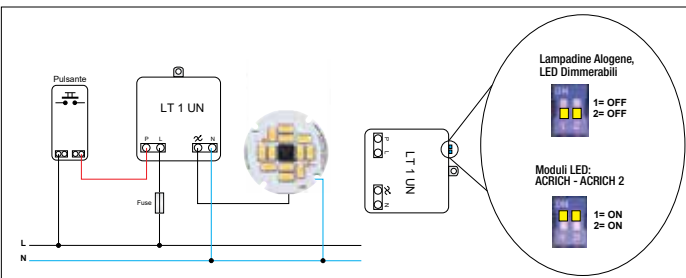

Varialuce da incasso universale con comando a pulsante separato, compatibile con lampadine alogene e LED dimmerabili delle migliori marche in commercio e moduli LED Acrich2, LED Acrich3 e LED Driver dimmerabili.

Universal Built-in rotary dimmer combinable with dimmable halogen LED bulbs from major producers, and LED Acrich2, LED Acrich3 modules, dimmable LED Driver

**C** Trailing edge technology (IGBT)



# RELÉ UNIVERSALE SILENZIOSO - *UNIVERSAL SILENT RELAY*

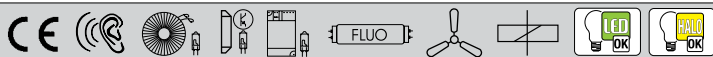

RL UN - Cod. RM0535/NEW

**ON/OFF only**

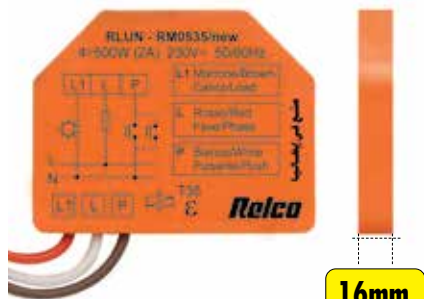

**16mm**

W (min.-max.)	V	Hz	VA	LPH (mm)	PCS	CCM cm <sup>3</sup>
4÷500	220-240	50/60	4÷500	50x40x16	10	1.734

## Caratteristiche generali

- Relè passo-passo elettronico universale con comando a pulsante esterno (non fornito).
- Installazione in copriforo, scatole di derivazione, specchiere ecc.
- Comando da più punti per mezzo di pulsanti normalmente aperti di qualsiasi serie senza spia di segnalazione.
- Massima silenziosità di commutazione.
- Memoria di funzionamento anche in assenza di tensione di rete.
- Potenza applicabile vedi Tabella 1.
- Memoria di funzionamento anche in caso di assenza di tensione di rete.

L'alloggiamento non deve essere sottoposto all'azione diretta di fonti di calore. La temperatura ambiente di riferimento è di 35°C, ogni 5° in più ridurre del 20% la potenza di targa. L'installazione è da eseguirsi rispettando le norme CEI vigenti, dopo aver tolto tensione all'impianto, seguendo scrupolosamente gli schemi di collegamento, utilizzare del cavo di sezione adeguata (non inferiore a 1,5mm).

Ogni apparecchio è stato collaudato. Il funzionamento è garantito a condizione che siano rispettate le norme d'installazione sopra

## General characteristics

- Step electronic universal relay with external push button (not supplied).
- Controlled from several points with push buttons of any series without pilot light.
- Noiseless commutation.
- Memory function even when current is cut off
- It is controlled through buttons NO, with shutdown reference on NEUTRAL;
- Power handling see Tabel 1.
- Operation memory also without network voltage.

Keep housing away from direct sources of heat. The temperature should be 35°C, for every 5°C extra reduce power by 20%. Install respecting CEI after having switched off mains, and following carefully connection diagrams. Use cable of adequate size (not less than 1,5mm)

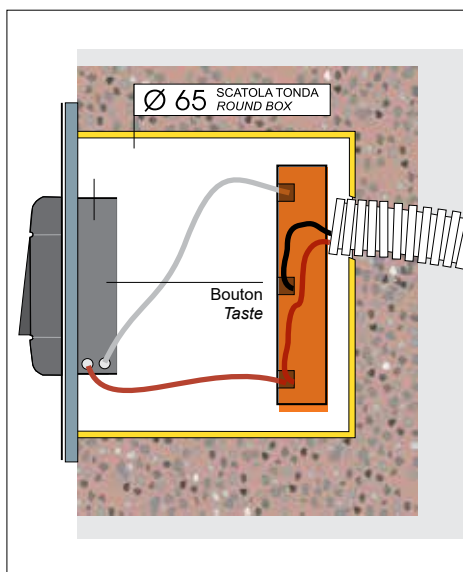

Schema di collegamento - *Wiring diagram*

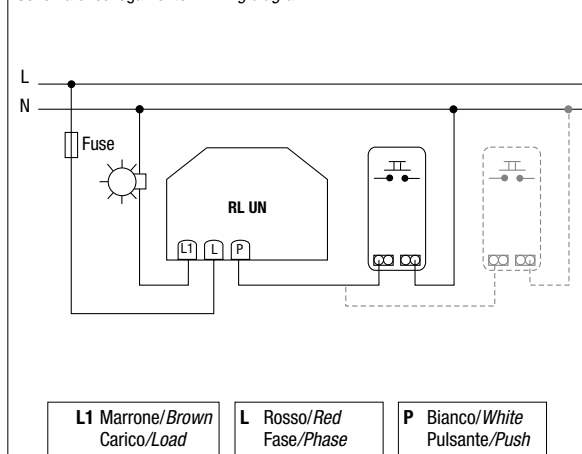

**L1** Marrone/Brown  
Carico/Load

**L** Rosso/Red  
Fase/Phase

**P** Bianco/White  
Pulsante/Push

**Tabella 1 - Table 1**  
**Carichi applicabili - Loads handling**

Carico Load	Potenza Power
HALO lamp	4÷500W
FLUO lamp	4÷250W
Trasformatori toroidali <i>Toroidal transformers</i>	4÷500W
Trasformatori elettronici <i>Electronic transformers</i>	4÷500W
Trasformatori lamellari <i>Electromechanical transformers</i>	4÷350W
Ventilatori <i>Fans</i>	4÷200W
LED lamp	4÷200W
Moduli Acrich <i>Acrich modules</i>	4÷200W

Montagebeispiel  
*Exemple d'assemblage*

# RILEVATORI DI PRESENZA INFRAROSSI CON CREPUSCOLARE OCCUPANCY DETECTOR WITH LIGHT SENSOR

Con/With  
Relè

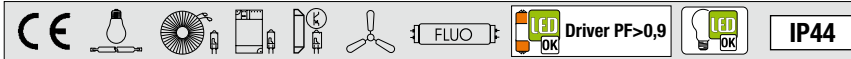

Code	W	VA	V	Hz	ta °C	PCS	CCM cm³
RM0295	500 *	200 *	220-240	50/60	-20...40	1	676

\* Per potenze superiori utilizzare un relè di appoggio - For higher powers use a external relay

Il rilevatore di PRESENZA ad infrarossi passivi con crepuscolare per impostazione soglia Lux ambiente di intervento, "percepisce" le variazioni di temperatura provocate dal movimento di persone o animali di grossa taglia entro la zona di copertura, accendendo automaticamente la luce. Lo spegnimento si avrà, dopo l'arresto del movimento, in base al tempo precedentemente impostato. Grazie alle sue particolari lenti, il rilevatore, è in grado di **percepire non solo il movimento ma anche la PRESENZA** di uno o più individui all'interno dell'ambiente controllato.

**Collegamento:** morsetti a vite (Fig. 1)

**Regolazione:** trimmer A e B (Fig. 2)

**Tempo di spegnimento:** 10" ÷ 7" (trimmer A)

**Sensibilità lux:** <10 Lux÷2000 Lux (trimmer B)

**Orientabilità sensore:** 60° orizzontale - 45° verticale (Fig. 3)

**Angolo rilevamento:** ambito visivo ellittico 180°, 12m in avanti (Fig. 4 - 5)

**Tipo di contatto:** relè interno

**Connessione:** 3 - 4 fili

**Absorbimento a riposo:** ~1W

The passive infrared PRESENCE detector with crepuscular perceives variations in temperature caused by the movement of people or big animals within the covered area, which automatically turns on the light. Shutdown will take place shortly after the motion within the range of detection stops, according to the previously set time.

Class II motion detector, fitted with variable threshold dusk activation to set the Lux intervention setting. Thanks to its particular lenses, the detector is able to **perceive not only the movement but also the PRESENCE** of one or more individuals within the controlled environment.

**Connection:** Screw clamps (Fig. 1)

**Setting:** trimmer A and B (Fig. 2)

**Switch-off time:** 10" ÷ 7" (trimmer A)

**Lux sensitivity:** <10 Lux÷2000 Lux (trimmer B)

**Sensor adjustability:** 60° horizontal axis - 45° vertical axis (Fig. 3)

**Detection angle:** 180° elliptical visual field, 12m forward (Fig. 4 - 5)

**Type of contact:** internal relay

**Connection:** 3 - 4 wires

**Stand-by absorption:** ~1W

## Installazione a parete

## Wall installation

Rilevatore di PRESENZA infrarossi  
Infrared PRESENCE detector



Dimensioni (mm) - Dimensions (mm)

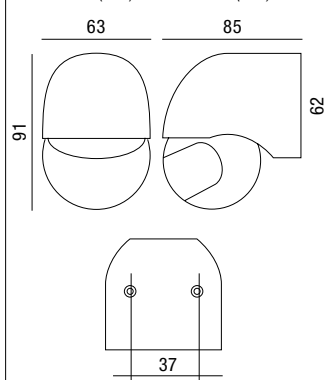

Fig. 1

Morsetti - Terminal block

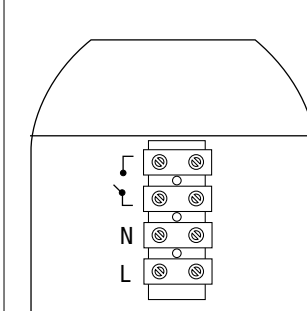
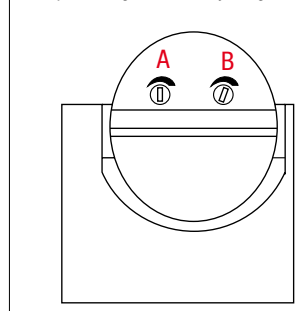

Fig. 2

Manopole di regolazione - Adjusting knobs



A = Time B = Lux



Fig. 3

Orientabilità sensore - Sensor adjustability

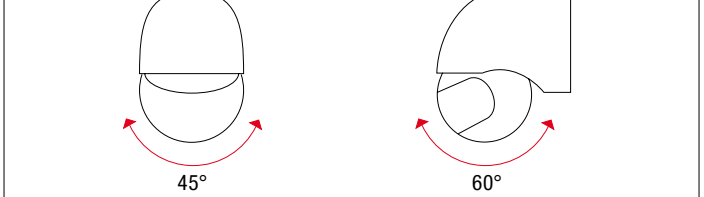

Fig. 4

Vista superiore - Top view

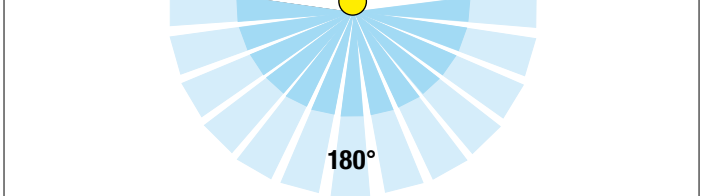
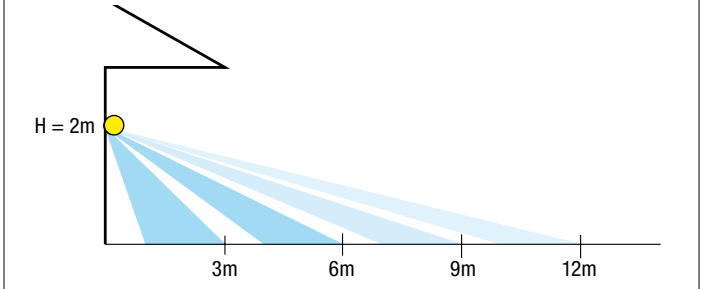

Fig. 5

Vista laterale - Side view



### Sensore di movimento luminosità - Movement/brightness sensor

A = Time



Impostazione del tempo di spegnimento dopo l'ultimo rilevamento  
Time setting to switch off after last detection.

B = Lux



Regola il livello del sensore, ossia la luminosità esterna a cui il sensore esterno si attiva, impostato su il sensore è sempre attivo nelle 24 ore  
It adjusts the sensor level, e.g. the external light that activates the external sensor, set on the sensor is always active, 24/24.

# RILEVATORI DI PRESENZA INFRAROSSI CON CREPUSCOLARE

## OCCUPANCY DETECTOR WITH LIGHT SENSOR

Con/With  
Relè

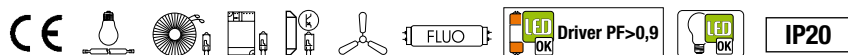

Code	W	VA	V	Hz	ta °C	PCS	CCM cm <sup>2</sup>
SM-0500	500 *	200 *	220-240	50/60	-20...40	1	640,00

\* Per potenze superiori utilizzare un relè di appoggio - For higher powers use a external relay

Rilevatore di PRESENZA ad infrarossi passivi con crepuscolare per impostazione soglia Lux ambiente di intervento per installazione a soffitto.

Il sensore "percepisce" le variazioni di temperatura provocate dal movimento di persone o animali di grossa taglia entro la zona di copertura, accendendo automaticamente la luce in base anche al livello di LUX ambiente precedentemente impostato.

Lo spegnimento si avrà, dopo l'arresto del movimento, in base al tempo precedentemente impostato. Grazie alle sue particolari lenti, il rilevatore, è in grado di **percepire non solo il movimento ma anche la PRESENZA** di uno o più individui all'interno dell'ambiente controllato.

Angolo di rivelamento: 360°

Altezza di montaggio: 2÷5 metri

Tempo di spegnimento: 10" ÷ 7' (trimmer A)

Ampiezza rilevamento: Ø 10m x H 2,5m

Sensibilità lux: <10 Lux÷2000 Lux (trimmer B)

Connessione: 3 fili

Assorbimento stand by: <0,5W

Passive infrared PRESENCE detector with crepuscular for a ceiling installation with brightness sensor for the LUX threshold setting within the range of intervention.

The sensor "perceives" variations in temperature caused by the movement of people or big animals within the covered area, which automatically turns on the light, which is also based on the previously set level of environmental LUX.

Shutdown will take place shortly after the motion within the range of detection stops, according to the previously set time.

Thanks to its particular lenses, the detector is able to **perceive not only the movement but also the PRESENCE** of one or more individuals within the controlled environment.

Detection angle: 360°

Assembly height: 2÷5 metres

Switch-off time: 10" ÷ 7' (trimmer A)

Detection Width: Ø 10m x H 2,5m

Lux sensitivity: <10 Lux÷2000 Lux (trimmer B)

Connection: 3 wires

Stand-by absorption: <0,5W

### Installazione ad incasso

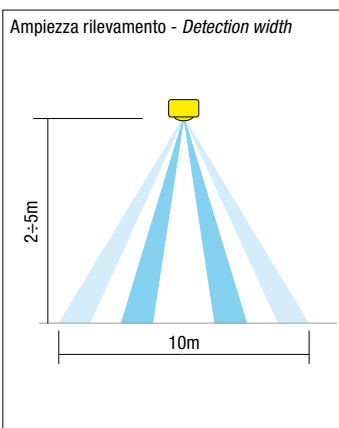

Dimensioni (mm) - Dimensions (mm)

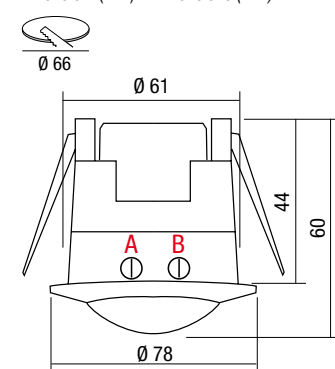

Schema di collegamento - Wiring diagram

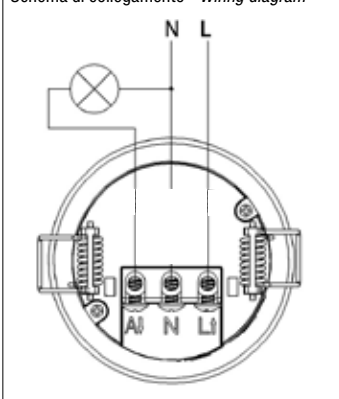

### Recessed installation

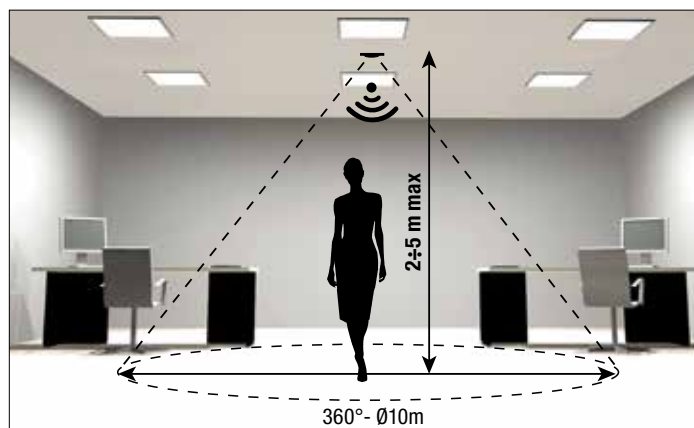

### Sensore di movimento luminosità - Movement/brightness sensor

<b>A = Time</b>	Impostazione del tempo di spegnimento dopo l'ultimo rilevamento Time setting to switch off after last detection.
<b>B = Lux</b>	Regola il livello del sensore, ossia la luminosità esterna a cui il sensore esterno si attiva, impostato su  il sensore è sempre attivo nelle 24 ore - It adjusts the sensor level, e.g. the external light that activates the external sensor, set on  the sensor is always active, 24/24.



cod. HBT DAP

Accessorio per montaggio a plafone  
Ceiling mount accessory

# SENSORI DI MOVIMENTO MICROONDE CON CREPUSCOLARE

## MICROWAVE MOTION DETECTOR WITH LIGHT SENSOR

Con/ With  
Relè



Code	W	VA	V	Hz	ta °C
ES-M08A	1000 *	500 *	220÷240	50/60	-30...70

\* Per potenze superiori utilizzare un relè di appoggio - For higher powers use a external relay

**Rilevatore di movimento a microonde con crepuscolare** per impostazione soglia minima Lux ambiente di intervento e con livello di stand-by impostabile (10-20-30%) con driver dimmerabili 0-10V; questa tecnologia emette onde elettromagnetiche ad alta frequenza (5,8GHz) e riceve il loro eco, in questo modo è in grado di riconoscere una qualsiasi variazione data da un oggetto non rilevato nella precedente analisi e verrà dato il comando di ON. La trasmissione ad alta frequenza è <10mW e risulta essere 100 volte inferiore alle emissioni di un comune telefono cellulare o di un forno a microonde che emettono mediamente 1000mW.

**Microwave motion detector with twilight** with adjustable stand-by level for setting Lux threshold for the intervention environment and with settable stand-by level (10-20-30%) with dimmable 0-10V driver; this technology it emits electromagnetic waves at a high frequency (5.8GHz) and receives their echoes. In this way, it can recognise any variation given by an object not detected in the previous analysis and the ON command will be given. High frequency transmission is <10mW and is 100 times lower than the emissions of a common mobile phone or a microwave oven emitting an average of 1000mW.



Dimensioni (mm) - Dimensions (mm)

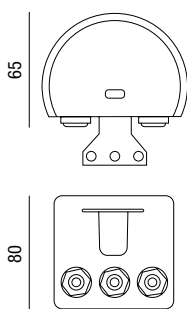

Schema collegamento - Wiring diagram

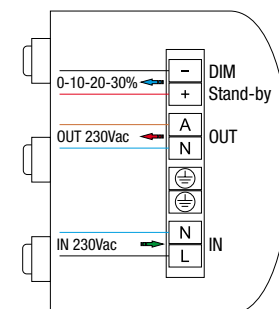

Esempio applicativo  
Installazione su corpo illuminante  
Application example  
Installation on lighting body

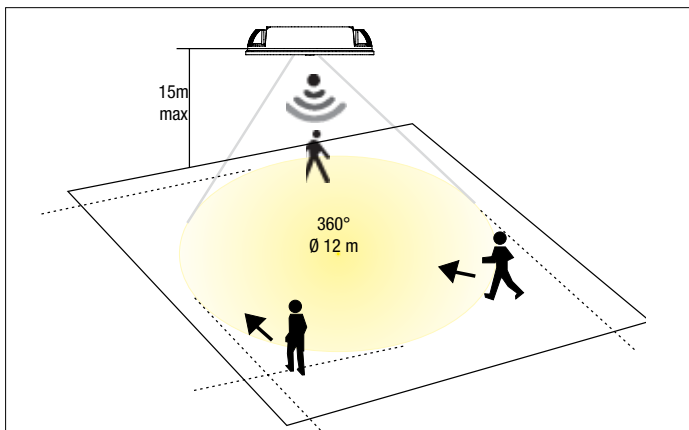

### Specifiche tecniche - Technical specification

Tensione di rete - Power supply	220-240Vac - 50/60Hz
Potenza - Power	1000W - 500VA
Frequenza - Frequency	5,8GHz
Angolo di rilevamento - Detection angle	360°
Velocità di rilevamento movimento - Motion detection speed	0,5-3m/s
Altezza di installazione - Assembly height	1÷15 m
Consumo energetico - Energy consumption	< 0,9W
Grado IP - IP degree	IP65
Tecnologia - Technology	Microonde - Microwave
Temperatura di funzionamento sensore - Sensor operating temperature	-35...50°C
Tempo di spegnimento - Switch-off time	10 sec + 30 min
Sensibilità lux - Lux sensitivity	5÷200 lux 24h
Sensibilità - Sensitivity	12m (regolabile - (reglable))
Trasmissione di segnale - Signal transmission	< 10mW
Stand-by dimming level	0%, 10%, 20%, 30%

### Trasmettitore incluso - Included transmitter

Carico acceso Load on

Carico spento Load off

Lampeggio di test del carico Lamp will be auto test to be on and off

Funzionamento automatico impostazione di fabbrica = 24h tempo 10'' - distanza 100% Automatic operation factory setting = 24h time 10'' - distance 100%

Ampiezza di rilevamento Detection width

Tempo di spegnimento Hold time

Sensibilità Lux Lux sensibility

Livello di luminosità in stand-by Stand-by dimming level  
OFF = 0%  
M1 = 10%  
M2 = 20%  
M3 = 30%

# RILEVATORI DI PRESENZA INFRAROSSI CON CREPUSCOLARE

## OCCUPANCY DETECTOR WITH LIGHT SENSOR

Con/ With  
Relè

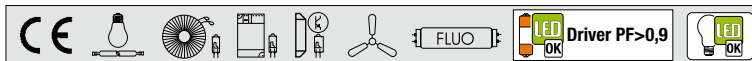

Code	W	VA	V	Hz	ta °C
ES-P18B	100 *	100 *	110-240	50/60	-20...40

\* Per potenze superiori utilizzare un relè di appoggio - For higher powers use a external relay

**Rilevatore di PRESENZA ad infrarossi passivi di dimensioni ridotte con crepuscolare** per impostazione soglia Lux ambiente di intervento. Installazione da incorporare con lente esterna IP65.

Il sensore, "percepisce" le variazioni di temperatura provocate dal movimento di persone o animali di grossa taglia entro la zona di copertura, accendendo automaticamente la luce, se necessario, in base al livello di Lux ambiente precedentemente impostato.

**Installazione: da incorporare**

**Angolo di rivelamento:** 120° / 360°

**Altezza di montaggio:** 4 metri max

**Tempo di spegnimento:** 10" ÷ 7'

**Ampiezza rilevamento:** 6 metri max

**Sensibilità lux:** <10 Lux÷2000 Lux

**Connessione:** con fili

**Assorbimento stand by:** < 0,5

**Passive infrared PRESENCE detector with reduced dimensions and twilight setting** for Lux threshold for the intervention environment, installation to be incorporated with IP65 external lens.

The sensor "perceives" the temperature variations caused by the movement of large people or animals within the coverage area, automatically turning on the light based on the previously set Lux environment level.

**Installation: built-in use**

**Detection angle:** 120° / 360°

**Assembly height:** 4 metres max

**Switch-off time:** 10" ÷ 7'

**Detection Width:** 6 metres max

**Lux sensitivity:** <10 Lux÷2000 Lux

**Connection:** with wires

**Stand-by absorption:** < 0,5

### Rilevatore di PRESENZA infrarossi

#### Infrared PRESENCE detector



#### Dimensioni (mm) - Dimensions (mm)

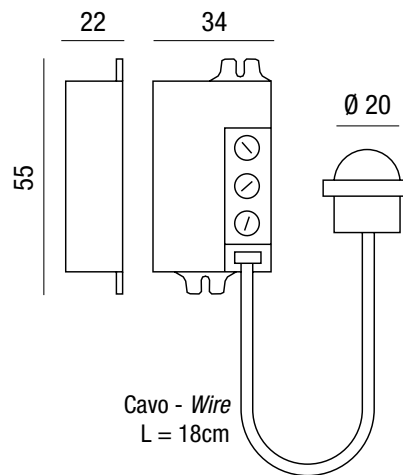

#### Schema collegamento - Wiring diagram

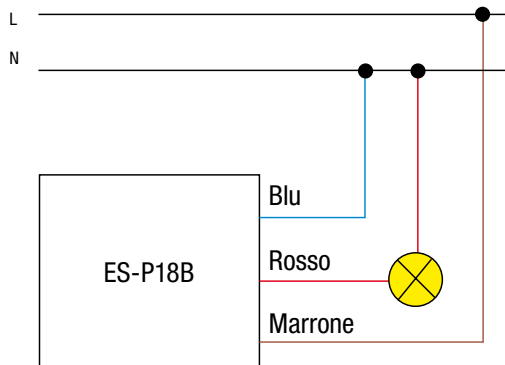

#### Ampiezza rilevamento - Detection width

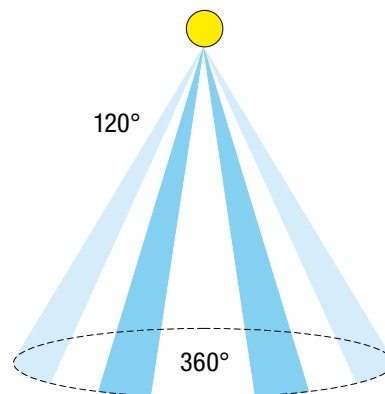

# SENSORI DI MOVIMENTO MICROONDE CON CREPUSCOLARE

## MICROWAVE MOTION DETECTOR WITH LIGHT SENSOR

Con/With  
Relè



Code	W	VA	V	Hz	ta °C	PCS	CCM cm²
BC360A-D02	1200 *	600 *	220-240	50/60	-20...50	1	336,30

\* Per potenze superiori utilizzare un relè di appoggio - For higher powers use a external relay

**Rilevatore di MOVIMENTO a microonde con crepuscolare** per impostazione soglia Lux ambiente di intervento, questa tecnologia consente di "nascondere" il rilevatore anche all'interno di corpi lampada infatti esso emette onde elettromagnetiche ad alta frequenza (5,8GHz) e riceve il loro eco, in questo modo è in grado di riconoscere una qualsiasi variazione data da un oggetto non rilevato nella precedente analisi e verrà dato il comando di ON. La trasmissione ad alta frequenza è <10mW e risulta essere 100 volte inferiore alle emissioni di un comune telefono cellulare o di un forno a microonde che emettono mediamente 1000mW.

**Installazione: da incorporare**  
**Controllo di luminosità:** 10-300 lux 24h  
**Trasmissione di segnale:** <10mW  
**Consumo:** ± 0,9W  
**Sensibilità:** 2÷10m  
**Tempo:** 10 sec ÷ 30 min

**Microwave MOTION detector with crepuscular.** This technology allows the detector to be "hidden" within lamp bodies, in fact it emits electromagnetic waves at a high frequency (5.8GHz) and receives their echoes. In this way, it can recognise any variation given by an object not detected in the previous analysis and the ON command will be given. High frequency transmission is <10mW and is 100 times lower than the emissions of a common mobile phone or a microwave oven emitting an average of 1000mW.

**Installation: built-in use**  
**Light control:** 10-300 lux 24h  
**Transmission power:** <10mW  
**Power consumption:** ± 0,9W  
**Sensibility:** 2÷10m  
**Time:** 10 sec ÷ 30 min

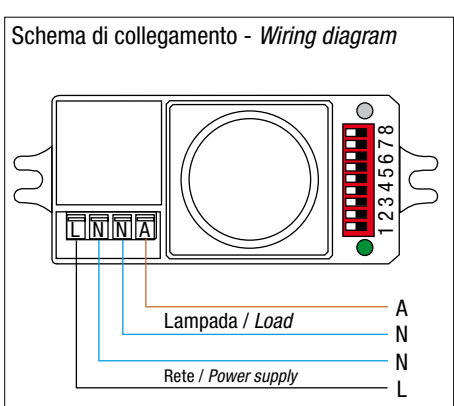
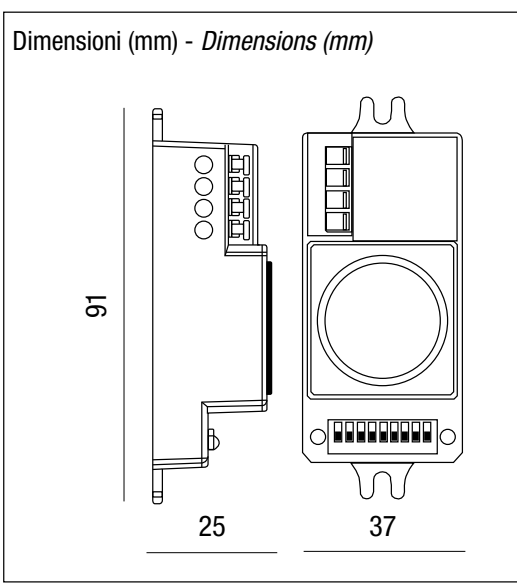

**Microswitch di settaggio - Specification setting**

1	Sensibilità - Sensitivity
2	Sensibilità - Sensitivity
3	Tempo - Time
4	Tempo - Time
5	Tempo - Time
6	Luminosità - Lux
7	Luminosità - Lux
8	Luminosità - Lux
9	Sensore - Sensor

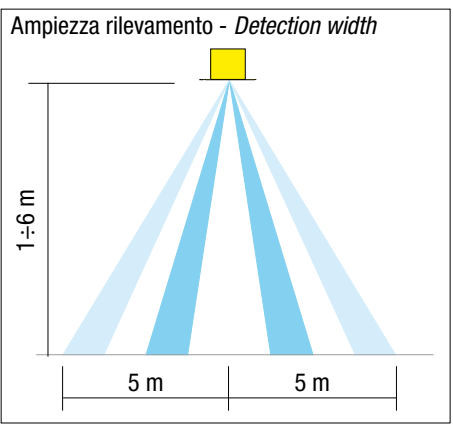
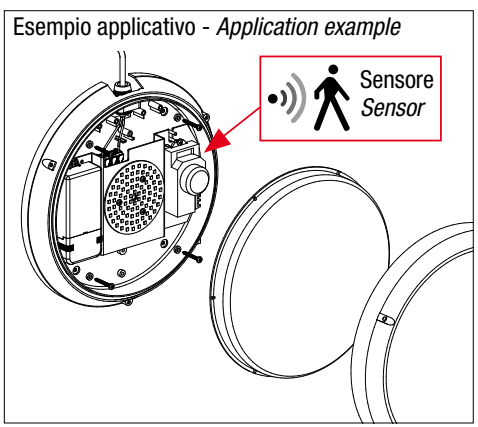

# 1-10V - RILEVATORI DI PRESENZA INFRAROSSI CON CREPUSCOLARE

## OCCUPANCY DETECTOR WITH LIGHT SENSOR

Con/ With  
Relè



Code	W	VA	n°	V	Hz	ta °C	PCS	CCM cm³
HIR22	500 *	250 *	max 15	220-240	50/60	-20...50	1	300

\* Per potenze superiori utilizzare un relè di appoggio - For higher powers use a external relay

**Rilevatore di PRESENZA ad infrarossi passivi con uscita 1-10V per la gestione di LED Driver dimmerabili con crepuscolare** per impostazione soglia Lux ambiente di intervento. Il sensore "percepisce" le variazioni di temperatura provocate dal movimento di persone o animali di grossa taglia entro la zona di copertura, accendendo e regolando automaticamente la luce in base al livello del LUX impostato.

Lo spegnimento si avrà, dopo l'arresto del movimento, in base al tempo precedentemente impostato. Grazie alle sue particolari lenti, il rilevatore, è in grado di **percepire non solo il movimento ma anche la PRESENZA** di uno o più individui all'interno dell'ambiente controllato. HIR22 consente di impostare una soglia di stand-by (switch rotativo) prima dello spegnimento completo (come da tabella 1).

Inoltre, con l'utilizzo del trasmettitore infrarossi opzionale (HRC-11), sarà anche ottenere molte altre impostazioni senza dover accedere fisicamente allo switch rotativo e cambiare quindi le impostazioni in base alle esigenze.

**Passive infrared PRESENCE detector with 1-10V output for dimmable LED Drivers; with twilight function for Lux threshold setting within the range of intervention.**

The sensor "perceives" variations in temperature caused by the movement of people or big animals within the covered area, which automatically turns on the light, which is also based on the previously set level of environmental LUX.

Shutdown will take place shortly after the motion within the range of detection stops, according to the previously set time.

Thanks to its particular lenses, the detector is able to **perceive not only the movement but also the PRESENCE** of one or more individuals within the controlled environment.

HIR22 allows a standby threshold (rotary switch) before complete shutdown (as indicated in table 1) to be set.

The optional infrared transmitter (HRC-11) also offers many other settings that do not require physical activation at the rotary switch or, therefore, changing according to needs.

Rilevatore di PRESENZA infrarossi  
Infrared PRESENCE detector

1-10Vdc



Dimensioni (mm) - Dimensions (mm)

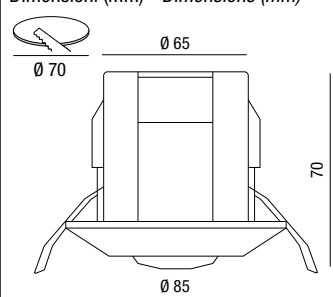

Ampiezza rilevamento - Detection width

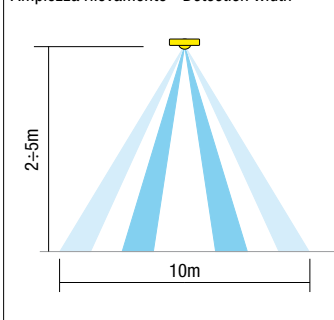

Angolo di rivelamento: 360°  
Altezza di montaggio: 2-5 metri  
Ampiezza rilevamento: Ø 10m  
Assorbimento stand by: < 0,5W

Detection angle: 360°  
Assembly height: 2-5 metres  
Detection Width: Ø 10m  
Stand-by absorption: < 0,5W



**Tabella 1** - Trimmer integrato per la selezione delle scene preimpostate  
**Table 1** - Rotary switch build inside the sensor for scene selection

Canali Channel	Tempo spegnimento Hold time	Stand by Tempo - Time	Stand by Livello regolazione Dimming level	Soglia Lux Daylight threshold
0	5 sec	10 sec	10%	/
1	1 min	5 min	10%	50 Lux
2	5 min	10 min	10%	50 Lux
3	5 min	+ ∞	10%	75 Lux
4	5 min	+ ∞	10%	100 Lux
5	5 min	+ ∞	30%	200 Lux
6	10 min	30 min	10%	50 Lux
7	10 min	+ ∞	10%	75 Lux
8	10 min	+ ∞	10%	100 Lux
9	10 min	+ ∞	30%	200 Lux
A	20 min	1 h	10%	100 Lux
B	20 min	+ ∞	30%	200 Lux
C	30 min	+ ∞	10%	100 Lux
D	30 min	+ ∞	30%	200 Lux
E	30 min	+ ∞	50%	400 Lux
F	5 sec	10 sec	10%	100 Lux

### Funzione di controllo della luce ambientale

Una volta impostati i LUX, il sensore esegue una comparazione tra la luce naturale (esterna) e quella artificiale (interna), regolando, tramite segnale 1-10Vdc, il driver al raggiungimento del livello luminoso desiderato.

### Daylight Harvest (Daylight Regulation)

Daylight sensor measures the available surrounding natural light, calculates how much electrical light is needed to reach the total lux expected. The demand is given to the LED driver by 1-10Vdc signal, so as to deliver the needed amount of electric light

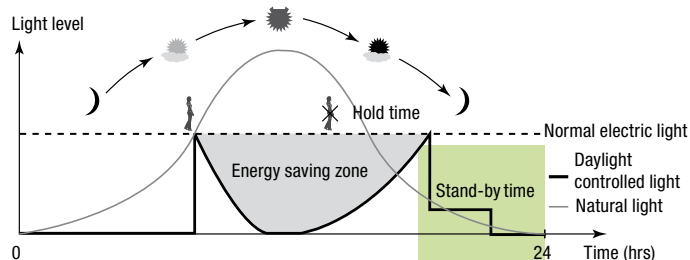

Impostazione del minimo livello di intensità luminosa  
Setting the minimum level of light intensity

**FUNZIONE OVERRIDE.** HIR22 dispone di un ingresso pulsante con il quale sarà possibile "forzare" accensione e spegnimento e regolare la luminosità.

**Pressione breve (<1s):** funzione ON/OFF

**ON / OFF:** la luce si spegne immediatamente e non può essere attivata su ON da movimento fino alla scadenza del tempo di attesa preimpostato, dopodiché il sensore riprenderà il suo normale funzionamento automatico.

**OFF / ON:** la luce si accende e passa alla modalità sensore, indipendentemente dal fatto che il livello Lux ambientale superi o meno la soglia diurna.

**Pressione prolungata (> 1s):** regola il livello di luminosità desiderato regolando la luce in alto o in basso. Sia la regolazione sul telecomando che l'interruttore a pulsante possono sovrascrivere l'un l'altro. L'ultima regolazione rimane in memoria

**OVERRIDE FUNCTION.** With the help of push-switch, this sensor maybe over-riden by the end-users to switch on/off the lights manually, or adjust the light brightness during motion hold-time. This makes the product more user-friendly and offers more options to fit for extra-ordinary demands.

**Short push (<1s):** on/off function;

**ON / OFF:** the light turns off immediately and cannot be lighten for a certain time (equals to hold time preset) even there is movement is detected. After this period, the sensor goes back to auto sensor mode.

**OFF / ON:** the light turns on 100% and goes to auto sensor mode, even when ambient Lux level exceeds the daylight threshold.

**Long push (>1s):** adjust the target lux level by turning the light up or down. Both the adjustment on remote control and push switch can overwrite each other, the last adjustment remains in memory.



Cod. HRC-11

Accessorio NON incluso

L'utilizzo del telecomando HRC-11 permette di modificare le impostazioni senza dover accedere direttamente al trimmer integrato

**NOT included accessory**

Using the HRC-11 remote control allows you to change the settings without having to directly access the integrated trimmer



cod. HBTDAP

Accessorio per montaggio a plafone

Ceiling mount accessory

# 1-10V - RILEVATORI DI MOVIMENTO MICRO ONDE CON CREPUSCOLARE

## MICRO WAVE MOTION DETECTOR WITH LIGHT SENSOR

Con/With  
Relè



Code	W	VA	n°	V	Hz	ta °C
HC018V	500 *	250 *	Max 15	220-240	50/60	-20...60

\* Per potenze superiori utilizzare un relè di appoggio - For higher powers use a external relay

Rilevatore di presenza a micro onde con crepuscolare per impostazione soglia LUX ambiente di intervento, uscita di controllo 1-10V, funzione corridoio, tutte le funzioni sono impostabili tramite DIP SWITCH.

Funzionamento a micro onde, questa tecnologia funziona con una emissione di onde elettromagnetiche ad alta frequenza (5,8 GHz) e eco di ritorno al dispositivo, in questo modo l'apparecchiatura è in grado di riconoscere una qualsiasi variazione data da un oggetto non rilevato nella precedente analisi e verrà dato il comando di ON.

La trasmissione ad alta frequenza è <10mW e risulta essere 100 volte inferiore alle emissioni di un comune telefono cellulare o di un forno a micro onde che emettono mediamente 1000mW.

**Funzione corridoio:** questa funzione permette di impostare un tempo e una soglia di stand-by durante il quale la lampada non si spegnerà completamente e subito, ma solo dopo il tempo impostato salvo nuove variazioni nell'ambiente controllato, ovviamente, per questa funzione, la lampada dovrà essere equipaggiata con driver 1-10V.

**Funzione OVERRIDE:** Il sensore dispone anche di un ingresso pulsante tramite il quale sarà possibile "forzare" accensione, spegnimento e regolazione della luminosità.

**Pressione breve (<1s):** funzione ON/OFF

**ON/OFF:** la luce si spegne immediatamente e non può essere attivata su ON da movimento, fino alla scadenza del tempo di attesa preimpostato, dopodiché il sensore riprenderà il suo normale funzionamento automatico

**OFF/ON:** la luce si accende e passa alla modalità sensore, indipendentemente dal fatto che il livello Lux ambiente superi o meno la soglia diurna.

**Pressione prolungata (>1s):** regola il livello di luminosità desiderato regolando la luce dal min al max.

*Microwave presence detector with twilight for setting the LUX threshold of the intervention environment, control output 1-10V, corridor function, all functions can be set via DIP SWITCH.*

*Microwave operation, this technology works with an emission of high frequency electromagnetic waves (5.8 GHz) and echoes back to the device, in this way the equipment is able to recognize any variation given by an undetected object in the previous analysis and the ON command will be given.*

*The high frequency transmission is <10mW and is 100 times lower than the emissions of a common mobile phone or a microwave oven which emit on average 1000mW.*

**Corridor function:** this function allows you to set a stand-by time and threshold during which the lamp will not turn off completely and immediately, but only after the set time, except for new variations in the controlled environment. lamp must be equipped with 1-10V driver.

**OVERRIDE function:** The sensor also has a pushbutton input through which it will be possible to "force" switch-on, switch-off and brightness adjustment.

**Short press (<1s):** ON / OFF function

**ON / OFF:** the light switches off immediately and cannot be turned ON by movement, until the preset waiting time expires, after which the sensor will resume its normal automatic operation

**OFF / ON:** the light turns on and switches to sensor mode, regardless of whether the ambient Lux level exceeds the daytime threshold or not.

*Long press (> 1s): adjusts the desired brightness level by adjusting the light from min to max.*

Rilevatore di PRESENZA micro onde  
Micro wave PRESENCE detector



Dimensioni (mm) - Dimensions (mm)

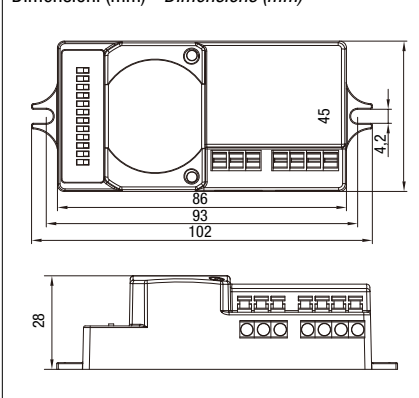

Ampiezza rilevamento - Detection width

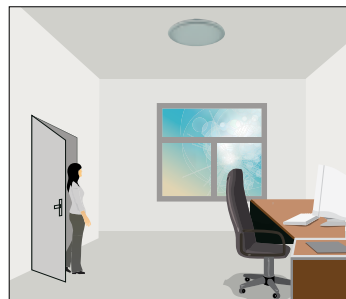
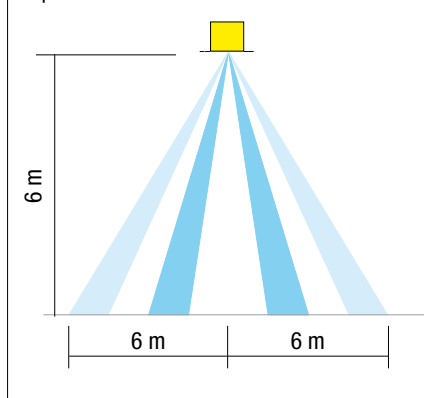

Con sufficiente luce naturale, la luce non si accende quando viene rilevata la presenza.  
With sufficient natural light, the light does not switch on when presence is detected

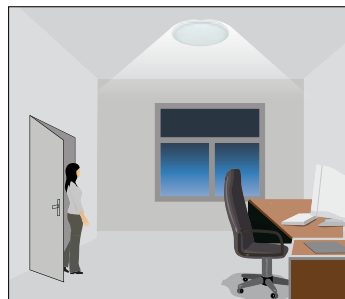

Con luce naturale insufficiente, il sensore accende automaticamente la luce quando viene rilevata la presenza.  
With insufficient natural light, the sensor switches on the light automatically when presence is detected.

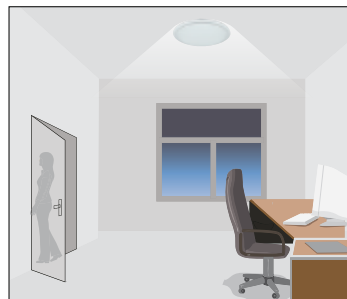

Dopo il tempo di attesa, la luce si attenua al livello di attesa predefinito.  
After hold-time, the light dims to stand-by level preset.

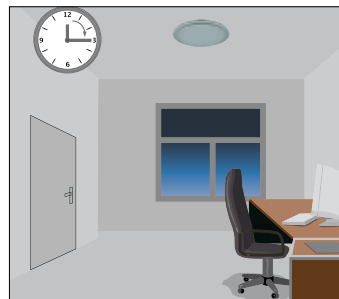

La luce si spegne automaticamente al termine del periodo di stand-by.  
Light switches off automatically after the stand-by period elapses.



# SENSORE DI MOVIMENTO MICROONDE CON CREPUSCOLARE

## MICROWAVE MOTION SENSOR WITH TWILIGHT



Code	Vac	Hz	L x P x H (mm)	Vdc OUT	Corrente in uscita Output current	Consumo stand-by Standby consumption	Ta °C	Tc °C
HCD418	220-240	50/60	102x45x28	15	32-40mA	< 0,5W	-35...70	80

**Rilevatore di movimento a microonde con crepuscolare** dotato di funzione tri-level (funzione corridoio), con possibilità di impostazione del rilevamento dei lux (2-50lux) e con livello di dimmerazione in stand-by impostabile (5% - 50%). Ideale per applicazioni di retrofitting, il funzionamento a microonde permette di "nascondere" il rilevatore anche all'interno di corpi lampada in quanto emette onde elettromagnetiche ad alta frequenza (5,8GHz) e riceve il loro eco; in questo modo è in grado di riconoscere qualsiasi variazione data dal rilevamento di nuovi elementi in movimento, per il quale verrà dato comando di ON. La trasmissione in alta frequenza è <2mW.

**Tempo di warming-up:** 20s

**Frequenza di operatività:** 5.8GHz +/- 75MHz

**Trasmissione di segnale:** <2mW

**Ampiezza di rilevamento:** massimo 12mt Ø x 5mt h

**Sensibilità:** 10% / 50% / 75% / 100%

**Tempo di funzionamento:** 30s - 30min (impostabile)

**Controllo luminosità:** 2-50lux, con possibilità di disinibizione

**Tempo di stand-by:** 0s - 1h, Infinito (impostabile)

**Dimmerazione in stand-by:** 5% / 10% / 20% / 50%

**Microwave motion detector with twilight sensor** equipped with tri-level function (corridor function), with the possibility of setting the lux detection (2-50lux) and with adjustable stand-by dimming level (5% - 50%). Ideal for retrofitting applications, the microwave operation allows the detector to be "hidden" even inside lamp bodies as it emits high-frequency electromagnetic waves (5.8GHz) and receives their echo; in this way it is able to recognize any variation given by the detection of new moving elements, for which an ON command will be given. The high-frequency transmission is <2mW. **Warm-up time:** 20s

**Operating frequency:** 5.8GHz +/- 75MHz

**Signal transmission:** <2mW

**Detection width:** maximum 12mt Ø x 5mt h

**Sensitivity:** 10% / 50% / 75% / 100%

**Operating time:** 30s - 30min (adjustable)

**Brightness control:** 2-50lux, with the possibility of disinhibition

**Stand-by time:** 0s - 1h, Infinite (adjustable)

**Dimming in stand-by:** 5% / 10% / 20% / 50%

Sensore di movimento micro onde  
Microwave motion sensor



Schema di collegamento - Wiring diagram

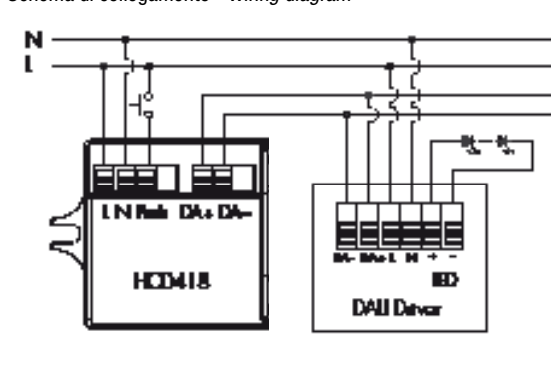

Ampiezza rilevamento - Detection width

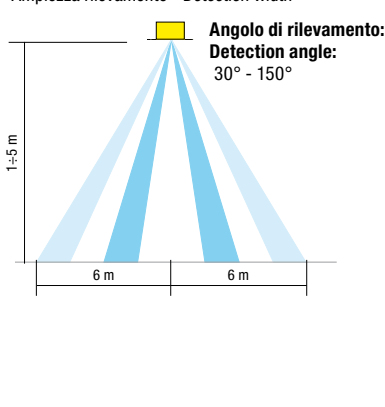

### VERRIDE MANUALE

Questo sensore riserva la funzione di override manuale per l'utente finale per accendere/spagnere o regolare la luminosità tramite interruttore a pulsante, rendendo il prodotto più user-friendly e offrendo più opzioni per alcune richieste straordinarie:

• Pressione breve (<1s): funzione on/off;

• On > Off: la luce si spegne immediatamente e non può essere riaccesa dal movimento fino alla scadenza del tempo di mantenimento preimpostato. Dopo questo periodo, il sensore torna alla modalità sensore normale.

• Off > On: la luce si accende e passa alla modalità sensore, indipendentemente dal fatto che il livello di Lux ambientale superi o meno la soglia di luce diurna.

• Pressione lunga (>1s): regola il livello di luminosità del tempo di mantenimento tra il 10% e il 100%.

Nota: se l'utente finale non vuole la funzione di override manuale, non deve cablare i morsetti della funzione "Push"

### MANUAL OVERRIDE

This sensor reserves the manual override function for end-user to turn on/off or adjust brightness by push button switch, making the product more user-friendly and providing more options for some extraordinary requests:

• Short press (<1s): On/off function;

• On > Off: The light turns off immediately and cannot be turned on by motion until the preset hold time expires. After this period, the sensor returns to normal sensor mode.

• Off > On: The light turns on and switches to sensor mode regardless of whether the ambient Lux level exceeds the daylight threshold or not.

• Long press (>1s): Adjust the hold time brightness level between 10% and 100%.

Note: If end-user does not want the manual override function, they should not wire the terminals of "Push"

### Funzione Corridoio (Funzione Tri-Level):

Il sensore offre 3 livelli di illuminazione: 100% - Luce dimmerata Off, ed è possibile impostare il tempismo di 2 periodi di tempo di attesa: mantenimento temporale a rilevamento movimento e periodo di stand-by. L'area di rilevamento ed il valore lux da rilevare sono impostabili a bordo sensore.

### Función de pasillo (función de tres niveles):

El sensor ofrece 3 niveles de iluminación: 100% - Luz atenuada Apagado, y puede configurar el tiempo de 2 períodos de espera: tiempo de retención de detección de movimiento y período de espera. En el sensor se pueden configurar el área de detección y el valor de lux a detectar.

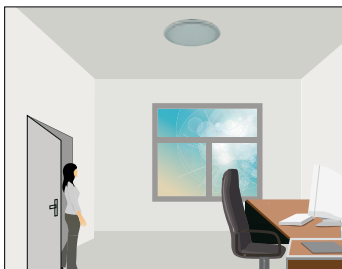

Con sufficiente luce naturale, la luce non si accende quando viene rilevata la presenza.

Con sufficiente luce naturale, la luce non si accende quando viene rilevata la presenza.

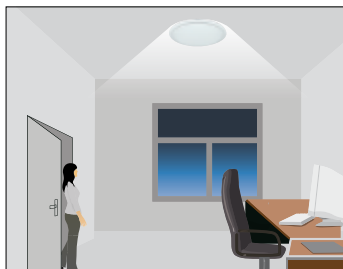

Con luce naturale insufficiente, il sensore accende automaticamente la luce quando viene rilevata la presenza.

Con poca luz natural, el sensor enciende automáticamente la luz cuando se detecta presencia.

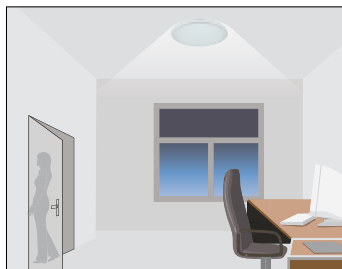

Dopo il tempo di attesa, la luce si attenua al livello di attesa predefinito.

Después del tiempo de espera, la luz se atenúa al nivel de espera predeterminado.



La luce si spegne automaticamente al termine del periodo di stand-by.

La luz se apaga automáticamente al final del período de espera.

# 1-10V - SENSORI DI LUMINOSITÀ - DAYLIGHT SENSOR

CE DIM IP20 1-10Vdc interfaccia passiva  
1-10Vdc interface passive

Code	V <sub>dc</sub>	I <sub>out</sub>	n°	ta °C	PCS	CCM cm <sup>3</sup>
ES-GL01	1-10	max 50mA	max 6	-20...50	1	40,62

## Sensore di luce ambientale per driver dimmerabili 1-10V

Realizzato con corpo in plastica e grado di protezione IP20. Questo sensore confronta la luce ambientale con quella impostata, tramite sistema di regolazione 1-10V è in grado di pilotare tutti i tipi di driver che accettano questo tipo di segnale. Aumentando o diminuendo la luce delle sorgenti luminose, consente di mantenere l'illuminazione ambientale costante. Il sensore dispone inoltre di un trimmer (A) per l'impostazione del livello di luminosità desiderato, questo sistema consente un notevole risparmio di energia con conseguente contenimento dei costi di gestione.

**Installazione:** da incorporare

**Tensione d'alimentazione:** 1÷10Vdc

**Potenza:** 50mA (max 6 driver)

**Livello di regolazione:** 10% - 100%

**Soglia di luce diurna:** 50-500Lux

**Lunghezza massima conduttori:** 30m

**Angolo di rilevamento:** 90°

## Ambient light sensor for 1-10V dimmable drivers

Made with a plastic body and a protection rating of IP20. This sensor compares ambient lighting with that set, by means of a 1-10V regulation system capable of driving all types of drivers which accept this type of signal. It keeps ambient lighting constant by increasing or decreasing the light of the light sources.

The sensor also has a trimmer (A) to set the desired brightness level. This system saves considerable energy and consequently, reduces management costs.

**Installation:** built-in use

**Power supply voltage:** 1÷10Vdc

**Power:** 50mA (max 6 driver)

**Adjustment level:** 10% - 100%

**Daytime light threshold:** 50-500Lux

**Maximum length of conductors:** 30m

**Detection angle:** 90°

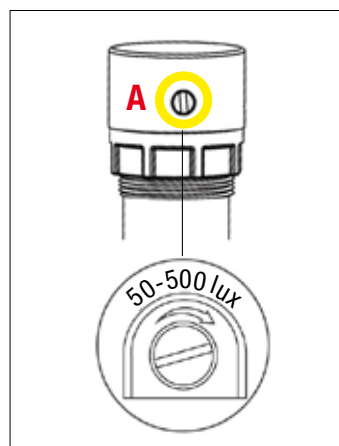
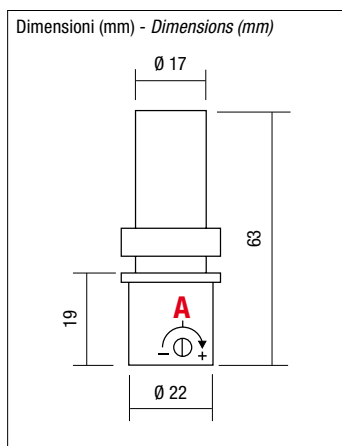

**A**  
Potenziometro per la regolazione del livello di luce.  
Potentiometer for adjusting target light level.

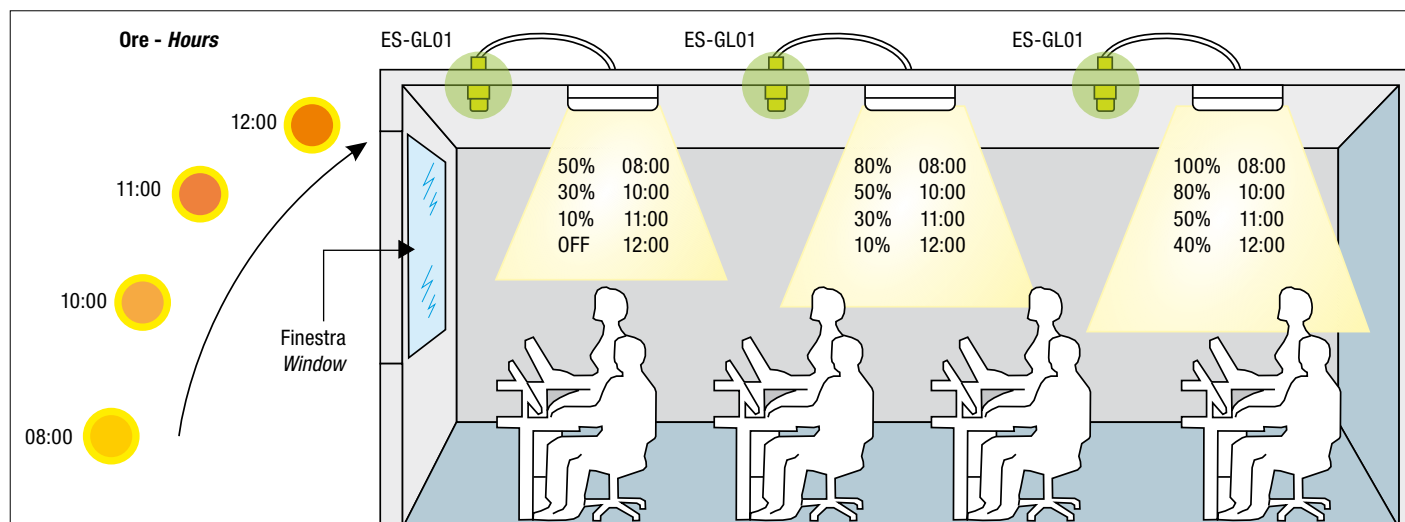

ES-GL01 è un sistema di controllo dell'efficienza energetica, facile da usare, sicuro e pratico. Il sensore adotta la tecnologia di regolazione 1-10Vdc. in grado di sfruttare al massimo la luce naturale per aumentare l'efficienza energetica e ridurre i consumi.

ES-GL01 is an easy to use, safe and practical energy efficiency control system. The sensor uses 1-10Vdc regulation technology capable of fully exploiting natural light to increase energy efficiency and to reduce consumption.

## Schema di collegamento - Wiring diagram

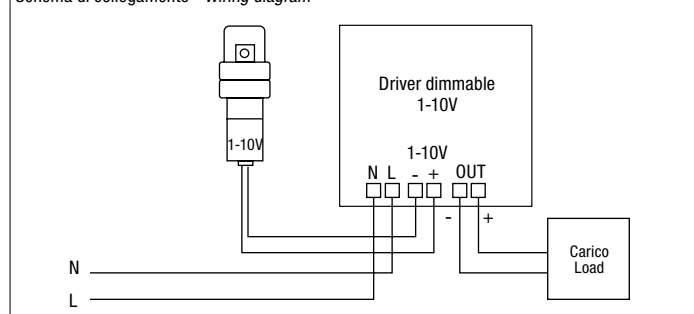

# MOBY SENT

## Rilevatore di presenza - *Occupancy detector*

Con/ With  
Relè

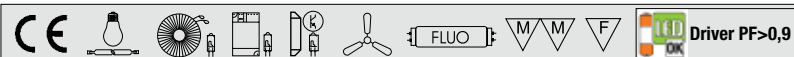

Code	W	VA	V	Hz	
RN0400/NEW	500	200	230	50/60	1

**Minirilevatore di movimento ad infrarossi passivi.** Percepisce le variazioni di temperatura provocate dal movimento di persone accendendo automaticamente la luce. Il sensore di rilevamento per mobili, grazie alle sue ridotte dimensioni (Ø 10mm), risulta essere praticamente invisibile.

Lo spegnimento si avrà dopo l'arresto del movimento nell'ambito di rilevamento dopo un tempo fisso di 45".

Angolo di rilevamento: 90° orizzontale e verticale.

Distanza di rilevamento: 3m.

Lunghezza cavo sensore max: 30 cm.

**Mini passive infrared motion detector.** Perceives the variations in temperature caused by the movement of people, which automatically turns on the light. Thanks to the reduced dimensions (Ø 10 mm) of the furniture detecting sensor makes it practically invisible.

Shutdown will take place after the motion within the range of detection stops, after a fixed time of 45".

Detection angle: 90° horizontal and vertical.

Detection distance: 3m.

Max sensor cable length: 30 cm.

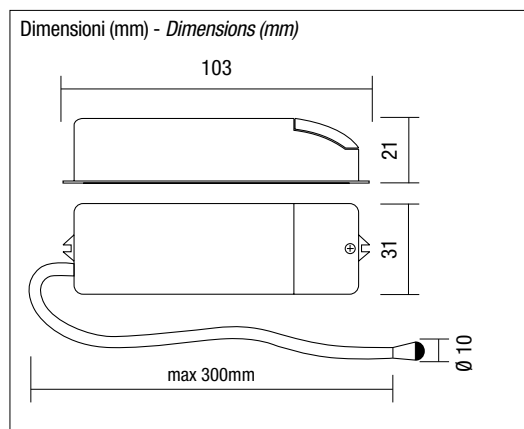
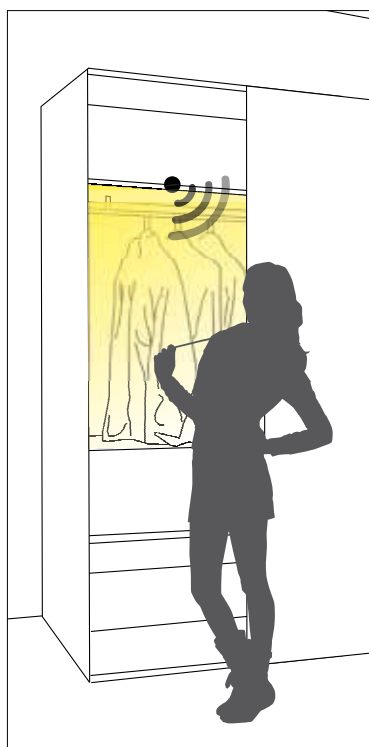

### Esempio applicativo

Ante dell'armadio APERTE (persona rilevata) = Luce ACCESA

Ante dell'armadio CHIUSE (persona non rilevata) = Luce SPENTA

### Application example

Cabinet door OPEN (detected person) = Light ON

Cabinet door CLOSED (NON detected person) = Light OFF

### Schema di collegamento - Wiring diagram

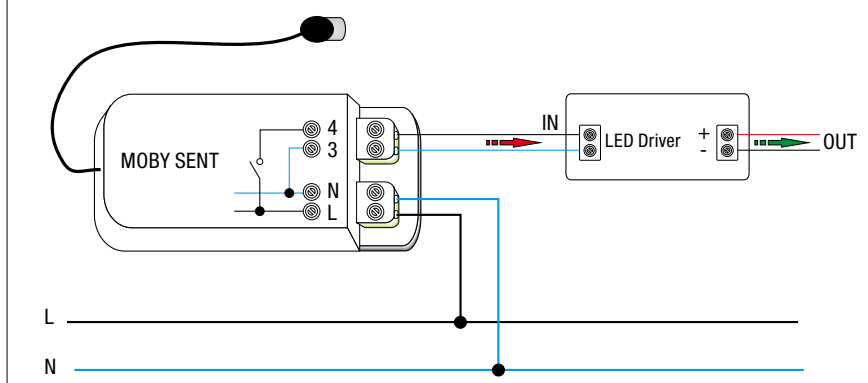

# DALI 2 - RILEVATORI DI PRESENZA INFRAROSSI CON CREPUSCOLARE

## OCCUPANCY DETECTOR WITH LIGHT SENSOR



Code	V <sub>dc</sub>	mA	ta °C	PCS	CCM cm <sup>2</sup>
HIR23/D2/R	9,5÷22,5	12	-20...50	1	300

Il sensore PIR e luce diurna autonomo HIR23/D2/R è stato certificato come dispositivo di ingresso DALI-2 con lo scopo principale di incorporarlo nel controller/master dell'applicazione DALI-2

*HIR23/D2/R stand-alone PIR & daylight sensor have been certified as DALI-2 input device with main purpose to incorporate into DALI-2 application controller / master*

- 2-in1: sensore di movimento PIR + sensore di luce diurna
- Scatola per montaggio a soffitto/parete IP20 disponibile come accessorio
- 2 tipi di inserto cieco per lenti PIR
- Design intuitivo per l'installazione
- Conforme alle Norme: IEC62386-101; 103; 303; 304
- Range Lux >1000 Lux
- Riscaldamento: 5 secondi
- Identificare il dispositivo: il LED rosso lampeggia 15S
- Consumo corrente DALI BUS: max 10 mA (senza LED) - max 12 mA (con LED)

- 2-in: PIR motion sensor + Daylight sensor
- IP20 ceiling/surface mount box available as accessory
- 2 kinds of PIR lens blind insert options
- User friendly design for installation
- Compliant to Standard: IEC62386-101 ; 103 ; 303 ; 304
- Lux reading range > 1000 Lux
- Warming-up : 5S
- Denify device : red LED flashed 15S
- Consumption DALI BUS current : max 10 mA (no LED) - max 12 mA (con LED)

**PER UN CORRETTO FUNZIONAMENTO DEL SENSORE È OBBLIGATORIO UTILIZZARE DEI CONTROLLER PER APPLICAZIONI DALI-2 AD ESEMPIO : SCENE COM (TRIDONIC), DLC-02 (MEAN WELL), 950 ROUTER (HELVAR)**

**FOR CORRECT OPERATION OF THE SENSOR IT IS MANDATORY TO USE CONTROLLERS FOR DALI-2 APPLICATIONS FOR EXAMPLE: SCENE COM (TRIDONIC), DLC-02 (MEAN WELL), 950 ROUTERS (HELVAR)**

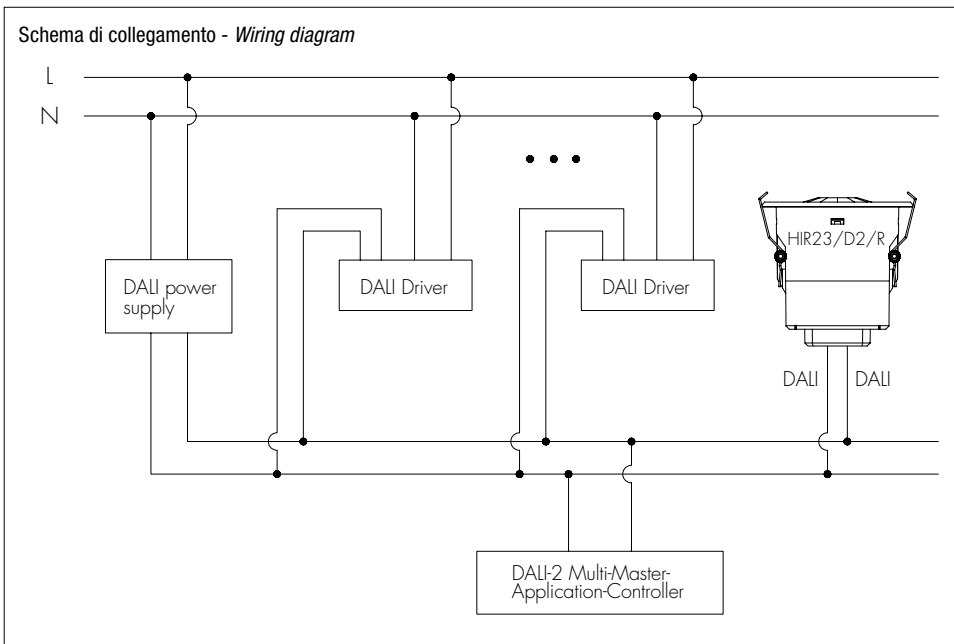
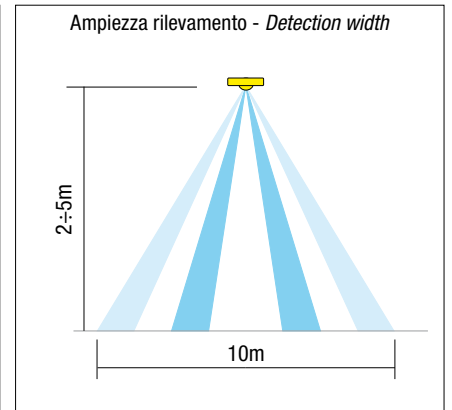
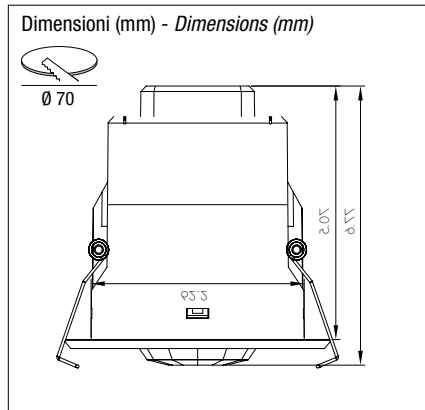

cod. HBTDP  
Accessorio per montaggio a plafone  
Ceiling mounting accessory

**Nota:** HIR23/D2/R è stato utilizzato come dispositivo di input DALI-2 solo per indicare il segnale DALI (del sensore di luce e del sensore di movimento) al controller DALI-2 e la funzione assegnata di indirizzamento, raggruppamento, DIM, ON/OFF ecc... verrà configurata tramite il controller dell'applicazione DALI-2, che è il "cervello principale" per processare la comunicazione dati tra i dispositivi di input e l'alimentatore.

**Note:** HIR23/D2/R was used as a DALI-2 input device only to indicate the DALI signal (of light sensor and motion sensor) to the DALI-2 controller and the assigned function of addressing, grouping, DIM, ON/OFF etc... will be configured via such DALI-2 application controller, which is the "main brain" for processing data communication between the input devices and the power supply.

## L'unica compatta a norme

La serie ASTRA nasce da una lunga esperienza e possiede le caratteristiche di affidabilità, di alte prestazioni, di facile impiego e di dimensioni ridotte. La serie ASTRA è composta da apparecchi modulari che possono essere montati su placche autoportanti per scatole tonde, su telai per scatole rettangolari e su custodie per installazione su parete. I componenti della serie ASTRA soddisfano le prescrizioni di sicurezza vigenti e i principali apparecchi sono conformi alle norme CEI ed approvati dall'Istituto Italiano del Marchio di Qualità.

## Il montaggio degli apparecchi

Gli apparecchi della serie ASTRA vengono montati a scatto posteriormente nelle apposite sedi delle calotte, delle custodie da parete, delle placche autoportanti e dei telai.

## Le dimensioni

Le ridotte dimensioni degli apparecchi della serie ASTRA hanno permesso di realizzare custodie per installazione su parete con una sporgenza dal muro di 32mm, una larghezza di 51mm, ed una lunghezza di 66mm. Nonostante queste ridotte dimensioni il limitato ingombro degli apparecchi permette di avere, anche in queste custodie, un ampio spazio per i conduttori di alimentazione. Le custodie sono predisposte per permettere il collegamento con cavi piatti 4x8mm, con canaline 10x20mm e con tubi Ø 16mm.

Nella serie ASTRA da incasso la sporgenza massima degli apparecchi oltre la superficie del muro all'interno delle scatole è di soli 20mm. Usando scatole unificate di 45mm o di 50mm di profondità si hanno perciò a disposizione rispettivamente 25mm o 30mm per un ampio alloggiamento dei conduttori di alimentazione.

## I morsetti

Per gli interruttori, i deviatori e i pulsanti, sono stati adottati morsetti con piastrina di serraggio ed ingresso laterale dei conduttori da due lati. Questa soluzione, oltre a garantire un efficiente ed agevole cablaggio, facilita l'eventuale interconnessione di apparecchi affiancati. Tutti gli altri apparecchi sono dotati di morsetti a bussola.

## The only compact series according to laws

ASTRA range rises from a long experience and holds reliability characteristics, high performances, an easy employment and reduced sizes. ASTRA range is composed by modular equipments that may be mounted on autosupporting plates for round boxes, on frame for rectangular boxes and on cases for surface mounting.

ASTRA range components are in conformity with the laws and principal equipments are in conformity with CEI laws and approved by the Quality Marking Italian Institute.

## Equipments assembly

ASTRA range equipments are assembled with a recoil movement in the backside of the dome, of the surface cases, of the autosupporting plates and of the frames.

## Sizes

Reduced sizes of ASTRA range equipments have made possible to realize cases for surface mounting with a prominence from the wall of 32mm, a width of 51mm and a length of 66mm. The reduced equipment sizes enable also in these cases to have the right place for the input conductors. The cases are made ready to allow the connection with flat cables 4x8mm, with lines 10x20mm and with tubes Ø 16mm.

In the flush mounting ASTRA range the maximum equipment prominence from the wall surface into the boxes is of only 20mm.

With the employment of the unified boxes of 45mm or of 50mm depth it will be possible to obtain respectively 25mm or 30mm for a wide lodging of input conductors.

## Terminals

For switches and push switches are in use terminals with locking plate and lateral entry of the conductors from both sides.

This solution, besides assuring an efficient and easy wiring, makes easier a possible equipments interconnection.

All the others equipments have screws terminals.

Per la regolazione vedi Pag. 641

For the regulation see Pag. 641



Custodia a 1 o 2 moduli da parete  
1 or 2-module wall-mounted housing



Serie per l'installazione da parete con placca autoportante a 1 o 2 moduli  
Series for wall installation with plate self-supporting with 1 or 2 modules



Serie da incasso per scatola rettangolare  
Flush mounting range for rectangular box

## Scatole, supporti, placche e placche AUTOPORTANTI - Boxes, supports, plates and AUTO-SUPPORTING plates

Article Code	Color	PCS	CCM cm <sup>3</sup>
1643	Bianco - White	25	4.387
1643-L-GS	Grigio scuro Dark gray	25	4.387
1643-L-BL	Blu - Blue	25	4.387
1643-L-VE	Verde - Green	25	4.387

Placca 3 moduli per scatola rettangolare  
Cover plate three openings for rectangular box

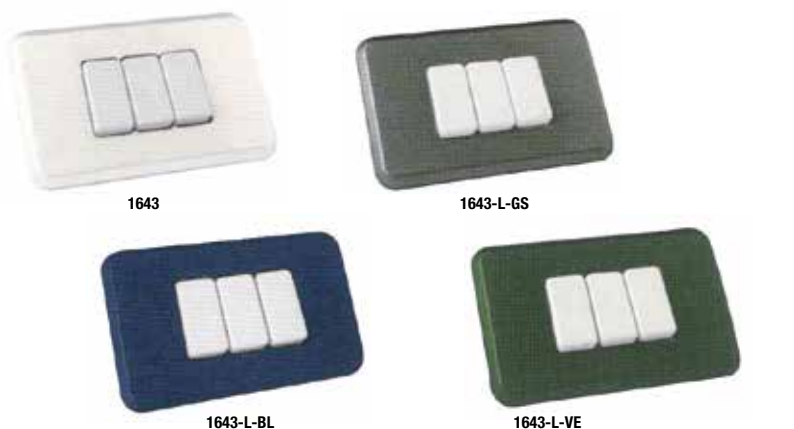

Article Code	Color	PCS	CCM cm <sup>3</sup>
1441	White	10	2.352

Placca **AUTOPORTANTE** - 1 posto - Fissaggio con griffe - Per scatola tonda Ø 60mm  
**AUTO-SUPPORTING plate** - One opening - Fixing by claws - For round box Ø 60mm



Article Code	Color	PCS	CCM cm <sup>3</sup>
1442	White	10	2.352

Placca **AUTOPORTANTE** - 2 posto - Fissaggio con griffe - Per scatola tonda Ø 60mm  
**AUTO-SUPPORTING plate** - Two opening - Fixing by claws - For round box Ø 60mm

## Scatole, supporti e custodie 1 o 2 moduli - Boxes, supports and 1 or 2 module box



Article Code	Color	PCS	CCM cm <sup>3</sup>
1660	■ Nero	50	3.187

Supporto 3 moduli con viti colore nero - Per scatole rettangolari - Con diaframma isolante sfondabile  
*Support for three openings plate in black color - For rectangular box - With breakable insulating diaphragh*

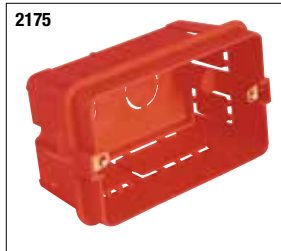

Article Code	LPH	PCS	CCM cm <sup>3</sup>
2175	93x55x50	12	3.300

Sacatola rettangolare in Tecnopolimero con 2 inserti metallici - Interasse fori 83,5mm - Confezione in termoretraibile  
*Technopolymer rectangular box with two threaded metal parts - Distance between fixing centres 83,5mm - Wrapping in therm-retractile plastic*



Article Code	Color	PCS	CCM cm <sup>3</sup>
1541	□ White	50	6.545

Custodia 1 modulo IP20 - Installazione da parete - Chiusura con viti - Dimensioni: 51x66x33mm  
*Box IP 20 1 module - Surface mounting - Closure with screws - Size: 51x66x33mm*



Article Code	Color	PCS	CCM cm <sup>3</sup>
1542	□ White	50	6.545

Custodia 2 modulo IP20 - Installazione da parete - Chiusura con viti - Dimensioni: 51x66x33mm  
*Box IP 20 2 module - Surface mounting - Closure with screws - Size: 51x66x33mm*

## Apparecchi di comando non automatici - Not automatic control devices



Article Code	Color	PCS	CCM cm <sup>3</sup>
1600	□ White	50	2.760

Interruttore unipolare 250V~ 1P 10A  
*Single pole one way switch 1P 250V~ 10A*



Article Code	Color	PCS	CCM cm <sup>3</sup>
1601	□ White	50	2.760

Deviatore unipolare 250V~ 1P 10A  
*Single pole two-way switch 1P 250V~ 10A*



Article Code	Color	PCS	CCM cm <sup>3</sup>
1604	□ White	50	2.294

Pulsante unipolare tirante 250V~ 1P NO 2A. Con 1,5 m cordone e pomello  
*Single pole pull cord switch 1P NO 250V~ 2A. With cord of 1,5 m.*



Article Code	Color	PCS	CCM cm <sup>3</sup>
1605	□ White	50	2.760

Pulsante unipolare a leva 250V~ 1P NO 2A.  
*Single pole lever push switch 1P NO 250V~ 2A.*

## Prese per installazione fissa - Socket for fixing installation



Article Code	Color	PCS	CCM cm <sup>3</sup>
1651	□ White	50	2.760

Preso standard italiano P11, 2P + T 106A 250V~  
*Italian standard socket outlet P11, 2P + T 10A 250V~*



Article Code	Color	PCS	CCM cm <sup>3</sup>
1656	□ White	50	2.760

Preso standard italiano P17/11 2P + T 16A 250V~  
*Italian standard socket outlet P17/11 2P + T 16A 250V~*

## Accessori - Accessories



Article Code	Color	PCS	CCM cm <sup>3</sup>
1606	□ White	50	2.760

Modulo uscita cavo  
*Exit cable clamp*



Article Code	Color	PCS	CCM cm <sup>3</sup>
1645	□ White	50	2.760

Modulo tasto con copriforo  
*Closing cap*

# SERIE 2000

## Prodotti da installazione - *Installation products*

### Scatole di derivazione componibili - *Componible distribution boxes*

2002-SC



Article Code	LPH mm	PCS	CCM cm <sup>3</sup>
2002-SC	92x92x47	12	6.000

Scatola in Tecnopolimero - Per coperchio art. C-2002 - Confezione in termoretraibile  
*Technopolymer box - For cover art. C-2002 - Wrapping in therm-retractile plastic*

2003-SC



Article Code	LPH mm	PCS	CCM cm <sup>3</sup>
2003-SC	134x92x47	10	7.000

Scatola in Tecnopolimero - Per coperchio art. C-2003-4 - Confezione in termoretraibile  
*Technopolymer box - For cover art. C-2003-4 - Wrapping in therm-retractile plastic*

2004-SC



Article Code	LPH mm	PCS	CCM cm <sup>3</sup>
2004-SC	134x92x67	8	7.840

Scatola in Tecnopolimero - Per coperchio art. C-2003-4 - Confezione in termoretraibile  
*Technopolymer box - For cover art. C-2003-4 - Wrapping in therm-retractile plastic*

2005-SC



Article Code	LPH mm	PCS	CCM cm <sup>3</sup>
2005-SC	184x134x67	5	8.977

Scatola in Tecnopolimero - Per coperchio art. C-2005-6 - Confezione in termoretraibile  
*Technopolymer box - For cover art. C-2005-6 - Wrapping in therm-retractile plastic*

# SERIE 2000

## Prodotti da installazione - *Installation products*

### Coperchi con viti di fissaggio - *Cover with fixing screws*

C-2002



Article Code	LPH mm	PCS	CCM cm <sup>3</sup>
C-2002	108x108x3	50	11.760

Per scatola 2002-SC - *For boxes 2002-SC*

C-2003-4



Article Code	LPH mm	PCS	CCM cm <sup>3</sup>
C-2003-4	200x150x2	20	11.760

Per scatola 2003-SC e 2004-SC  
*For boxes 2003-SC and 2004-SC*

C-2005-6



Article Code	LPH mm	PCS	CCM cm <sup>3</sup>
C-2005-6	200x150x2	20	11.760

Per scatola 2005-SC - *For boxes 2005-SC*

C-2007





Article Code	LPH mm	PCS	CCM cm <sup>3</sup>
C-2007	295x150x2	10	11.760

Per scatola 2007-SC - *For boxes 2007-SC*



# SERIE 2000

## Prodotti da installazione - *Installation products*





Article Code		PCS 	CCM cm <sup>2</sup>
C-2008	390x150x2	20	11.760





Article Code		PCS 	CCM cm <sup>2</sup>
C-2009	425x200x2	10	11.760





Article Code		PCS 	CCM cm <sup>2</sup>
C-2010	560x200x2	10	11.760





Article Code		PCS 	CCM cm <sup>2</sup>
C-2011	285x200x2	20	11.760



Article Code		PCS 	CCM cm <sup>2</sup>
C-2175	123x78x2	25	11.760





Article Code		PCS 	CCM cm <sup>2</sup>
C-2265	102x102x2	50	11.760

Coperchio in Tecnopolimero con griffe di espansione.

*Techno-polymer cover with expansion claws.*





Article Code		PCS 	CCM cm <sup>2</sup>
C-2266-7	125x110x2	50	11.760

Coperchio in Tecnopolimero con griffe di espansione.

*Techno-polymer cover with expansion claws.*





Article Code		PCS 	CCM cm <sup>2</sup>
C-2268	162x110x2	30	11.760

Coperchio in Tecnopolimero con griffe di espansione.

*Techno-polymer cover with expansion claws.*

### Coperchi con viti di fissaggio per scatola tonda - *Cover with fixing screws for round box*





Article Code		PCS 	CCM cm <sup>2</sup>
2156	Ø90x2	50	6.602

Coperchio tondo in Tecnopolimero Ø 90mm - Bordo sporgente - Griffe di espansione.

*Techno-polymer round cover Ø 90mm - Protruding border - Expansion claws.*



Article Code		PCS 	CCM cm <sup>2</sup>
2155	Ø75x2	50	4.397

Coperchio tondo in Tecnopolimero Ø 75mm - Bordo sporgente - Griffe di espansione.

*Techno-polymer round cover Ø 75mm - Protruding border - Expansion claws.*

# CONDENSATORI PER LAMPADE A SCARICA per illuminazione 250Vac CAPACITORS FOR DISCHARGE LAMPS for lighting 250Vac

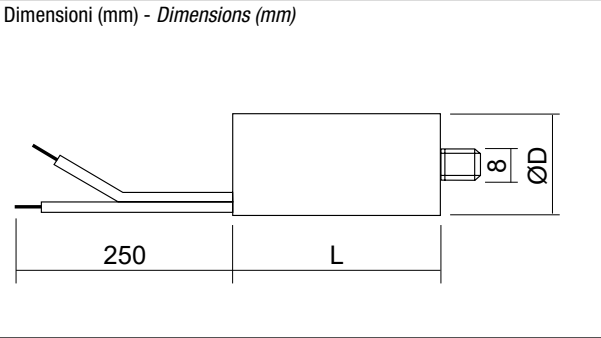

**Per illuminazione 250Vac**  
Condensatori di rifasamento con tensione di targa 250 o 450Vac, 50Hz, temperatura di impiego -25.. + 85°C, custodia in materiale plastico autoestinguente.

**For lighting 250Vac**  
Power factor corrected capacitors with plate power of 250 or 450Vac, 50Hz, temperature range -25.. + 85°C, plastic self-extinguishing casing

Article	$\mu\text{F}$ rifasam.	$\varnothing$ D mm	L mm		PCS		CCM cm <sup>3</sup>	Code
N02	2	25	56,5	26	162		2.916	S53901
N05	5	25	69,5	38	162		3.402	S53905
N06	6,3	25	69,5	52	162		3.402	S53906
N08	8	30	69,5	52	110		2.464	S53907
N14	14	35	69,5	88	86		2.227	S53910
N18	18	35	93,5	112	86		3.440	S53913
N20	20	35	93,5	142	86		3.440	S53915
N25	25	40	94,5	142	60		2.580	S53917
N30	30	40	94,5	178	60		2.580	S53919
N30/MPH	30	40	72	130	60		2.580	S53919/MPH
N30/M	30	40	94,5	178	60		2.580	S53919/M
N35	35	45	94,5	244	50		2.350	S53921
N40	40	45	94,5	244	50		2.350	S53923
N45/M	45	45	94,5	244	50		2.350	S53922/M
N50	50	50	94,5	322	40		2.200	S53925
N60/4	60	45	125	260	40		2.750	S53927/MPH

# CONDENSATORI PER per motori 450Vac CAPACITORS FOR motors 450Vac



Dimensioni (mm) - Dimensions (mm)

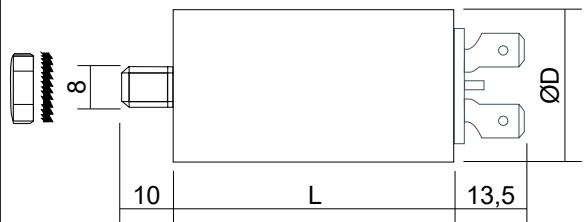

**Per motori 450Vac, con connessione Faston 6,3x0,8**

Valori di capacità diversa da quelli sotto riportati possono essere ottenuti mettendo in parallelo più condensatori (es. 60 µF = 40+20 oppure 30+30)

**For motors 450Vac, with faston connection 6,3x0,8**

Different capacity values to the above here mentioned can be obtained by placing several capacitors in parallel (ex. 60 µF = 40+20 or 30+30)

Article	µF rfesam	Ø D mm	L mm	GT	PCS	CBM m <sup>3</sup>	Code
N04/4	4	25	56,5	45	162	2.916	S53937
N06/4	6	30	56,5	45	110	2.695	S53941
N08/4	8	35	56,5	55	86	2.064	S53943
N10/4	10	35	56,5	70	86	2.064	S53945
N12/4	12	35	73,5	85	86	2.545	S53947
N14/4	14	35	73,5	100	86	2.545	S53949
N16/4	16	35	73,5	130	86	2.545	S53951
N18/4	18	40	73,5	135	60	1.909	S53953
N20/4	20	40	73,5	135	60	1.909	S53955
N25/4	25	45	74	160	50	1.739	S53957
N30/4	30	45	74	220	50	1.739	S53959
N40/4	40	45	94,5	250	50	2.256	S53960
N50/4	50	50	121	250	40	2.750	S53961

# TRASFORMATORI ELETTRONICI - *ELECTRONIC TRANSFORMERS*

Per bassissima tensione - *For low voltage*

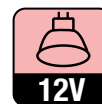

## MICRO 60 PFS



Article	Code	W min. max.	ta °C	tc °C	W	LPH mm	IN OUT	PCS	CCM cm <sup>3</sup>
MICRO 60 PFS	RN1608	10÷60	-15..+40	80	C	103x31x21	2 - 2	25	3.072

Trasformatori elettronici di dimensioni ridotte per lampade alogene a bassissima tensione, entrata e uscita sullo stesso lato.  
 Uso indipendente  
*Electronic transformers for independent use on very low voltage lamps. Approved according to electric appliances standard.  
 Reduced dimensions and weight.*

## FOX...



Article	Code	W min. max.	ta °C	tc °C	W	LPH mm	IN OUT	PCS	CCM cm <sup>3</sup>
FOX 105 PFS TH	RN1600	20÷105	-15..40	100	L - C	124x39x28	2 - 2	25	1.706
FOX 150 PFS TH	RN1684	50÷150	-15..40	85	L - C	149x50x33	2 - 2	25	1.729

## ICE...



Article	Code	W min. max.	ta °C	tc °C	W	LPH mm	IN OUT	PCS	CCM cm <sup>3</sup>
ICE 200 PFS TH	RN1614	100÷200	-15..40	90	L - C	185x46x38	4 - 6	-	-



# Portalampada smontati in Bachelite

## Douilles en bakélite démontées

Bachelite 3 pezzi E27 smontato - Bakélite 3 pièces E27 démontée



Norme di riferimento - Normes de référence EN 60238



**Portalampada smontato T 190** - morsetti a vite o automatici - componenti in 3 imballi separati.

**Unassembled lampholder T190** - screw or push in terminals - Components in 3 separated boxes

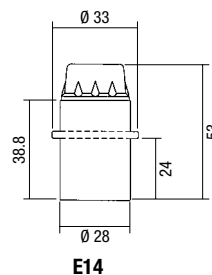

E14

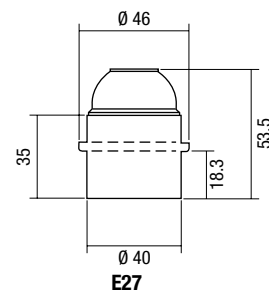

E27



U

### PST/7000 E27 - 4A - 250V - T190

Pastiglia in termoplastico - morsetti a vite T190 - Screw terminals T190 thermoplastic contact base

Codice articolo Article code		PCS	CCM cm <sup>3</sup>	
PST/7000/M1	N	1000	11.662	5,40

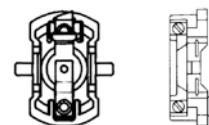

U

### PST/7000/H4/N E27 - 4A - 250V - T250V

Pastiglia in termoplastico con interruttore 144 - Thermoplastic contact base with 144 switch

Codice articolo Article code		PCS	CCM cm <sup>3</sup>	
PST/7000/H4/N	N	1000	11.662	10,7



U

### PST/7000/H/T E27 - 4A - 250V - T250V

Pastiglia in termoplastico con interruttore 200 - Thermoplastic contact base with 200 switch

Codice articolo Article code		PCS	CCM cm <sup>3</sup>	
PST/7000/H/T	N	1000	11.662	10,7



P

### 7175/E

Camicia E27 corpo liscio - E27 skirt smooth body

Codice articolo Article code		PCS	CCM cm <sup>3</sup>	
CAM/7175/E	N	1000	64.980	18,40

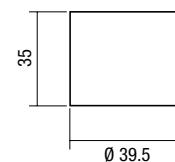

P

### 7200/E

Camicia E27 corpo filettato - E27 skirt threaded body

Codice articolo Article code		PCS	CCM cm <sup>3</sup>	
CAM/7200/E	N	1000	64.980	17,00

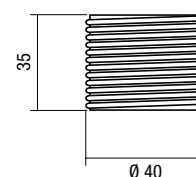



### 7350/E

Camicia E27 corpo 1/2 filettato - E27 skirt half threaded body

Codice articolo Article code		PCS	CCM cm <sup>3</sup>	
CAM/7350/E	N	1000	64.980	21,10

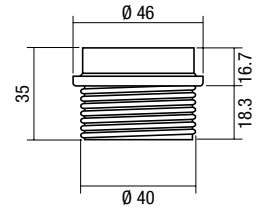

P



### 7000 - E27

Cappello con nippel in metallo M10x1 - Metal nut M10x1 cap

Codice articolo Article code		PCS	CBM cm <sup>3</sup>	
CAP/7000	N	1000	34.656	14,50

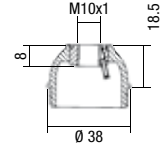

P



### 7000/T - E27

Cappello con nippel in metallo M10x1 e morsettura  
Metal nut M10x1 cap with earth terminal

Codice articolo Article code		PCS	CCM cm <sup>3</sup>	
CAP/7000/T	N	1000	34.656	17,50

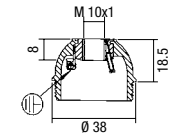

P



### 7000/H4 - E27

Cappello con nippel in metallo M10x1  
Metal nut M10x1 cap

Codice articolo Article code		PCS	CCM cm <sup>3</sup>	
CAP/7000/H4	N	1000	34.656	27,00

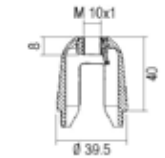

P



### 7000/HT - E27

Cappello con nippel in metallo M10x1  
Metal nut M10x1 cap

Codice articolo Article code		PCS	CCM cm <sup>3</sup>	
CAP/7000/HT	N	500	34.656	34,5

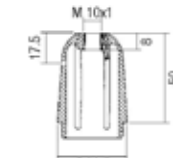

P



### 7000/H - E27

Cappello con nippel in metallo M10x1  
Metal nut M10x1 cap

Codice articolo Article code		PCS	CCM cm <sup>3</sup>	
CAP/7000/H	N	500	34.656	34,5

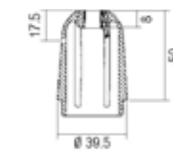

P



## Bachelite 3 pezzi smontati con interruttore a tirette - *Unassembled bakelite 3 pieces with pull switch*



### 7000/HT E27 - 2A - 250V

Portalamпада smontato in imballo unico. Cappello con raccordo metallico M10x1 - Interruttore a tirette con morsetti a vite

*Unassembled lampholder in one box. Cap with metallic insert M10x1 - Pull cord switch with screw terminals*

Codice articolo Article code		PCS	CCM cm <sup>3</sup>		
5095 1/2 filettato / Half threaded	N	25	7.546	250	64,60

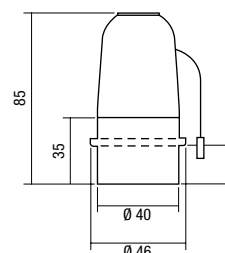



## Bachelite 3 pezzi smontati con interruttore - *Unassembled bakelite 3 pieces with switch*



Portalamпада smontato in imballo unico. Cappello con raccordo metallico M10x1 - interruttore a bilancere con morsetti a vite.

*Unassembled lampholder in one box. Cap with metallic insert M10x1 - Rocker switch with screw terminals*

FOTO	Codice articolo Article code		PCS	CCM cm <sup>3</sup>	
1	CAM/7175/E	N	1000	64.980	18,40
2	PST/7000/H4/N	N	1000	7.546	10,70
3	CAP/7000/H4	N	1000	64.980	27,00

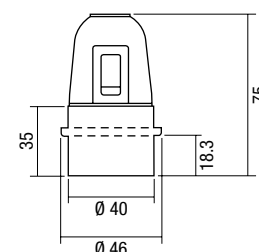



## Portalamпада e accessori E14 ed E27 - *E14 and E27 lamp holders and accessories*



### 5060 E27 - 4A - 250V

Portalamпада montato - Morsetti a vite + Camicia liscia + Cappello con filetto stampato M10x1

*Assembled lampholder - Screw terminals + Smooth + Cap with moulded thread M10x1*

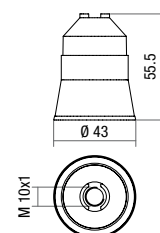

Codice articolo Article code		PCS	CCM cm <sup>3</sup>		
5060-N	N	100	10.633	1000	24,00
5060-A	B	100	10.633	1000	24,00



### 5080 E14 - 2A - 250V

Portalamпада montato - Morsetti a vite + Camicia + Cappello con filetto stampato M10x1.

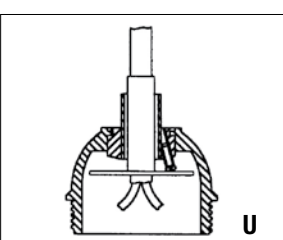
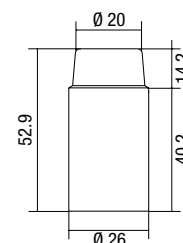

*Assembled lampholder - Screw terminals + Cap with moulded thread M10x1.*

Codice articolo Article code		PCS	CCM cm <sup>3</sup>		
5080E-N	N	100	8.918	1000	18,00
5080E-A	B	100	8.918	1000	18,00



### Isolatori - Isolators

307 - Per cappellotti E14 Bachelite - *For caps E14 series Bakelite* - 302 - Per cappellotti E27 Bachelite - *For caps E27 series Bakelite.*

Codice articolo Article code		PCS	CCM cm <sup>3</sup>	
307/B	B	3000	8.918	0,30
302/B	B	2000	8.918	0,60

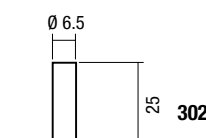

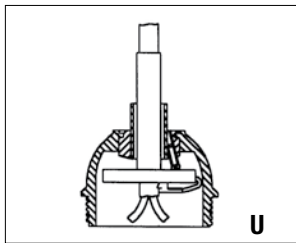

### 344 - Serrafilo con vite - Grub screw cord grip

Per cappellotti E14/E27 con filetto M10x1 - Lunghezza 10mm - Per cavo H03VVH2-F e H03VV-F.  
For caps E14/E27 threaded caps M10x1 - Length 10mm - For cable H03VVH2-F and H03VV-F.

Codice articolo Article code		PCS	CCM cm <sup>3</sup>	
344/BB	B	5000	21.660	2,50
344/N	N	5000	21.660	2,50

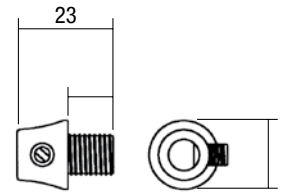

## Ghiere per portalampada E14 - E27 - Shade rings for lampholders E14 - E27



### 30P - Ghiera in termoplastico Ø 35,5mm - Thermoplastic shade ring Ø 35,5mm

Codice articolo Article code		PCS	CCM cm <sup>3</sup>	Euro Cad.
D/30P/BB	B	1500	21.660	2,20 0,063
D/30P/N	N	1500	21.660	1,90 0,105

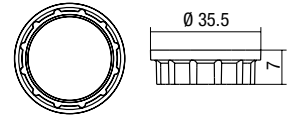

### 31P - Ghiera in termoplastico Ø 43mm - Thermoplastic shade ring Ø 43mm

Codice articolo Article code		PCS	CCM cm <sup>3</sup>	Euro Cad.
D/31P/BB	B	1500	34.656	4,00 0,080
D/31P/N	N	1500	34.656	3,50 0,080

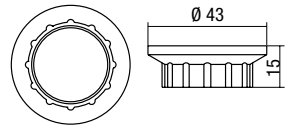

### 71P - Ghiera Ø 48mm - E2 - In termoplastico - Shade ring Ø 48mm - In thermoplastic.

Codice articolo Article code		PCS	CCM cm <sup>3</sup>	Euro Cad.
D/71P/BB	B	1000	21.660	2,80
D/71P/N	N	1000	21.660	2,50

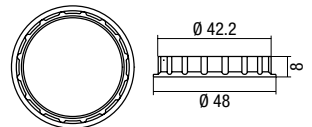

### 73P - Ghiera Ø 58mm - In termoplastico - Shade ring Ø 58mm - In thermoplastic

Codice articolo Article code		PCS	CCM cm <sup>3</sup>	Euro Cad.
D/73P/BB	B	1000	38.988	6,40
D/73P/N	N	1000	38.988	6,30

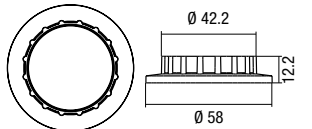

## Portalampada smontati in materiale Termoplastico Unassembled lampholders Thermoplastic material



### 38-PTL

Camicia trasparente E14 corpo liscio in materiale termoplastico  
E14 shirt smooth body in thermoplastic material

Codice articolo Article code		PCS	CCM cm <sup>3</sup>	Euro Cad.
CAM/38/T	T	1000	38.988	9

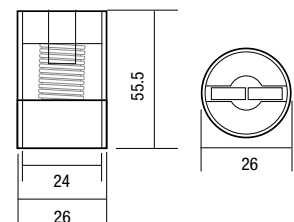

### 38-CAP

Cappello in materiale termoplastico M10x1  
Thermoplastic cap M10x1

Codice articolo Article code		PCS	CCM cm <sup>3</sup>	Euro Cad.
CAP/38/T.IT	T	1000	38.988	3

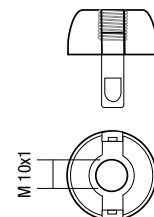

### 38-CAP-NIP

Cappello in materiale termoplastico con nippel in metallo M10x1  
Thermoplastic cap with M10x1 metal nut

Codice articolo Article code		PCS	CCM cm <sup>3</sup>	Euro Cad.
CAP/38/TN.IT	T	1000	38.988	4

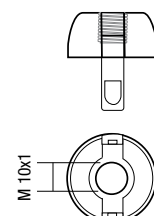

# Interruttori rompifilo unipolari in termoplastico

## Thermoplastic unipolar in line cord-switches



**565** 2[32]A - 250V (2A - 125V - T65) IP40 - PTI250 - 1E4 - Chiusura a scatto - Cavo bipolare o tripolare - Con due morsetti passanti - Approvato JET - IP40 - PTI250 - 1E4  
*lip together case - For two or three core cable - With connection for neutral and for earth - JET approved.*

Codice articolo Article code			PCS	CCM cm <sup>3</sup>	g
BL/565/B	montato/assembled	B	100	8.918	28,00
96-B	montato/assembled	B	100	8.918	28,00
96	montato/assembled	N	100	8.918	28,00
D/565/BB	smontato/not assembled	B	500	64.980	28,00
D/565/N	smontato/not assembled	N	500	64.980	28,00

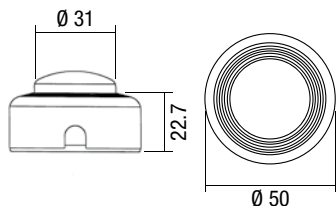

**478** 1[16]A - 250V - T55 (2A - 125V - T85)

IP20 - PTI250 - 1E4 - A bilancere - Contatti in ottone - Morsetti a vite - Chiusura a scatto - Con due morsetti passanti - Approvato UR

*IP20 - PTI250 - 1E4 - Rocker switch - Brass contacts - Screw terminals - Clip together case - With connection for neutral and earth - UR approved*

Codice articolo Article code			PCS	CCM cm <sup>3</sup>	g
92-B	montato/assembled	B	100	5.000	16,00
92	montato/assembled	N	100	5.000	16,00
D/478/BB	smontato/not assembled	B	500	38.988	16,00
D/478/N	smontato/not assembled	N	500	38.988	16,00

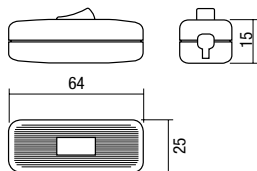

## Cablaggi

### Cordset



**C/63**

Cablaggio con: spina bipolare europea 1063 (2,5A 250V) e cavo piatto 2x0,75mm<sup>2</sup> H03VVH2-F.

*Cordset with: double pole Euro-plug 1063 (2,5A 250V) and flat cable 2x0,75mm<sup>2</sup> H03VVH2-F.*

Codice articolo Article code	L1 m		PCS	CCM cm <sup>3</sup>	g
CB/63/15X22	1,5	B	250	53.235	56,80
CB/63/20X22	2,0	B	250	53.235	79,00
CB/63/30X22	3,0	B	250	53.235	115,00
CN/63/15X22	1,5	N	250	53.235	56,80
CN/63/20X22	2,0	N	250	53.235	79,00
CN/63/30X22	3,0	N	250	53.235	115,00
CII/63/15X22P	1,5	T	250	53.235	56,80
CII/63/20X22P	2,0	T	250	53.235	79,00
CII/63/30X22P	3,0	T	250	53.235	115,00

**Su richiesta:** disponibili lunghezze diverse da quelle riportate a catalogo. Tempo di resa massimo: 5 settimane data ordine  
**On demand:** available different length than what showed into catalogue. Maximum lead time: 5 weeks from order's data





Achille  
Castiglioni

## Interruttori unipolari a pedale Unipolar footswitches



Qualità del progetto a firma di Achille e Piergiacomo Castiglioni  
Quality of project by Achille and Pier Giacomo Castiglioni



U

### 450 - 1[16]A - 250V - T55 - IP40 - PTI250 - 1E4 - Termoplastico - Thermoplastic

A cursore - Contatti in ottone - Morsetti a vite - Chiusura con viti - Per cavo H03VVH2-F - 2x0,75mm<sup>2</sup> - Con morsetto passante

Slide switch - Brass contacts - Screw terminals - Screw closed case - For H03VVH2-F - 2x0,75 mm<sup>2</sup> - Connection for neutral.

Codice articolo Article code		PCS	CCM cm <sup>3</sup>	g
S/450/B	montato/assembled <b>B</b>	100	3.971	8,00
S/450/N	montato/assembled <b>N</b>	100	3.971	8,00

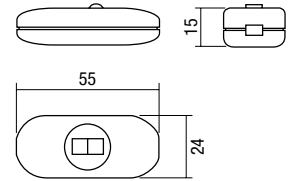

P

### 661 - 2[32]A - 250V - T55 - Bachelite - Bakelite

IP20 - 1E4 - Interruttore con morsetti a vite - Chiusura con viti - Per cavi H03VVH2-F, H03VV-F 2 e 3 x 0,75mm<sup>2</sup> e H05VVH2-F, H05VV-F 2 e 3 x 0,75mm<sup>2</sup> - Con due morsetti passanti.

IP20 - 1E4 - Switch with screw terminals - Screw closed case - For H03VVH2-F, H03VV-F 2 and 3 x 0,75mm<sup>2</sup> and H05VVH2-F, H05VV-F 2 and 3 x 0,75mm<sup>2</sup> cables - With connection for neutral and for earth

Codice articolo Article code		PCS	CCM cm <sup>3</sup>	g
D/661/N	smontato/not assembled <b>N</b>	200	49.096	67,50

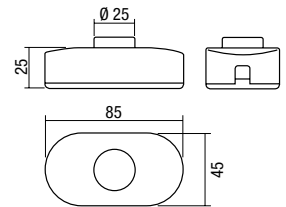

P

### 662 - 2[32]A - 250V - T55 - Bachelite - Bakelite

Tastiera doppia accensione - Chiusura con viti - Con morsetto passante.

Double single pole foot switch - Screw closed case - With connection for neutral.

Codice articolo Article code		PCS	CCM cm <sup>3</sup>	g
D/662/N	smontato/not assembled <b>N</b>	100	38.988	92,00

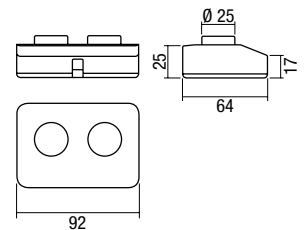

## Interruttori a bilancere - Rocker switches



U

### 144 2[1]A - 250V - T85/55 (2A - 125V - T85)

Contatti in ottone - Morsetti a vite

Brass contact - Screw terminals.

Codice articolo Article code		PCS	CCM cm <sup>3</sup>	g
144/BB	<b>B</b>	3000	30.324	4,50
144/N	<b>N</b>	3000	30.324	4,50

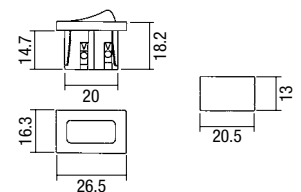

# Interruttori unipolare a pulsante

## Single pole press switches



U

### 135 - 136 1[16]A - 250V - T85/55

Classe II - IP20 - Categoria D - PTI250 - 1E4 - Contatti in ottone - Morsetti a vite - Bottone bianco o nero - Grado inquinamento: normale - Modello /i con ranella.

*Class II - IP20 - Category D - PTI250 - 1E4 - Brass contacts - Screw terminals - Black or white button - Pollution degree: normal - /i model with nut*

Codice articolo Article code		PCS	CCM cm <sup>3</sup>	
135/N	<b>N</b>	3000	21.660	4,10
136/BB	<b>B</b>	3000	30.324	5,00

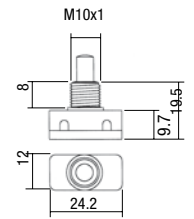

135 - Collo 8mm / Neck 8mm

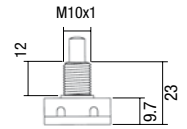

136 - Collo 12mm / Neck 12mm



U

### 115N/T125 1[16]A - 250V - T125/55

Classe II - IP20 - Categoria D - PTI 250 - 1E4 - Contatti in bronzo - Morsetti automatici - Bottone bianco o nero - Grado inquinamento: normale

Modello /i con ranella.

*Class II - IP20 - Category D - PTI 250 - 1E4 - Bronze contacts - Push in terminals - Black or white button - Pollution degree: normal - /i model with nut.*

Codice articolo Article code		PCS	CCM cm <sup>3</sup>	
115N/T125/BB	<b>B</b>	3000	21.660	3,70

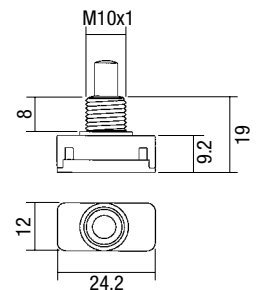

Collo 8mm - Neck 8mm



U

### 63 2[32]A - 250V - T55 (2A - 125V - T65)

Classe II - IP20 - Categoria D - PTI250 - 1E4 - Contatti in lega di ottone - Morsetti a vite - Bottone bianco - Grado inquinamento: normale - Modello /i con ranella.

*Class II - IP20 - Category D - PTI250 - 1E4 - Brass alloy contacts - Screw terminals - White button - Pollution degree: normal - /i model with nut.*

Codice articolo Article code		PCS	CCM cm <sup>3</sup>	
63/BB	<b>B</b>	3000	21.660	3,80

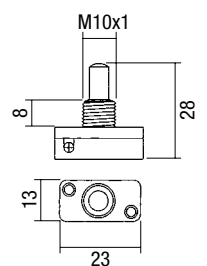

Collo 8mm / Neck 8mm

# Accessori per interruttori a pulsante

## Accessories for press switches

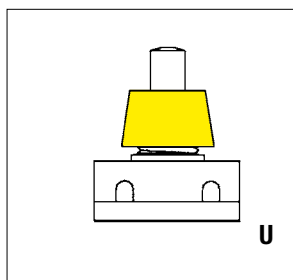

**I**  
Bianco o Nero - Ranella in plastica per articoli 115, 135-136, e 63-63S.  
White or Black - Plastic nut for switches 115, 135-136, and 63-63S.

Codice articolo Article code	PCS	CCM cm <sup>3</sup>	
I/BB <span style="border: 1px solid black; padding: 0 2px;">B</span>	3000	7.546	0,70

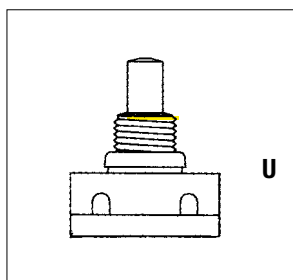
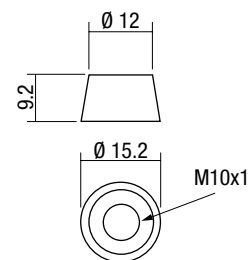

**336**  
Ranella in metallo per articoli 115, 135-136 e 63-63S  
Metal nut for switches 115, 135-136, and 63-63S

Codice articolo Article code	PCS	CCM cm <sup>3</sup>	
336/MT <span style="border: 1px solid black; padding: 0 2px;">C</span>	3000	3.971	0,20

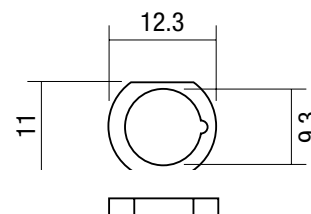

# Interruttori a tirette

## Pull switches



**200**  
**2A dc/ac - 1[16]A - 250V - T125 (2A - 125V - T65)**  
Classe II - Categoria D - PTI250 - 1E4 - Unipolare - Contatti in ottone - Cordicella e pomolino Bianchi 25cm - Grado d'inquinamento: normale  
Class II - IP00 - Category D - PTI250 - 1E4 - Single pole - Brass contacts - 25cm White cord and toggle - Pollution degree: normal.

Codice articolo Article code	PCS	CCM cm <sup>3</sup>	
200/N/B con/with cord. <span style="border: 1px solid black; padding: 0 2px;">N</span>	1000	10.633	6,70
200/S/N senza/without cord. <span style="border: 1px solid black; padding: 0 2px;">N</span>	1000	8.918	6,70
200/328/S/N senza/without cord. * <span style="border: 1px solid black; padding: 0 2px;">N</span>	1000	8.918	6,70

\* con squadretta di fissaggio in metallo + vite - with metal fixing bracket + screw

200/N/B

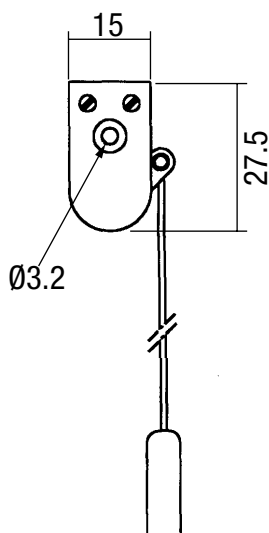

200/S/N

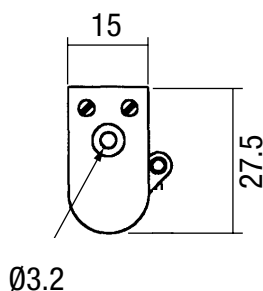

200/238/S/N

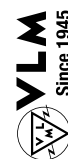
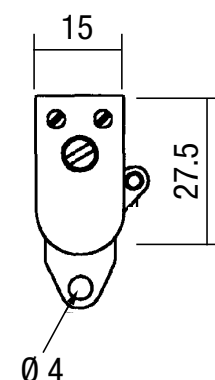

# Termini e condizioni di garanzia - Warranty terms and conditions

La garanzia è applicabile solo quando:

1. I prodotti sono installati, utilizzati e mantenuti in conformità alle specifiche tecniche indicate nella marcatura del prodotto (con riferimento specifico al voltaggio e alla temperatura di funzionamento), alle istruzioni fornite insieme al prodotto e alle norme vigenti.
2. L'installazione e la manutenzione sono eseguite da personale tecnico qualificato.
3. Il difetto segnalato pregiudica il funzionamento del prodotto.
4. Il prodotto non è stato in alcun modo modificato, alterato o trattato con agenti chimici o in qualsiasi altra maniera, senza previa autorizzazione scritta di Relco S.r.l.
5. Il prodotto oggetto della garanzia è messo a disposizione di Relco S.r.l. per ulteriori analisi tecniche e per il tempo necessario al suo svolgimento.
6. Il difetto deve essere denunciato per iscritto a Relco S.r.l. entro 30 (trenta) giorni dalla data del ricevimento dei prodotti (in caso di difetti apparenti) o dalla scoperta del difetto (in caso di difetti occulti).
7. La garanzia ha effetto immediato dalla data di acquisto e farà fede la data della fattura di vendita.
8. Periodi di garanzia superiori a 24 mesi potranno essere richiesti dall'acquirente e verranno accordati dopo aver valutato le condizioni di applicazione specifiche.

Nel caso in cui il difetto venga riconosciuto, Relco S.r.l. sceglierà, a sua discrezione, se riparare o sostituire il prodotto con lo stesso prodotto o con prodotti equivalenti, tenendo in considerazione l'evoluzione tecnica dei prodotti e dei loro componenti.

Qualsiasi intervento tecnico o sostituzione (parziale o completa) del prodotto effettuato in garanzia non darà comunque diritto a prolungamenti o rinnovi della stessa oltre i 5 (cinque) anni dalla data della fornitura, in quanto la relazione legale tra le parti non è rinnovata.

La riparazione o la sostituzione del Prodotto, non include costi o spese per la rimozione o installazione. Relco S.r.l. non rimborserà alcuna perdita consequenziale subita a causa di un prodotto difettoso, come ad esempio costi di spedizione, costi di assemblaggio, costi di installazione in loco, perdita di profitto, costi complessivi degli acquirenti.

## Esclusioni e limitazioni

La presente garanzia non include:

- A. I costi e le spese della manodopera, costi e spese delle attrezzature magazzino e qualsiasi altro costo extra relativo e/o risultante da qualsiasi lavoro necessario per riparare il difetto (es. costi/spese del montaggio e smontaggio, trasporto degli apparecchi difettosi, da riparare e nuovi prodotti) saranno a carico del cliente.
- B. I componenti elettrici soggetti ad usura che sono assimilabili a materiale di consumo (ad esempio, batterie).
- C. I prodotti realizzati su specifica richiesta del cliente e da lui approvati.
- D. Danni al prodotto dovuti a negligenza, al trasporto o ad eventuali imprevisti e di prevedibili situazioni che non rientrino nelle normali condizioni di utilizzo di cui al punto 1 (ad esempio scariche elettriche e fulmini);

La presente garanzia speciale non si applica se l'apparecchio non è usato per lo scopo per cui è stato realizzato;

La presente garanzia non garantisce l'integrità della verniciatura quando il prodotto viene utilizzato in un ambiente salino o in presenza di agenti corrosivi. In nessun caso Relco S.r.l. sarà responsabile per danni accidentali, compensativi, consequenziali, indiretti, speciali o altri danni.

La responsabilità di Relco S.r.l. per un difetto del prodotto sarà in ogni caso limitata alla somma pagata per quel prodotto difettoso.

Il decadimento del flusso è un fenomeno previsto durante la vita del LED e è quindi non protetto da garanzia.

## Controversie Tecniche

In caso di controversia tecnica le parti sottoporranno il prodotto in contestazione a perizia di Esperto Terzo nominato di comune accordo o, in mancanza di accordo, dal Presidente del Tribunale di Milano.

La valutazione dell'esperto sarà vincolante per entrambe le Parti.

Le spese verranno sostenute dalle Parti in misura del 50% ciascuna.

*The conventional warranty applies only when:*

1. *The products are installed, used and maintained in accordance with the technical specifications reported on the product's marking (with specific reference to the operating voltage and temperature), with the instructions provided with the product and with current standards.*
2. *Installation and maintenance are carried out by qualified technical personnel.*
3. *The reported defect affects the operation of the products.*
4. *The product has not been in any way modified, altered or treated with chemicals or in any other way without the prior written consent of Relco S.r.l.*
5. *The product covered by the warranty is made available by Relco S.r.l. for further technical analyses and for the time required to conduct them.*
6. *The defect must be notified in writing to Relco S.r.l. within 30 (thirty) days from the date of receipt of the goods (in case of visible defects) or from the discovery of the defect (in case of hidden defects).*
7. *The warranty has immediate effect from the purchase date, the invoice date serving as proof;*
8. *Warranty periods exceeding 24 months may be requested by the Purchaser and will be agreed after assessing the specific application conditions.*

*In case of the defect is acknowledged by Relco S.r.l., the latter will choose at its discretion whether to repair or replace the product with the same product or with equivalent products, by taking into account the technical evolution of the products and of their components.*

*Any technical intervention or replacement (partial or complete) of the product made during the period covered by the warranty will not provide entitlement to extensions or renewals thereof beyond 5 (five) years from the date of supply, as the legal relationship between the parties has not been renewed.*

*The repair or replacement of the product does not include costs or expenses for removal or reinstallation. Relco S.r.l. shall not be held liable and therefore shall not refund any consequential loss suffered as a result of a defective product, such as costs and shipping, assembly costs, on-site installation costs, loss of profit, the total costs of the buyers.*

## Exclusions and limitations

*This commercial warranty does not include:*

- A. *Costs and expenses for labour, equipment/warehouse costs and expenses and any other extra cost relating to and/or resulting from any work needed to repair the defect (e.g. costs and expenses for assembly/disassembly, transportation of defective appliances to be repaired and new products will be held by the customer);*
- B. *Electrical components subject to wear that are considered wear material (e.g. batteries, etc.)*
- C. *Products manufactured based on specific customer request, and approved by him;*
- D. *Damage to the product due to negligence, transport, unforeseen and unforeseeable events that do not fall under the normal conditions of use of 1 (such as electric shocks and lightning).*

*This special warranty does not apply if the appliance is not used for the purpose it was manufactured for;*

*This warranty does not guarantee the paintwork will remain intact when the product is used in a saline environment or in the presence of corrosive agents. Relco S.r.l. will not, under any circumstances, be responsible for accidental, compensatory, consequential, indirect, special or other kind of damage. The responsibility for Relco S.r.l. for a product defect will be in any case limited to the amount paid for that defective product.*

*The depreciation of the flow is a phenomenon expected during the life of the LED and is therefore not protected by warranty.*

## Technical disputes

*In the event of a technical dispute, the parties will have the product examined by a third-expert appointed by mutual agreement or, if no agreement is reached, by the president of the Court of Milan.*

*The evaluation of the expert will be binding for both parties.*

*Each party will cover 50% of the expenses.*

# Condizioni Generali di vendita - *General sales conditions*



Il presente listino sostituisce ed annulla tutte le precedenti edizioni.

*This price list replaces and cancels all previous editions.*

## Condizioni generali

### **Spedizione Italia:**

**Per poter ottenere il portofranco è necessario effettuare un ordine di almeno Euro 1.500, diversamente il cliente avrà un addebito in fattura del 2.5%.**

**Importo minimo fatturabile Euro 300.**

**La merce sarà evasa nel rispetto della quantità di cubetto o relativi multipli. Per eventuali richieste di disimballo sarà applicato un sovrapprezzo del 10%.**

### **Imballo cartone**

Gratis. La merce viaggia a rischio e pericolo del committente. Trascorsi 8 giorni dal ricevimento merce non si accettano contestazioni.

### **Pagamento**

Per i nuovi clienti ad avviso di merce pronta; per i clienti abituali trascorsi termini di pagamento concordati verranno addebitati gli interessi di mora.

Foro competente Milano.

### **Resi**

Prima di effettuare un reso è necessario richiedere e ottenere, a mezzo mail/fax, l'autorizzazione del nostro ufficio commerciale o del nostro agente di zona per concordarne le modalità. I resi inviati in porto assegnato e/o senza autorizzazione saranno respinti. Le riparazioni/sostituzioni vengono evase non prima di 30 giorni.

Quando il regolatore svolge funzioni vitali nell'impianto sarà necessario prevedere un'adeguata scorta o riserva fredda.

Non si effettuano sostituzioni anticipate.

Nel caso di errori di spedizione o di ordine, il prodotto deve essere reso imballato come all'origine.

### **Assicurazione RCP (responsabilità civile prodotti)**

I prodotti Relco S.r.l. sono marcati e in molti casi Omologati IMQ, VDE, ENEC ecc. per il dettaglio delle omologazioni vedi pagine interne. Tutti i prodotti Relco S.r.l. sono inoltre coperti da una speciale polizza RCP valida in tutto il mondo stipulata con una tra le più prestigiose compagnie di assicurazione.

RELCO S.r.l., persegue una politica di continua ricerca e sviluppo, quindi si riserva di variare in qualsiasi momento e senza preavviso le caratteristiche dei prodotti illustrati. Le informazioni di questo catalogo svolgono un'azione esclusivamente informativa, ed essendo soggette a continue variazioni, non devono essere prese come un impegno da parte di Relco S.r.l.

Relco S.r.l. non si assume alcuna responsabilità per eventuali errori che si possono riscontrare nel presente catalogo. Nessuna parte di questo stampato può essere riprodotto, memorizzato, archiviato o trasmesso in qualsiasi forma o con qualsiasi mezzo elettronico, meccanico o altro, senza previa autorizzazione scritta di Relco S.r.l.

## General conditions

***Ex works minimum invoice charge € 2,500, otherwise the customer will be charged 2.5% on the invoice.***

***Minimum invoice charge 300 euros.***

***The goods will be processed according to cube-based amounts or relative multiples. A 10% charge will be applied on any unpacking requests.***

### Cardboard packaging

*Free. Goods travel at the risk and peril of the client. Complaints must be submitted no later than 8 days after receipt of the goods.*

### Payment

*On being informed that the goods are ready (for new clients); after the agreed deadline for the payment default, interest will be charged (for regular clients). Any disputes shall be settled by the court of Milan.*

### Returns

*Before returning any goods, you need to request and obtain authorisation via email/fax from our sales office or our local representative to agree on how they will be returned. Goods sent on a carriage forward basis and/or without authorisation will be rejected. Repairs/replacements will not be processed for 30 days. Provide for an adequate stock or cold reserve when the dimmer performs essential functions in the system.*

*We do not provide replacements in advance.*

*In case of shipping or order errors, the product must be returned in its original packaging.*

### RCP insurance (civil liability on products)

*Relco S.r.l. products are marked and in many cases type approved IMQ, VDE, ENEC, etc. Please see internal pages for details on type-approval. Moreover, all Relco S.r.l. products are covered by a special RCP insurance policy with one of the top insurance companies, which is valid in any country worldwide.*

***RELCO S.r.l. pursues a policy of continuous research and development and therefore reserves the right to change the characteristics of the products without prior warning. The information in this catalogue is only meant for informative purposes and is subject to constant changes, which means that it must not be considered as a commitment on behalf of Relco S.r.l.***

***Relco S.r.l. shall not be liable for any errors reported in this catalogue. No part of this publication can be reproduced, saved, filed or transmitted under any form and by any electronic, mechanical or any other kind of means without the prior permission in writing of Relco S.r.l.***